

DCR-TRV738E/TRV740/ TRV740E/TRV840

RMT-814

SERVICE MANUAL

LEVEL 2

Ver 1.0 2002.03

Revision History



Photo : DCR-TRV740E

US Model
Canadian Model
DCR-TRV740/TRV840
AEP Model
DCR-TRV738E/TRV740E
Australian Model
Hong Kong Model
Chinese Model
East European Model
North European Model
Russian Model
DCR-TRV740E
E Model
DCR-TRV740/TRV740E/TRV840
Korea Model
DCR-TRV740
Tourist Model
DCR-TRV740/TRV740E
Argentina Model
DCR-TRV840

M2000 MECHANISM

Link

SPECIFICATIONS	BLOCK DIAGRAMS	PRINTED WIRING BOARDS
SERVICE NOTE	FRAME SCHEMATIC DIAGRAMS	ADJUSTMENTS
DISASSEMBLY	SCHEMATIC DIAGRAMS	REPAIR PARTS LIST

- For INSTRUCTION MANUAL, refer to separate file (992993871.pdf).
- For MECHANISM ADJUSTMENTS, refer to the "8mm Video MECHANICAL ADJUSTMENT MANUAL IX [M2000 MECHANISM]" (9-929-861-11).
- The DCR-TRV740E uses two types of 2.5 inch LCD. For identification of the 2.5 inch LCD, see "SECTION 5. 1-5-1. LCD Type Check".
- The DCR-TRV840 uses two types of the type SO or type CA LCD. For identification of the type SO or type CA LCD, see "SECTION 5. 1-5-1. LCD Type Check".

On the VC-278 board

This service manual provides the information that is premised the circuit board replacement service and not intended repair inside the VC-278 board.

Therefore, schematic diagram, printed wiring board, waveforms, mounted parts location and electrical parts list of the VC-278 board are not shown.

The following pages are not shown.

Schematic diagram	Pages 4-23 to 4-72	Mounted parts location	Pages 4-97 to 4-98
Printed wiring board	Pages 4-87 to 4-90	Electrical parts list	Pages 6-17 to 6-25
Waveforms	Pages 4-93 to 4-95		

 **DIGITAL VIDEO CAMERA RECORDER**

SONY®



SPECIFICATIONS

Video camera recorder

System

Video recording system
2 rotary heads
Helical scanning system
Audio recording system
Rotary heads, PCM system
Quantization: 12 bits (Fs 32 kHz, stereo 1, stereo 2), 16 bits (Fs 48 kHz, stereo)
Video signal
DCR-TRV740/TRV840:
NTSC color, EIA standards
DCR-TRV738E/TRV740E:
PAL colour, CCIR standards
Recommended cassette
Hi8/Digital8 video cassette
Recording/playback time
DCR-TRV740/TRV840:
(using 120 min. Hi8 video cassette)
DCR-TRV738E/TRV740E:
(using 90 min. Hi8 video cassette)
SP mode: 1 hour
LP mode: 1 hour and 30 minutes
Fast-forward/rewind time
DCR-TRV740/TRV840:
(using 120 min. Hi8 video cassette)
DCR-TRV738E/TRV740E:
(using 90 min. Hi8 video cassette)
Approx. 5 min.
Viewfinder
Electric Viewfinder, Monochrome
Image device
DCR-TRV740/TRV840:
4.5 mm (1/4 type) CCD
(Charge Coupled Device)
Gross: Approx. 1 070 000 pixels
Effective: Approx. 690 000 pixels
(Camera mode)
Approx. 1 000 000 pixels
(Memory mode)
DCR-TRV738E:
3.8 mm (1/4.7 type) CCD
(Charge Coupled Device)
Gross: Approx. 1 070 000 pixels
Effective: Approx. 690 000 pixels
(Camera mode)
Approx. 1 000 000 pixels
(Memory mode)
DCR-TRV740E:
3.8 mm (1/4.7 type) CCD
(Charge Coupled Device)
Gross: Approx. 1 070 000 pixels
Effective (still):
Approx. 1 000 000 pixels
Effective (moving):
Approx. 690 000 pixels
Lens
Combined power zoom lens
Filter diameter 37 mm (1 1/2 in.)
15× (Optical), 420× (Digital)
Focal length
3.6 - 54 mm (5/32 - 2 1/4 in.)
When converted to a 35 mm still camera
Camera mode:
48 - 720 mm (1 15/16 - 28 3/8 in.)

Memory mode:
40 - 600 mm (1 5/8 - 23 5/8 in.)
Color temperature
Auto
Minimum illumination
7 lx (lux) (F1.6)
0 lx (lux) (in the NightShot mode)*
* Objects unable to be seen due to the dark can be shot with infrared lighting.

Input/output connectors

DCR-TRV738E:
S video output
DCR-TRV740/TRV740E/TRV840:
S video input/output
4-pin mini DIN
Luminance signal: 1 Vp-p, 75 Ω (ohms), unbalanced
DCR-TRV740/TRV840:
Chrominance signal: 0.286 Vp-p, 75 Ω (ohms), unbalanced
DCR-TRV738E/TRV740E:
Chrominance signal: 0.3 Vp-p, 75 Ω (ohms), unbalanced
DCR-TRV738E:
Audio/Video output
DCR-TRV740/TRV740E/TRV840:
Audio/Video input/output
AV MINIJACK, 1 Vp-p, 75 Ω (ohms), unbalanced, sync negative 327 mV, (at output impedance more than 47 kΩ (kilohms))
Output impedance with less than 2.2 kΩ (kilohms)/Stereo minijack (ø 3.5 mm)
DCR-TRV740/TRV740E/TRV840:
Input impedance more than 47 kΩ (kilohms)
Headphone jack
Stereo minijack (ø 3.5 mm)
USB jack
mini-B
LANC jack
Stereo mini-minijack (ø 2.5 mm)
MIC jack
Stereo minijack (ø 3.5 mm)
DCR-TRV738E:
DV output
DCR-TRV740/TRV740E/TRV840:
DV input/output
4-pin connector

LCD screen

Picture
DCR-TRV738E/TRV740/TRV740E:
6.2 cm (2.5 type)
50.3 × 37.4 mm (2 × 1 1/2 in.)
DCR-TRV840:
8.8 cm (3.5 type)
72.2 × 50.4 mm (2 7/8 × 2 in.)
Total dot number
For NTSC models and European models:
123 200 (560 × 220)
For other countries models of
DCR-TRV740E:
61 600 (280 × 220)

General

Power requirements
7.2 V (battery pack)
8.4 V (AC power adaptor)
Average power consumption (when using the battery pack)
During camera recording using LCD
DCR-TRV738E:
3.4 W
DCR-TRV740:
4.3 W
DCR-TRV740E:
4.2 W
DCR-TRV840:
4.5 W
Viewfinder
DCR-TRV740/TRV840:
3.5 W
DCR-TRV738E/TRV740E:
3.4 W
Operating temperature
0°C to 40°C (32°F to 104°F)
Recommended charging temperature
10°C to 30°C (50°F to 86°F)
Storage temperature
-20°C to +60°C (-4°F to +140°F)
Dimensions (approx.)
207 × 101 × 85 mm
(8 1/4 × 4 × 3 3/8 in.)
Mass (approx.)
DCR-TRV738E/TRV740/TRV740E:
900 g (1 lb 15 oz)
DCR-TRV840:
930 g (2 lb)
excluding the battery pack, cassette, lens cap and shoulder strap
DCR-TRV738E/TRV740/TRV740E:
1 040 g (2 lb 4 oz)
DCR-TRV840:
1 070 g (2 lb 5 oz)
including the battery pack (NP-FM50), 120min. Hi8 cassette (DCR-TRV740/TRV840), 90min. Hi8 cassette (DCR-TRV738E/TRV740E), lens cap and shoulder strap
Supplied accessories
See page 4.

AC power adaptor

Power requirements
100 - 240 V AC, 50/60 Hz
Power consumption
23 W
Output voltage
DC OUT: 8.4 V, 1.5 A in the operating mode
Operating temperature
0°C to 40°C (32°F to 104°F)
Storage temperature
-20°C to +60°C (-4°F to +140°F)
Dimensions (approx.)
125 × 39 × 62 mm
(5 × 1 9/16 × 2 1/2 in.) (w/h/d)
excluding projecting parts
Mass (approx.)
280 g (9.8 oz)
excluding power cord

Battery pack

Maximum output voltage
DC 8.4 V
Mean output voltage
DC 7.2 V
Capacity
8.5 wh (1 180 mAh)
Operating temperature
0°C to 40°C (32°F to 104°F)
Dimensions (approx.)
38.2 × 20.5 × 55.6 mm
(1 9/16 × 13/16 × 2 1/4 in.) (w/h/d)
Mass (approx.)
76 g (2.7 oz)
Type
Lithium ion

"Memory Stick"

Memory
Flash memory
8MB: MSA-8A
Operating voltage
2.7 - 3.6 V
Power consumption
Approx. 45 mA in the operating mode
Approx. 130 μA in the standby mode
Dimensions (approx.)
50 × 2.8 × 21.5 mm
(2 × 1/8 × 7/8 in.) (w/h/d)
Mass (approx.)
4 g (0.14 oz)

Design and specifications are subject to change without notice.

SAFETY-RELATED COMPONENT WARNING!!

COMPONENTS IDENTIFIED BY MARK \triangle OR DOTTED LINE WITH MARK \triangle ON THE SCHEMATIC DIAGRAMS AND IN THE PARTS LIST ARE CRITICAL TO SAFE OPERATION. REPLACE THESE COMPONENTS WITH SONY PARTS WHOSE PART NUMBERS APPEAR AS SHOWN IN THIS MANUAL OR IN SUPPLEMENTS PUBLISHED BY SONY.

ATTENTION AU COMPOSANT AYANT RAPPORT À LA SÉCURITÉ!

LES COMPOSANTS IDENTIFIÉS PAR UNE MARQUE \triangle SUR LES DIAGRAMMES SCHÉMATIQUES ET LA LISTE DES PIÈCES SONT CRITIQUES POUR LA SÉCURITÉ DE FONCTIONNEMENT. NE REMPLACER CES COMPOSANTS QUE PAR DES PIÈCES SONY DONT LES NUMÉROS SONT DONNÉS DANS CE MANUEL OU DANS LES SUPPLÉMENTS PUBLIÉS PAR SONY.

CAUTION :

Danger of explosion if battery is incorrectly replaced.
Replace only with the same or equivalent type.

SAFETY CHECK-OUT

After correcting the original service problem, perform the following safety checks before releasing the set to the customer.

1. Check the area of your repair for unsoldered or poorly-soldered connections. Check the entire board surface for solder splashes and bridges.
2. Check the interboard wiring to ensure that no wires are "pinched" or contact high-wattage resistors.
3. Look for unauthorized replacement parts, particularly transistors, that were installed during a previous repair. Point them out to the customer and recommend their replacement.
4. Look for parts which, through functioning, show obvious signs of deterioration. Point them out to the customer and recommend their replacement.
5. Check the B+ voltage to see it is at the values specified.
6. Flexible Circuit Board Repairing
 - Keep the temperature of the soldering iron around 270°C during repairing.
 - Do not touch the soldering iron on the same conductor of the circuit board (within 3 times).
 - Be careful not to apply force on the conductor when soldering or unsoldering.

Unleaded solder

Boards requiring use of unleaded solder are printed with the lead-free mark (LF) indicating the solder contains no lead.

(Caution: Some printed circuit boards may not come printed with the lead free mark due to their particular size.)

**: LEAD FREE MARK**

Unleaded solder has the following characteristics.

- Unleaded solder melts at a temperature about 40°C higher than ordinary solder.
Ordinary soldering irons can be used but the iron tip has to be applied to the solder joint for a slightly longer time.
Soldering irons using a temperature regulator should be set to about 350°C.
Caution: The printed pattern (copper foil) may peel away if the heated tip is applied for too long, so be careful!
- Strong viscosity
Unleaded solder is more viscous (sticky, less prone to flow) than ordinary solder so use caution not to let solder bridges occur such as on IC pins, etc.
- Usable with ordinary solder
It is best to use only unleaded solder but unleaded solder may also be added to ordinary solder.

DCR-TRV738E/TRV740/TRV740E/TRV840

• SUPPLIED ACCESSORIES

Make sure that the following accessories are supplied with your camcorder.

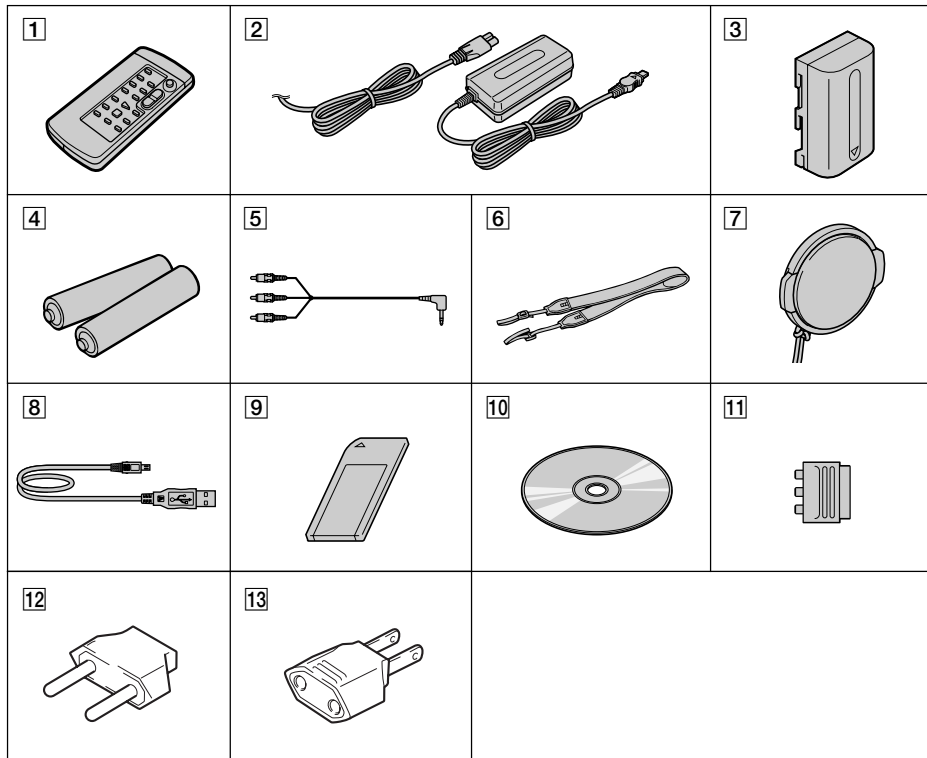

- | | |
|--------------------------------------------------------------------------------------------------------------------------------------------------------------------------------------------------------------------------------------------------------------------------------------------------------------------------------------------------------------------------|---------------------------------------------------------------------------------------------------------------------------------------------------------------------------------------------------------------------------------------------------------------------------------------------------------------------------------------------------------------------------------------------------------------|
| <p>1 Wireless Remote Commander (1)</p> <p>2 AC-L10A/L10B/L10C AC power adaptor (1), Power cord (1)</p> <p>3 NP-FM50 battery pack (1)</p> <p>4 Size AA (R6) battery for Remote Commander (2)</p> <p>5 A/V connecting cable (1.5m)(1)</p> <p>6 Shoulder strap (1)</p> <p>7 Lens cap (1)</p> <p>8 USB cable (1)</p> | <p>9 "Memory Stick" (1)</p> <p>10 CD-ROM (USB Driver) (1)
SPVD (I) : US, CND models
SPVD : For other models</p> <p>11 21-pin adaptor (1)
For European models only</p> <p>12 2-pin conversion adaptor (1)
DCR-TRV740: JE model/
DCR-TRV740E: JE model only</p> <p>13 2-pin conversion adaptor (1)
DCR-TRV740: E/
TRV740E: E, HK models only</p> |
|--------------------------------------------------------------------------------------------------------------------------------------------------------------------------------------------------------------------------------------------------------------------------------------------------------------------------------------------------------------------------|---------------------------------------------------------------------------------------------------------------------------------------------------------------------------------------------------------------------------------------------------------------------------------------------------------------------------------------------------------------------------------------------------------------|

Table for difference of function

Model	DCR-TRV738E	DCR-TRV740	DCR-TRV740E		DCR-TRV840	Remark
Destination	AEP	US, CND, E, KR, JE	AEP, EE, NE, RU	E, AUS, HK, JE, CH	US, CND, E, AR	
Color System	PAL	NTSC	PAL		NTSC	
LCD	size	2.5 inch			3.5 inch	
	pixel	123k	61k	123k	61k	123k
	type	SH	SO	SH	SO	SO or CA
VTR REC	×	○				○ : with REC button

• Abbreviation

- CND : Canadian model
- KR : Korea model
- JE : Tourist model
- AUS : Australian model
- HK : Hong Kong model
- CH : Chinese model
- EE : East European model
- NE : North European model
- RU : Russian model
- AR : Argentina model

- The DCR-TRV740E uses two types of 2.5 inch LCD. For identification of the 2.5 inch LCD, see "SECTION 5. 1-5-1. LCD Type Check".
- The DCR-TRV840 uses two types of the type SO or type CA LCD. For identification of the type SO or type CA LCD, see "SECTION 5. 1-5-1. LCD Type Check".

TABLE OF CONTENTS

1. SERVICE NOTE

1-1. SERVICE NOTE	1-1
1. POWER SUPPLY DURING REPAIRS	1-1
2. TO TAKE OUT A CASSETTE WHEN NOT EJECT (FORCE EJECT)	1-1
1-2. SELF-DIAGNOSIS FUNCTION	1-2
1. Self-diagnosis Function	1-2
2. Self-diagnosis Display	1-2
3. Service Mode Display	1-2
3-1. Display Method	1-2
3-2. Switching of Backup No.	1-2
3-3. End of Display	1-2
4. Self-diagnosis Code Table	1-3

2. DISASSEMBLY

2-1. 2.5 INCH LCD UNIT, PD-156/160 BOARD -1	2-2
2-2. 2.5 INCH LCD UNIT, PD-156/160 BOARD -2	2-3
2-3. 3.5 INCH LCD UNIT, PD-156/160 BOARD -1	2-4
2-4. 3.5 INCH LCD UNIT, PD-156/160 BOARD -2	2-4
2-5. BACK LIGHT	2-5
2-6. FRONT PANEL SECTION	2-6
2-7. SI-032 BOARD	2-6
2-8. MICROPHONE	2-7
2-9. CABINET (R) SECTION	2-8
2-10. LENS SECTION	2-9
2-11. CD-358 BOARD	2-9
2-12. IRIS FLEXIBLE ASSEMBLY	2-10
2-13. EVF SECTION	2-11
2-14. LB-076 BOARD -1	2-11
2-15. LB-076 BOARD -2	2-12
2-16. BATTERY PANEL SECTION	2-13
2-17. BATTERY TERMINAL BOARD	2-13
2-18. MEMORY STICK 10P CONNECTOR	2-14
2-19. CONTROL SWITCH BLOCK (SS-1380)	2-14
2-20. CABINET (L) SECTION	2-15
2-21. CS FRAME ASSEMBLY (25)	2-15
2-22. VC-278 BOARD	2-16
2-23. MECHANISM DECK	2-16
2-24. CONTROL SWITCH BLOCK (CF-2500)	2-19
2-25. CONTROL SWITCH BLOCK (FK-2500)	2-19
2-26. HINGE SECTION	2-20
2-27. CIRCUIT BOARDS LOCATION	2-21
2-28. FLEXIBLE BOARDS LOCATION	2-22

3. BLOCK DIAGRAMS

3-1. OVERALL BLOCK DIAGRAM (1/6)	3-1
3-2. OVERALL BLOCK DIAGRAM (2/6)	3-3
3-3. OVERALL BLOCK DIAGRAM (3/6)	3-5
3-4. OVERALL BLOCK DIAGRAM (4/6)	3-7
3-5. OVERALL BLOCK DIAGRAM (5/6)	3-9
3-6. OVERALL BLOCK DIAGRAM (6/6)	3-11
3-7. POWER BLOCK DIAGRAM (1/3)	3-13
3-8. POWER BLOCK DIAGRAM (2/3)	3-15
3-9. POWER BLOCK DIAGRAM (3/3)	3-17

4. PRINTED WIRING BOARDS AND SCHEMATIC DIAGRAMS

4-1. FRAME SCHEMATIC DIAGRAM (1/2)	4-1
FRAME SCHEMATIC DIAGRAM (2/2)	4-3
4-2. SCHEMATIC DIAGRAMS	
• CD-358 (CCD IMAGER) SCHEMATIC DIAGRAM	4-7
• LB-076 (EVF, BACK LIGHT) SCHEMATIC DIAGRAM	4-8
• SI-032 (STEADY SHOT, LASER LINK), FP-411 FLEXIBLE SCHEMATIC DIAGRAM	4-9

• CONTROL SWITCH BLOCK (CF-2500) SCHEMATIC DIAGRAM	4-11
• PD-156 (1/2)(LCD DRIVER, BACKLIGHT) SCHEMATIC DIAGRAM	4-13
• PD-156 (2/2)(DRIVER, TIMING GENERATOR) SCHEMATIC DIAGRAM	4-15
• PD-160 (1/2)(CHA, DISPLAY DRIVE, BACK LIGHT) SCHEMATIC DIAGRAM	4-17
• PD-160 (2/2)(LCD DRIVE, TG) SCHEMATIC DIAGRAM	4-19
• LS-057 (S/T REEL SENSOR), FP-228 (DEW SENSOR), FP-299 (MODE SWITCH), FP-300 (TAPE TOP), FP-302 (TAPE END), FP-301 (TAPE LED) FLEXIBLE SCHEMATIC DIAGRAMS	4-21
• FP-410 FLEXIBLE, CONTROL SWITCH BLOCK (SS-1380) SCHEMATIC DIAGRAM	4-21

Schematic diagram of the VC-278 board are not shown.
Pages from 4-23 to 4-72 are not shown.

4-3. PRINTED WIRING BOARDS

• CD-358 (CCD IMAGER) PRINTED WIRING BOARD	4-73
• LB-076 (EVF, BACK LIGHT) PRINTED WIRING BOARD	4-74
• SI-032 (STEADY SHOT, LASER LINK) PRINTED WIRING BOARD	4-75
• FP-411 FLEXIBLE BOARD	4-76
• LS-057 (S/T REEL SENSOR), FP-228 (DEW SENSOR), FP-299 (MODE SWITCH), FP-300 (TAPE TOP), FP-302 (TAPE END), FP-301 (TAPE LED) FLEXIBLE BOARDS	4-77
• FP-410 FLEXIBLE BOARD	4-78
• PD-156 (LCD DRIVER, BACKLIGHT, DRIVER, TIMING GENERATOR) PRINTED WIRING BOARD	4-79
• PD-160 (CHA, DISPLAY DRIVE, BACK LIGHT, LCD DRIVE, TG) PRINTED WIRING BOARD	4-83
• FP-412 FLEXIBLE BOARD	4-86

Printed wiring board of the VC-278 board are not shown.
Pages from 4-87 to 4-90 are not shown.

4-4. WAVEFORMS 4-91

Waveforms of the VC-278 board are not shown.
Pages from 4-93 to 4-95 are not shown.

4-5. MOUNTED PARTS LOCATION 4-96

Mounted parts location of the VC-278 board is not shown.
Pages from 4-97 to 4-98 are not shown.

5. ADJUSTMENTS

1. Adjusting items when replacing main parts and boards ..	5-2
5-1. CAMERA SECTION ADJUSTMENT	5-4
1-1. PREPARATIONS BEFORE ADJUSTMENT (CAMERA SECTION)	5-4
1-1-1. List of Service Tools	5-4
1-1-2. Preparations	5-5
1-1-3. Precaution	5-7
1. Setting the Switch	5-7
2. Order of Adjustments	5-7

3. Subjects	5-7	2-1. Hi8/STANDARD 8 MODE	5-40
1-2. INITIALIZATION OF 8, A, B, C, D, E, F, 1B, 1C, 1E, 1F PAGE DATA	5-8	2-1-1. OPERATING WITHOUT CASSETTE	5-40
1-2-1. INITIALIZATION OF A, D PAGE DATA	5-9	2-1-2. TAPE PATH ADJUSTMENT	5-40
1. Initializing the A, D Page Data	5-9	1. Preparations for Adjustment	5-40
2. Modification of A, D Page Data	5-9	2-2. DIGITAL8 MODE	5-41
3. A Page Table	5-9	2-2-1. HOW TO ENTER RECORD MODE WITHOUT CASSETTE	5-41
4. D Page Table	5-10	2-2-2. HOW TO ENTER PLAYBACK MODE WITHOUT CASSETTE	5-41
1-2-2. INITIALIZATION OF B, 1B PAGE DATA	5-11	2-2-3. OVERALL TAPE PATH CHECK	5-41
1. Initializing the B, 1B Page Data	5-11	1. Recording of the tape path check signal	5-41
2. Modification of B, 1B Page Data	5-11	2. Tape path check	5-41
3. Loader writing inhibit mode setting	5-11	5-3. VIDEO SECTION ADJUSTMENT	5-42
4. B Page Table	5-11	3-1. PREPARATIONS BEFORE ADJUSTMENTS	5-42
5. 1B Page Table	5-11	3-1-1. Equipment to Required	5-42
1-2-3. INITIALIZATION OF 8, C, 1C PAGE DATA	5-12	3-1-2. Precautions on Adjusting	5-43
1. Initializing the 8, C, 1C Page Data	5-12	3-1-3. Adjusting Connectors	5-44
2. Modification of 8, C, 1C Page Data	5-12	3-1-4. Connecting the Equipment	5-44
3. 8 Page Table	5-13	3-1-5. Alignment Tape	5-45
4. C Page Table	5-13	3-1-6. Input/output Level and Impedance	5-46
5. 1C Page Table	5-15	3-2. SYSTEM CONTROL SYSTEM ADJUSTMENT	5-47
1-2-4. INITIALIZATION OF E, F, 1E, 1F PAGE DATA	5-16	1. Initialization of 8, A, B, C, D, E, F, 1B, 1C, 1E, 1F Page Data	5-47
1. Initializing the E, F, 1E, 1F Page Data	5-16	2. Serial No. Input	5-47
2. Modification of E, F, 1E, 1F Page Data	5-16	2-1. Company ID Input	5-47
3. E Page Table	5-17	2-2. Serial No. Input	5-47
4. F Page Table	5-18	3-3. SERVO AND RF SYSTEM ADJUSTMENT	5-49
5. 1E Page Table	5-19	1. REEL FG Adjustment (VC-278 board)	5-49
6. 1F Page Table	5-19	2. PLL f_0 & LPF f_0 Adjustment (VC-278 board)	5-49
1-3. CAMERA SYSTEM ADJUSTMENTS	5-20	3. Switching Position Adjustment (VC-278 board)	5-50
1. HALL Adjustment	5-20	4. AGC Center Level and APC & AEQ Adjustment	5-50
2. Flange Back Adjustment (Using Minipattern Box)	5-21	4-1. Preparations before adjustments	5-50
3. Flange Back Adjustment (Using Flange Back Adjustment Chart and Subject More Than 500m Away)	5-22	4-2. AGC Center Level Adjustment (VC-278 board)	5-50
3-1. Flange Back Adjustment (1)	5-22	4-3. APC & AEQ Adjustment (VC-278 board)	5-51
3-2. Flange Back Adjustment (2)	5-22	4-4. Processing after Completing Adjustments	5-51
4. Flange Back Check	5-23	5. PLL f_0 & LPF f_0 Fine Adjustment (VC-278 board)	5-52
5. Mechanical Shutter Adjustment	5-23	6. Hi8/Standard8 Switching Position Adjustment (VC-278 board)	5-52
6. Black Defective CCD Adjustment	5-24	7. CAP FG Duty Adjustment (VC-278 board)	5-53
7. Picture Frame Setting	5-24	3-4. VIDEO SYSTEM ADJUSTMENTS	5-54
8. Color Reproduction Adjustment	5-25	1. 54MHz/66MHz Origin Oscillation Adjustment (VC-278 board)	5-54
9. Auto White Balance & LV Standard Data Input	5-26	2. S VIDEO OUT Y Level Adjustment (VC-278 board)	5-54
10. Auto White Balance Adjustment	5-27	3. S VIDEO OUT Chroma Level Adjustment (VC-278 board)	5-55
11. White Balance Check	5-28	4. VIDEO OUT Y, Chroma Level Check (VC-278 board)	5-55
12. Steady Shot Check	5-29	5. Hi8/Standard8 Y/C Output Level Setting (VC-278 board)	5-56
1-4. ELECTRONIC VIEWFINDER SYSTEM ADJUSTMENT	5-30	6. Hi8/standard 8mm AFC f_0 Adjustment (VC-278 board)	5-56
1. VCO Adjustment (VC-278 board)	5-30	3-5. AUDIO SYSTEM ADJUSTMENTS	5-57
2. RGB AMP Adjustment (VC-278 board)	5-31	1. Hi8/Standard8 AFM BPF f_0 Adjustment (VC-278 board)	5-57
3. Contrast Adjustment (VC-278 board)	5-31	2. Hi8/Standard8 AFM 1.5 MHz Deviation Adjustment (VC-278 board)	5-58
1-5. LCD SYSTEM ADJUSTMENT	5-32	3. Hi8/Standard8 AFM 1.7 MHz Deviation Adjustment (VC-278 board)	5-58
1-5-1. LCD Type Check	5-32	4. Digital8 Playback Level Check	5-58
1-5-2. LCD SYSTEM ADJUSTMENT (PD-156 board)	5-33	5. Overall Level Characteristics Check	5-58
1. VCO Adjustment (PD-156 board)	5-33	6. Overall Distortion Check	5-58
2. RGB AMP Adjustment (PD-156 board)	5-33	7. Overall Noise Level Check	5-59
3. Contrast Adjustment (PD-156 board)	5-34	8. Overall Separation Check	5-59
4. COM AMP Adjustment (PD-156 board)	5-34	5-4. SERVICE MODE	5-60
5. V-COM Adjustment (PD-156 board)	5-35	4-1. ADJUSTMENT REMOTE COMMANDER	5-60
6. White Balance Adjustment (PD-156 board)	5-35	1. Using the Adjustment Remote Commander	5-60
1-5-3. LCD SYSTEM ADJUSTMENT (PD-160 board)	5-36	2. Precautions Upon Using the Adjustment Remote Commander	5-60
1. VCO Adjustment (PD-160 board)	5-36	4-2. DATA PROCESS	5-61
2. PSIG Gray Adjustment (PD-160 board)	5-36	4-3. SERVICE MODE	5-62
3. RGB AMP Adjustment (PD-160 board)	5-37		
4. Black Limit Adjustment (PD-160 board)	5-37		
5. Contrast Adjustment (PD-160 board)	5-38		
6. Center Level Adjustment (PD-160 board)	5-38		
7. V-COM Adjustment (PD-160 board)	5-39		
8. White Balance Adjustment (PD-160 board)	5-39		
5-2. MECHANISM SECTION ADJUSTMENT	5-40		

1.	Setting the Test Mode	5-62
2.	Emergency Memory Address	5-62
2-1.	EMG Code (Emergency Code)	5-62
2-2.	MSW Code	5-63
3.	Bit Value Discrimination	5-64
4.	Switch check (1)	5-64
5.	Switch check (2)	5-64
6.	Switch check (3)	5-65
7.	Switch check (4)	5-65
8.	Record of Use check (1)	5-65
9.	Record of Use check (2)	5-66
10.	Record of Self-diagnosis check	5-66

6. REPAIR PARTS LIST

6-1.	EXPLODED VIEWS	6-1
6-1-1.	OVERALL SECTION	6-1
6-1-2.	CABINET (L) SECTION-1	6-2
6-1-3.	CABINET (L) SECTION-2	6-3
6-1-4.	LENS, EVF SECTION	6-4
6-1-5.	CABINET (R) SECTION	6-5
6-1-6.	LCD SECTION (2.5 INCH LCD MODEL) (TRV738E/TRV740/TRV740E)	6-6
6-1-7.	LCD SECTION (3.5 INCH LCD MODEL) (TRV840) ..	6-7
6-1-8.	CASSETTE COMPARTMENT ASSY, DRUM ASSY ...	6-8
6-1-9.	LS CHASSIS BLOCK ASSEMBLY	6-9
6-1-10.	MECHANICAL CHASSIS BLOCK ASSEMBLY-1 ..	6-10
6-1-11.	MECHANICAL CHASSIS BLOCK ASSEMBLY-2 ..	6-11
6-2.	ELECTRICAL PARTS LIST	6-12

Parts list of the VC-278 board are not shown.
Pages from 6-17 to 6-25 are not shown.

* Color reproduction frame are shown on page 181.



SECTION 1 SERVICE NOTE

1-1. SERVICE NOTE

1. POWER SUPPLY DURING REPAIRS

In this unit, about 10 seconds after power is supplied (8.4V) to the battery terminal using the service power code (J-6082-223-A), the power is shut off so that the unit cannot operate.

These following two methods are available to prevent this. Take note of which to use during repairs.

Method 1.

Use the DC IN terminal. (Use the AC power adaptor.)

Method 2.

Connect the adjustment remote commander RM-95 (J-6082-053-B) to the LANC jack, and set the HOLD switch to the "ADJ" side.

2. TO TAKE OUT A CASSETTE WHEN NOT EJECT (FORCE EJECT)

- ① Refer to 2-6. to remove the front panel section.
- ② Refer to 2-9. to remove the cabinet (upper) section.
- ③ Refer to 2-9. to remove the cabinet (R) section.
- ④ Refer to 2-10. to remove the lens section.
- ⑤ Refer to 2-13. to remove the EVF section.
- ⑥ Refer to 2-16. to remove the battery panel section.
- ⑦ Refer to 2-19. and 2-21. to remove the cabinet (L) section. (Include the CS frame assembly and control switch block (SS-1380).)
- ⑧ Disconnect CN4401 (2P) of VC-278 board.
- ⑨ Add +5V from the DC POWER SUPPLY and unload with a pressing the cassette compartment.

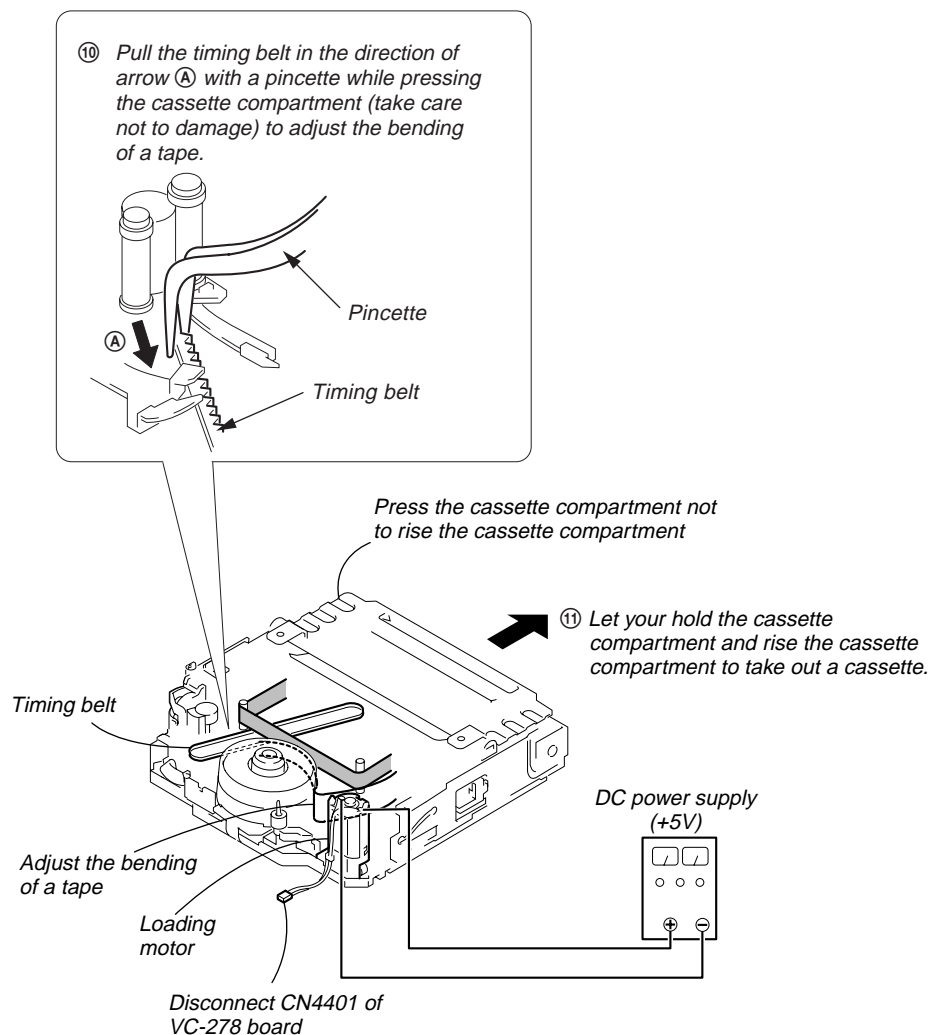

1-2. SELF-DIAGNOSIS FUNCTION

1. Self-diagnosis Function

When problems occur while the unit is operating, the self-diagnosis function starts working, and displays on the viewfinder or Display window what to do. This function consists of two display; self-diagnosis display and service mode display.

Details of the self-diagnosis functions are provided in the Instruction manual.

2. Self-diagnosis Display

When problems occur while the unit is operating, the counter of the viewfinder or Display window shows a 4-digit display consisting of an alphabet and numbers, which blinks at 3.2 Hz. This 5-character display indicates the “repaired by:”, “block” in which the problem occurred, and “detailed code” of the problem.

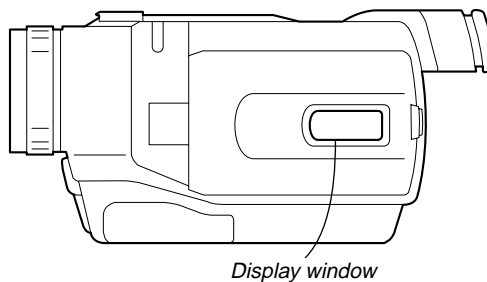
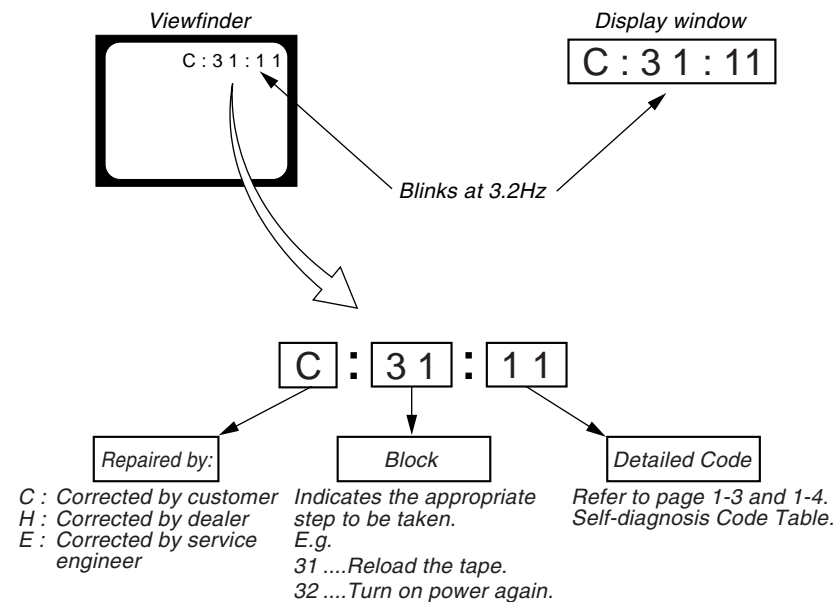

3. Service Mode Display

The service mode display shows up to six self-diagnosis codes shown in the past.

3-1. Display Method

While pressing the “STOP” key, set the switch from OFF to “VTR or PLAYER”, and continue pressing the “STOP” key for 5 seconds continuously. The service mode will be displayed, and the counter will show the backup No. and the 5-character self-diagnosis codes.

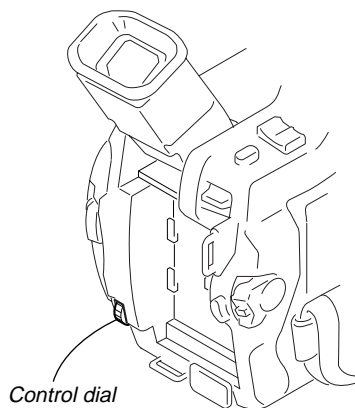
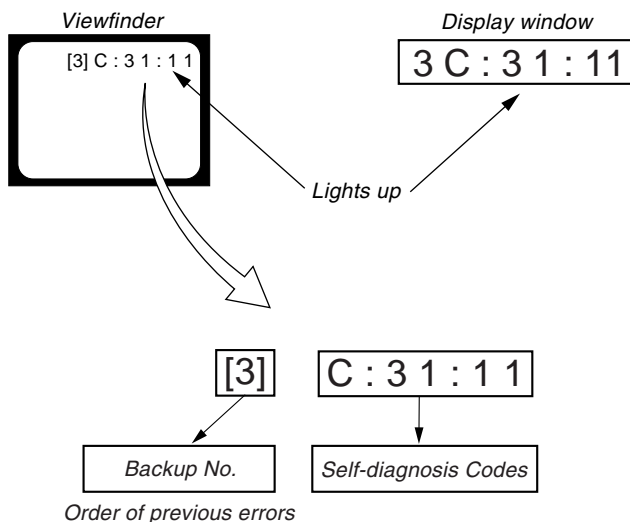

3-2. Switching of Backup No.

By rotating the control dial, past self-diagnosis codes will be shown in order. The backup No. in the [] indicates the order in which the problem occurred. (If the number of problems which occurred is less than 6, only the number of problems which occurred will be shown.)

- | | |
|----------------------------|------------------------------|
| [1] : Occurred first time | [4] : Occurred fourth time |
| [2] : Occurred second time | [5] : Occurred fifth time |
| [3] : Occurred third time | [6] : Occurred the last time |

3-3. End of Display

Turning OFF the power supply will end the service mode display.

Note: The “self-diagnosis display” data will be kept even if lithium battery (CF-2500 block BT001 of cabinet (R) assembly) is removed.

4. Self-diagnosis Code Table

Self-diagnosis Code				Symptom/State	Correction
Repaired by:	Block Function	Detailed Code			
C	0 4	0 0		Non-standard battery is used.	Use the InfoLITHIUM battery.
C	2 1	0 0		Condensation.	Remove the cassette, and insert it again after one hour.
C	2 2	0 0		Video head is dirty.	Clean with the optional cleaning cassette.
C	3 1	1 0		LOAD direction. Loading does not complete within specified time	Load the tape again, and perform operations from the beginning.
C	3 1	1 1		UNLOAD direction. Loading does not complete within specified time	Load the tape again, and perform operations from the beginning.
C	3 1	2 0		T reel side tape slacking when unloading.	Load the tape again, and perform operations from the beginning.
C	3 1	2 1		S reel side tape slacking when unloading.	Load the tape again, and perform operations from the beginning.
C	3 1	2 2		T reel fault.	Load the tape again, and perform operations from the beginning.
C	3 1	2 3		S reel fault.	Load the tape again, and perform operations from the beginning.
C	3 1	3 0		FG fault when starting capstan.	Load the tape again, and perform operations from the beginning.
C	3 1	3 1		FG fault during normal capstan operations.	Load the tape again, and perform operations from the beginning.
C	3 1	4 0		FG fault when starting drum.	Load the tape again, and perform operations from the beginning.
C	3 1	4 1		PG fault when starting drum.	Load the tape again, and perform operations from the beginning.
C	3 1	4 2		FG fault during normal drum operations.	Load the tape again, and perform operations from the beginning.
C	3 1	4 3		PG fault during normal drum operations.	Load the tape again, and perform operations from the beginning.
C	3 1	4 4		Phase fault during normal drum operations.	Load the tape again, and perform operations from the beginning.
C	3 2	1 0		LOAD direction loading motor time-out.	Remove the battery or power cable, connect, and perform operations from the beginning.
C	3 2	1 1		UNLOAD direction loading motor time-out.	Remove the battery or power cable, connect, and perform operations from the beginning.
C	3 2	2 0		T reel side tape slacking when unloading.	Remove the battery or power cable, connect, and perform operations from the beginning.
C	3 2	2 1		S reel side tape slacking when unloading.	Remove the battery or power cable, connect, and perform operations from the beginning.
C	3 2	2 2		T reel fault.	Remove the battery or power cable, connect, and perform operations from the beginning.
C	3 2	2 3		S reel fault.	Remove the battery or power cable, connect, and perform operations from the beginning.
C	3 2	3 0		FG fault when starting capstan.	Remove the battery or power cable, connect, and perform operations from the beginning.
C	3 2	3 1		FG fault during normal capstan operations.	Remove the battery or power cable, connect, and perform operations from the beginning.
C	3 2	4 0		FG fault when starting drum.	Remove the battery or power cable, connect, and perform operations from the beginning.
C	3 2	4 1		PG fault when starting drum.	Remove the battery or power cable, connect, and perform operations from the beginning.
C	3 2	4 2		FG fault during normal drum operations.	Remove the battery or power cable, connect, and perform operations from the beginning.
C	3 2	4 3		PG fault during normal drum operations.	Remove the battery or power cable, connect, and perform operations from the beginning.
C	3 2	4 4		Phase fault during normal drum operations.	Remove the battery or power cable, connect, and perform operations from the beginning.

DCR-TRV738E/TRV740/TRV740E/TRV840

Self-diagnosis Code			Symptom/State	Correction
Repaired by:	Block Function	Detailed Code		
E	6 1	0 0	Difficult to adjust focus (Cannot initialize focus.)	Inspect the lens block focus reset sensor (Pin ⑫ of CN1551 of VC-278 board) when focusing is performed when the focus ring is rotated in the focus manual mode and the focus motor drive circuit (IC1555 of VC-278 board) when the focusing is not performed.
E	6 1	1 0	Zoom operations fault (Cannot initialize zoom lens.)	Inspect the lens block zoom reset sensor (Pin ⑪ of CN1551 of VC-278 board) when zooming is performed when the zoom switch is operated and the zoom motor drive circuit (IC1555 of VC-278 board) when zooming is not performed.
E	6 2	0 0	Handshake correction function does not work well. (With pitch angular velocity sensor output stopped.)	Inspect pitch angular velocity sensor (SE301 of SE-032 board) peripheral circuits.
E	6 2	0 1	Handshake correction function does not work well. (With yaw angular velocity sensor output stopped.)	Inspect yaw angular velocity sensor (SE302 of SE-032 board) peripheral circuits.



SECTION 2 DISASSEMBLY

The following flow chart shows the disassembly procedure.

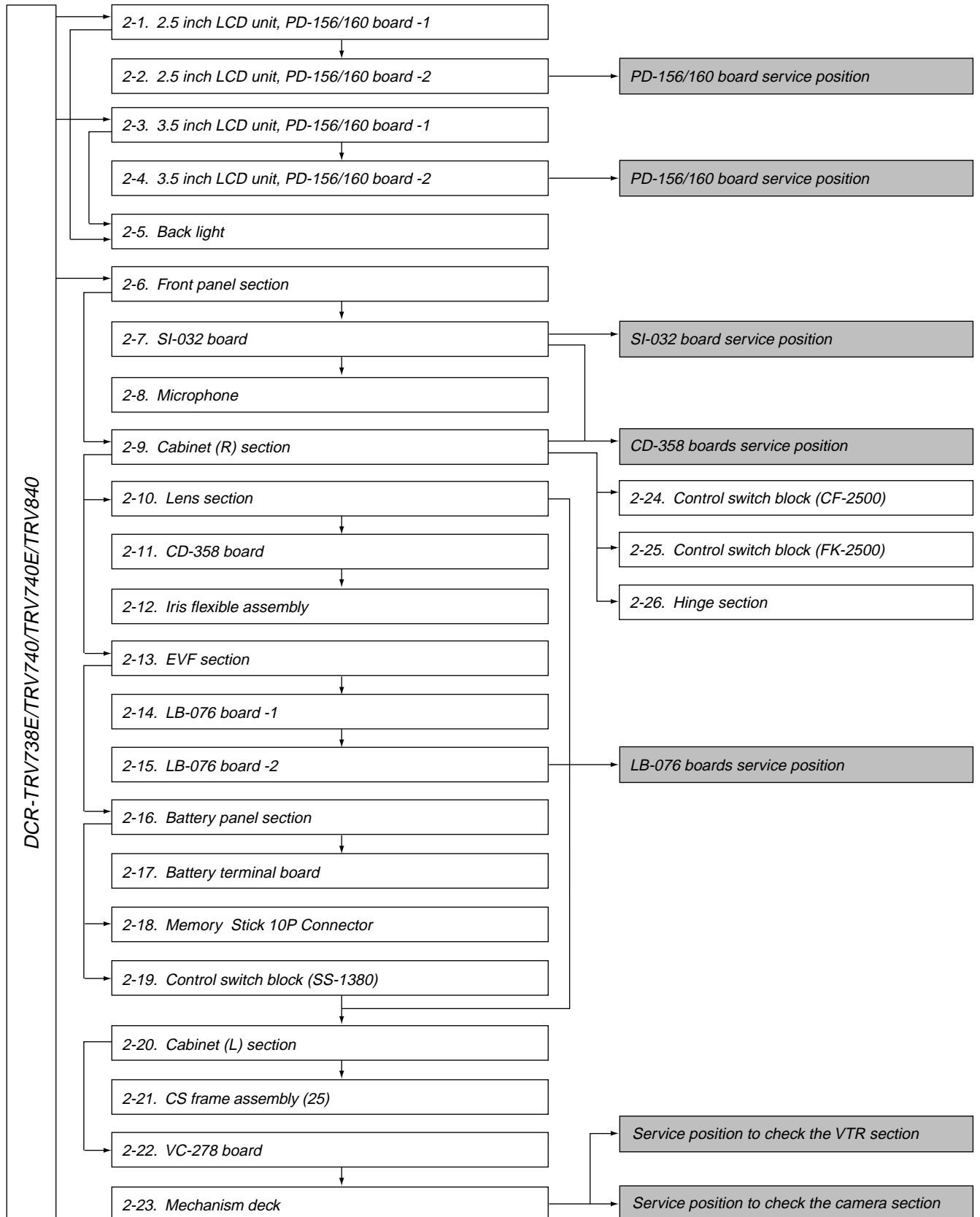

2.5 inch LCD model : TRV738E/TRV740/TRV740E
3.5 inch LCD model : TRV840

[CONNECTION OF EQUIPMENTS]

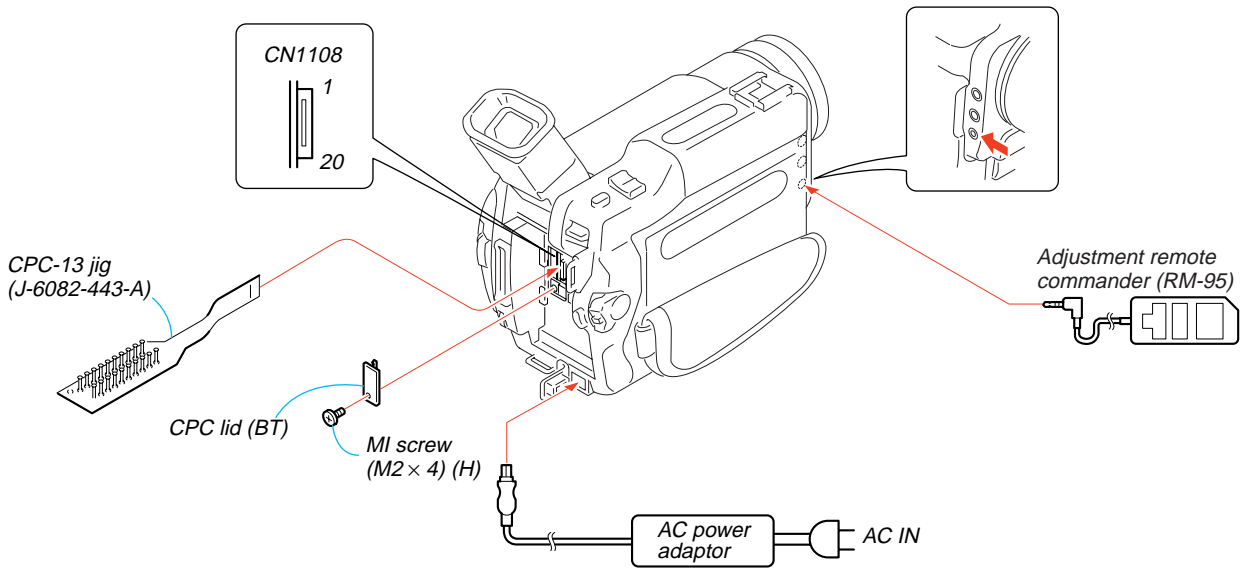

NOTE: Follow the disassembly procedure in the numerical order given.

2-1. 2.5 INCH LCD UNIT, PD-156/160 BOARD -1

NOTE: PD-156 board : TRV738E/TRV740E (AE,EE,NE,RU)

PD-160 board : TRV740/TRV740E (E,HK,AUS,CH,JE)

Refer to page 5-32 for 1-5-1. "LCD Type Check" of this manual for the detail.

- HK : Hong Kong model
- AUS : Australian model
- CH : Chinese model
- JE : Tourist model
- EE : East European model
- NE : North European model
- RU : Russian model

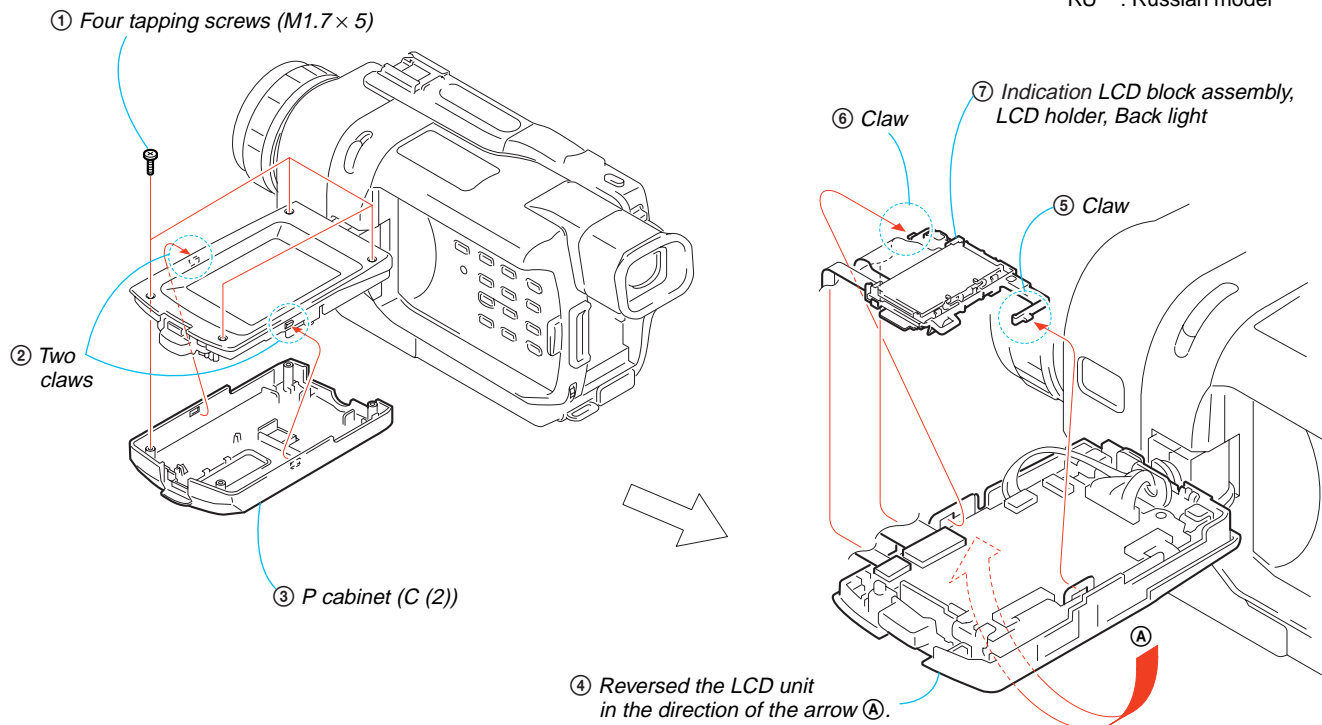

2-2. 2.5 INCH LCD UNIT, PD-156/160 BOARD -2

NOTE: PD-156 board : TRV738E/TRV740E (AEP,EE,NE,RU)
 PD-160 board : TRV740/TRV740E (E,HK,AUS,CH,JE)
 Refer to page 5-32 for 1-5-1. "LCD Type Check" of this manual for the detail.

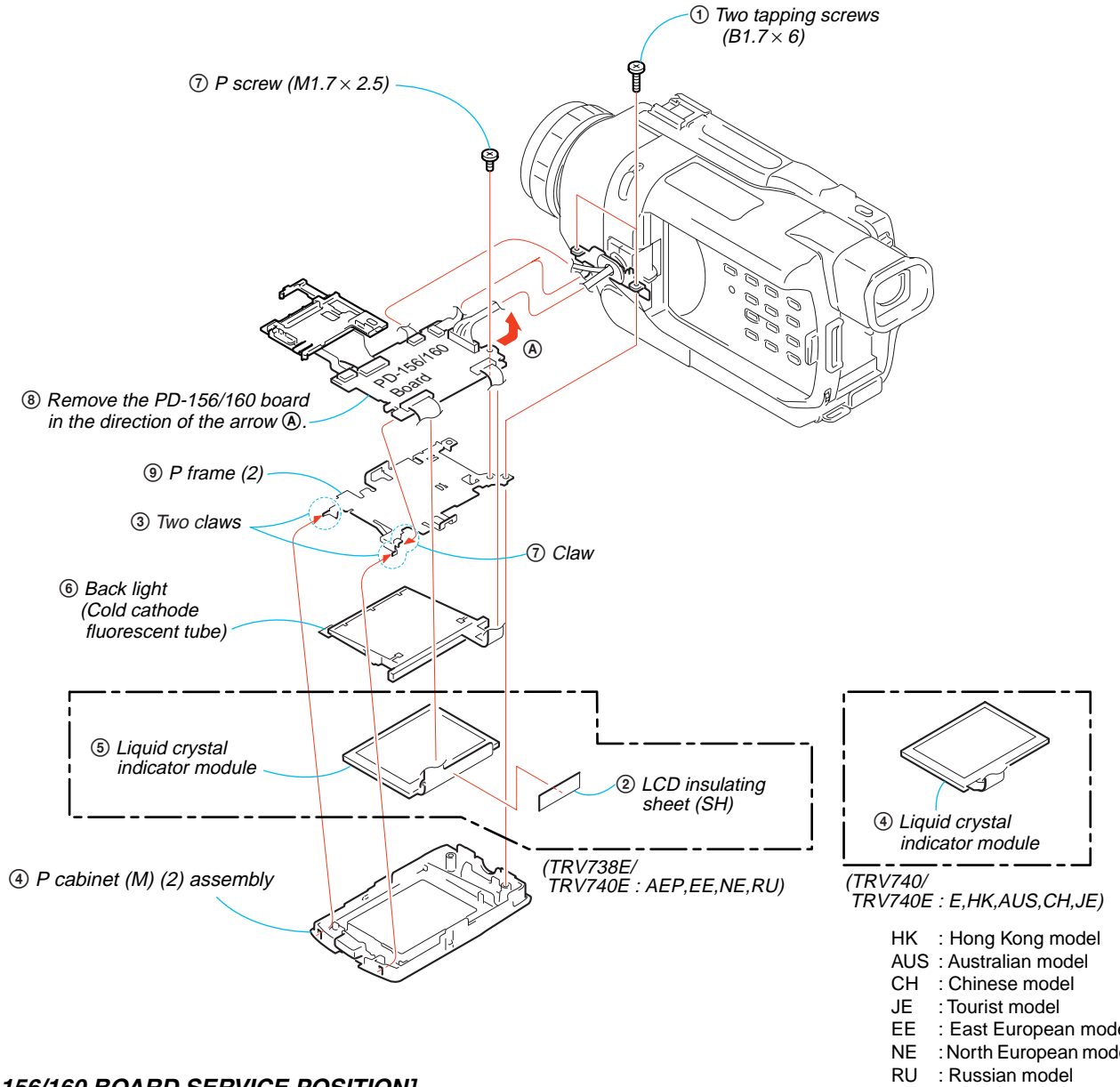

[PD-156/160 BOARD SERVICE POSITION]

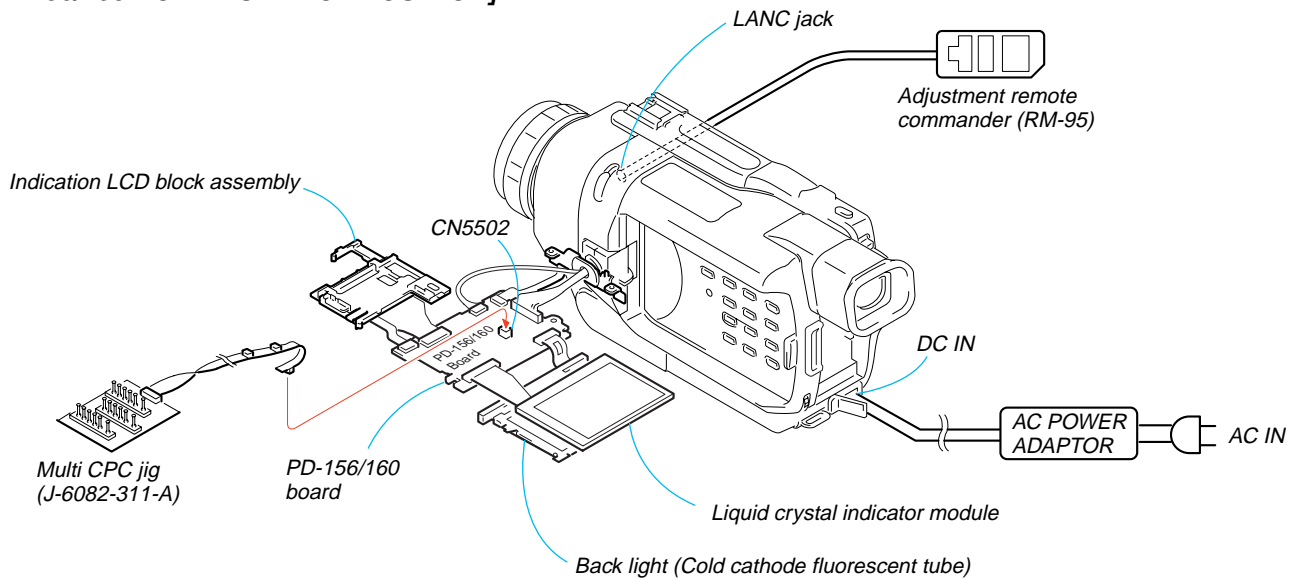

2-3. 3.5 INCH LCD UNIT, PD-156/160 BOARD -1

NOTE: 3.5 inch LCD model is TRV840 only.

Refer to page 5-32 for 1-5-1. "LCD Type Check" of this manual for the detail.

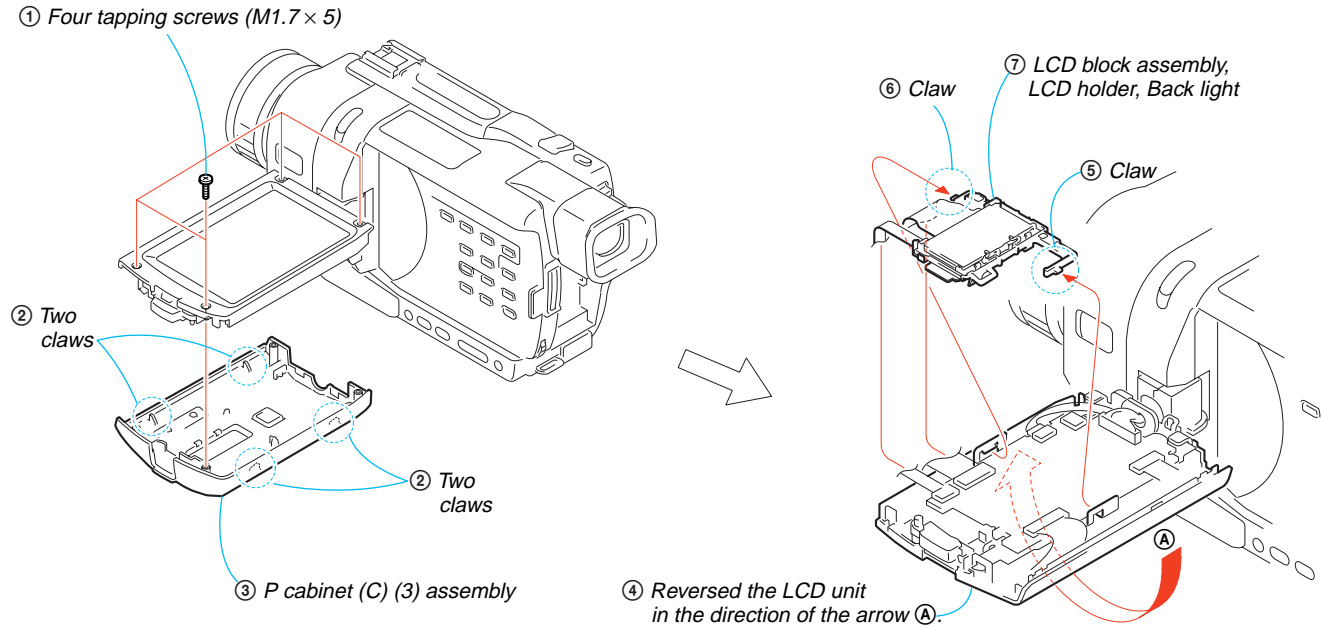

2-4. 3.5 INCH LCD UNIT, PD-156/160 BOARD -2

NOTE: 3.5 inch LCD model is TRV840 only.

Refer to page 5-32 for 1-5-1. "LCD Type Check" of this manual for the detail.

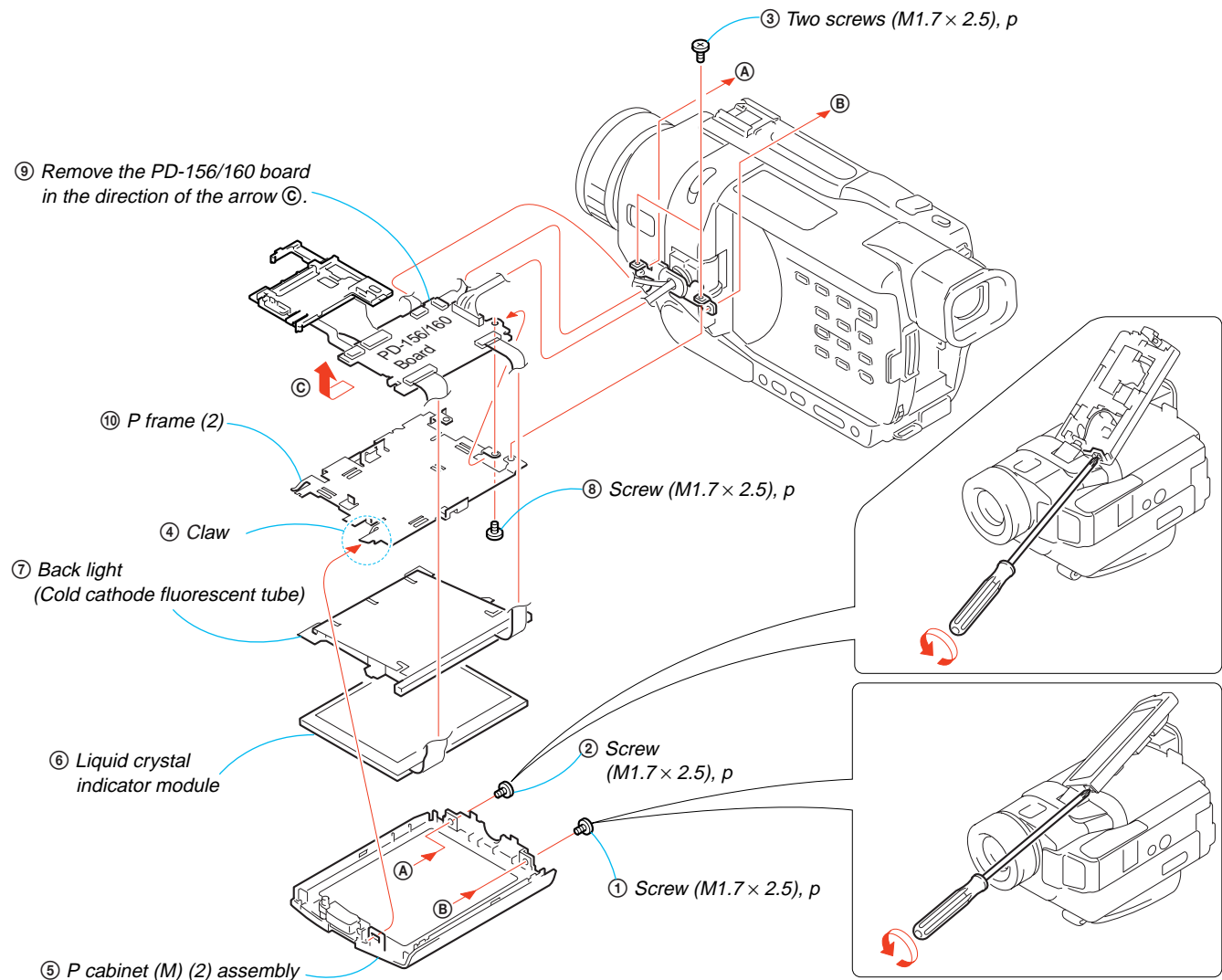

[PD-156/160 BOARD SERVICE POSITION]

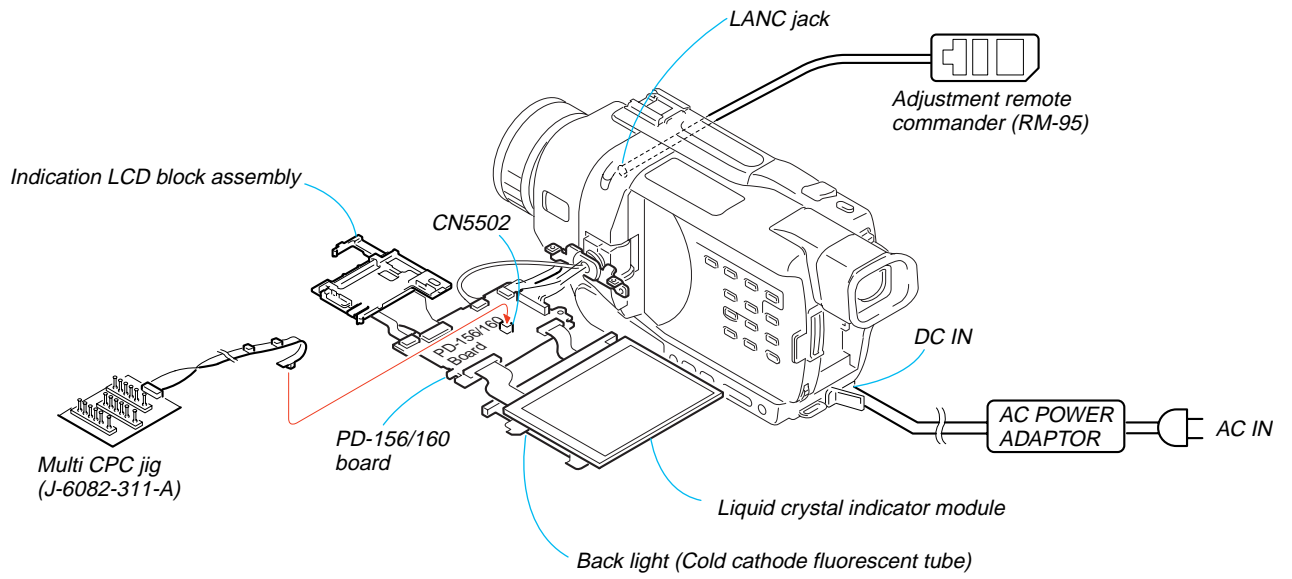

2-5. BACK LIGHT

⑤ Remove the indication LCD block assembly in the direction of the arrow ⑥.

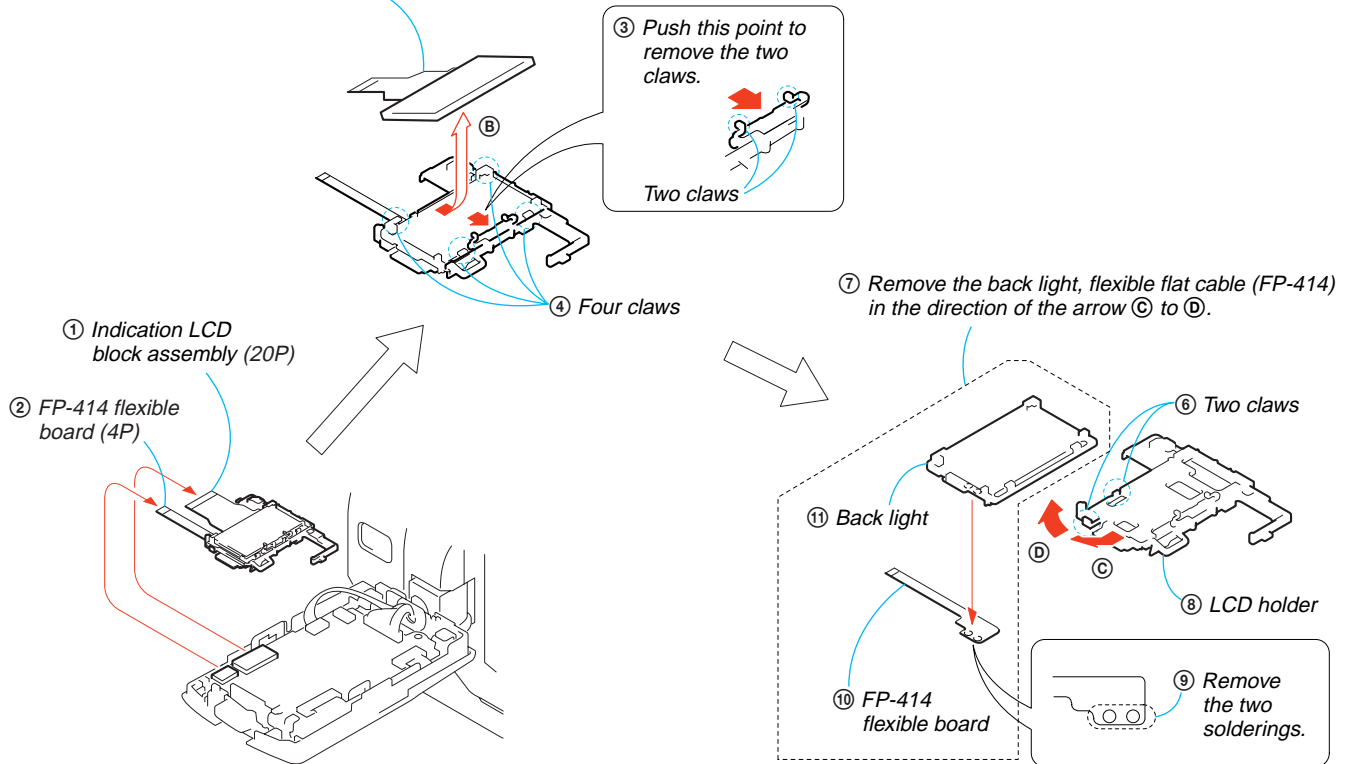

2-6. FRONT PANEL SECTION

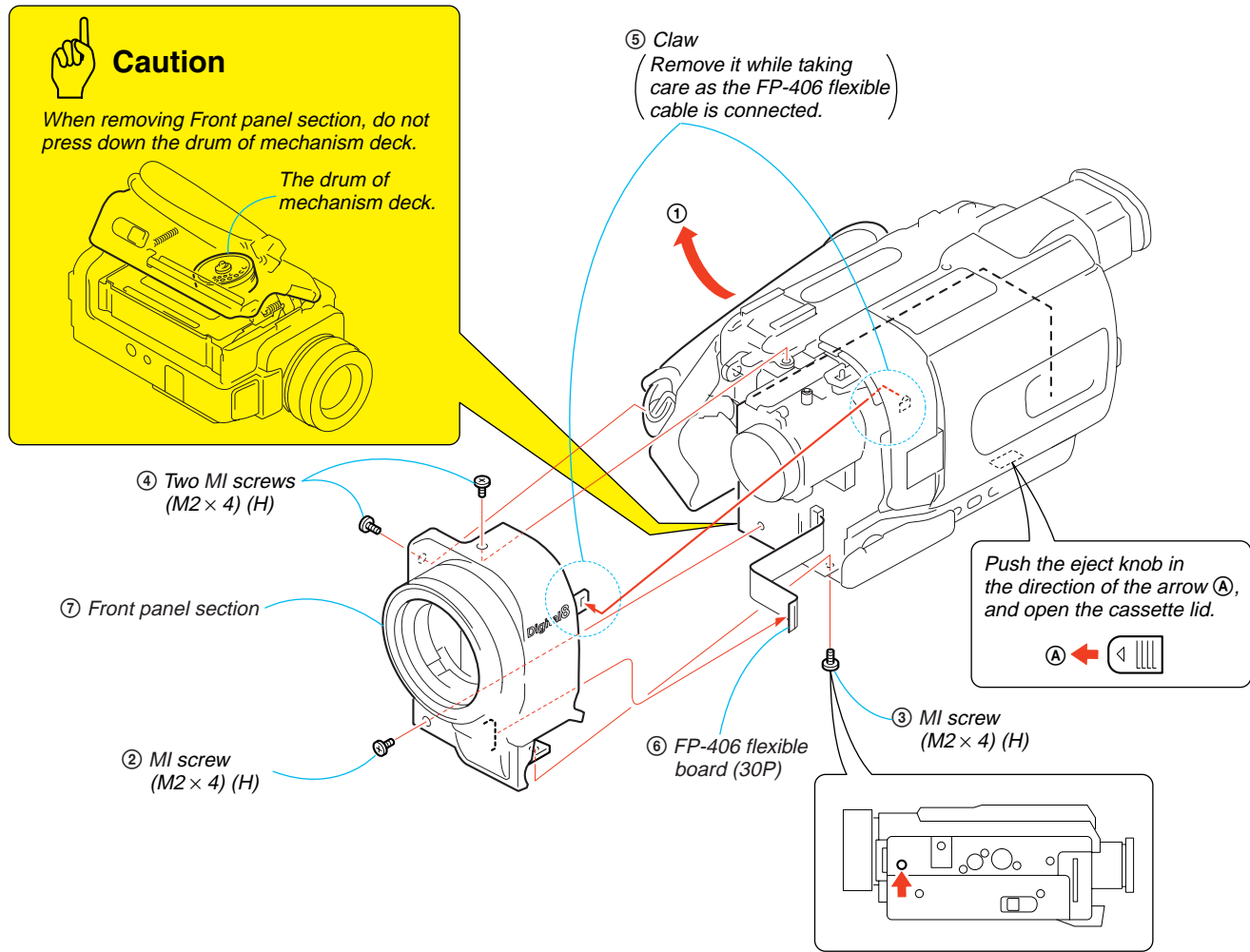

2-7. SI-032 BOARD

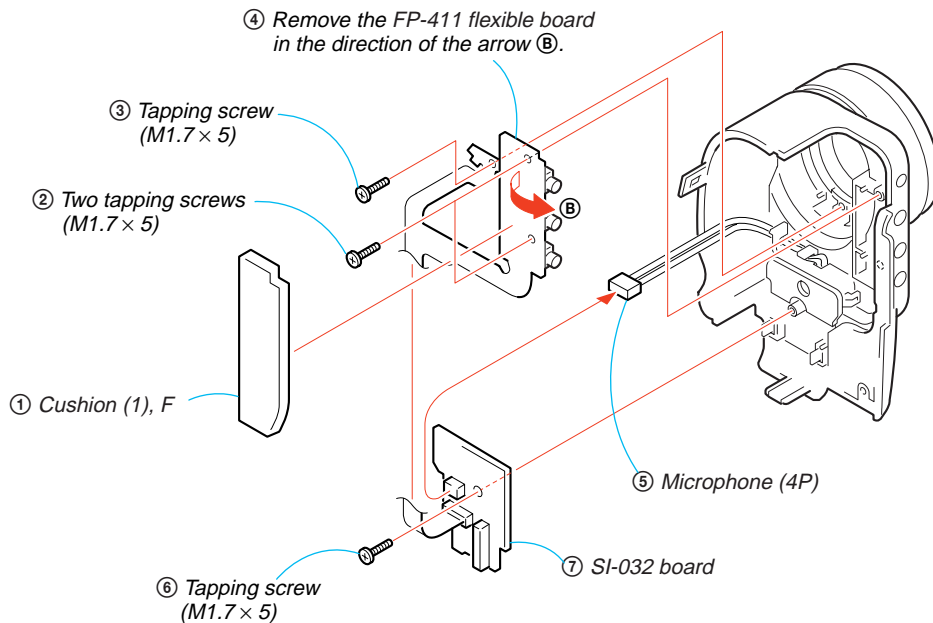

[SI-032 BOARD SERVICE POSITION]

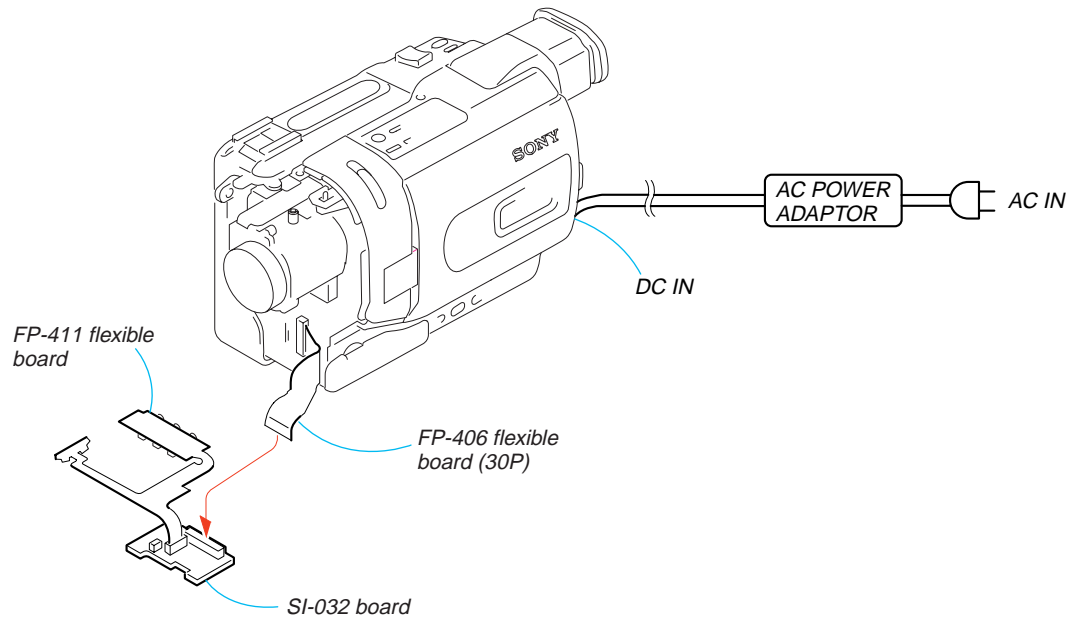

2-8. MICROPHONE

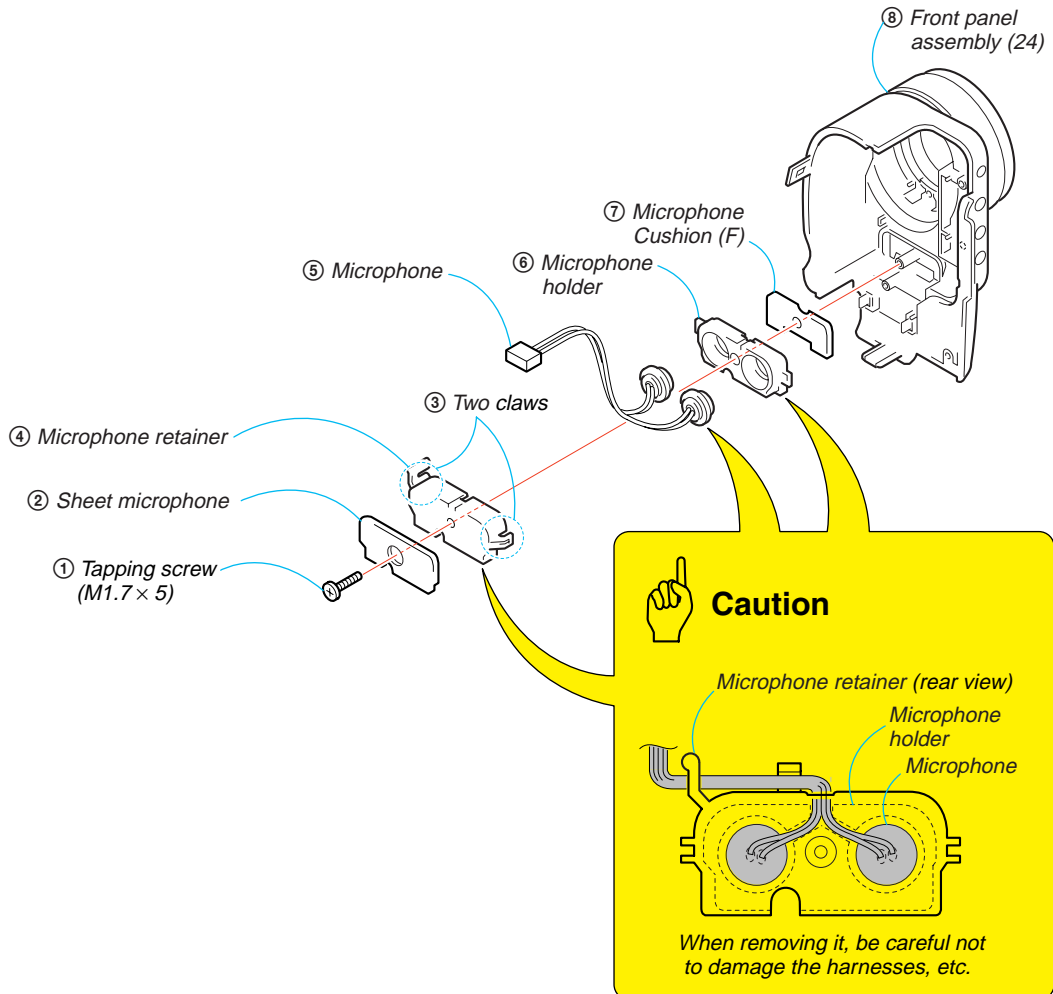

2-9. CABINET (R) SECTION

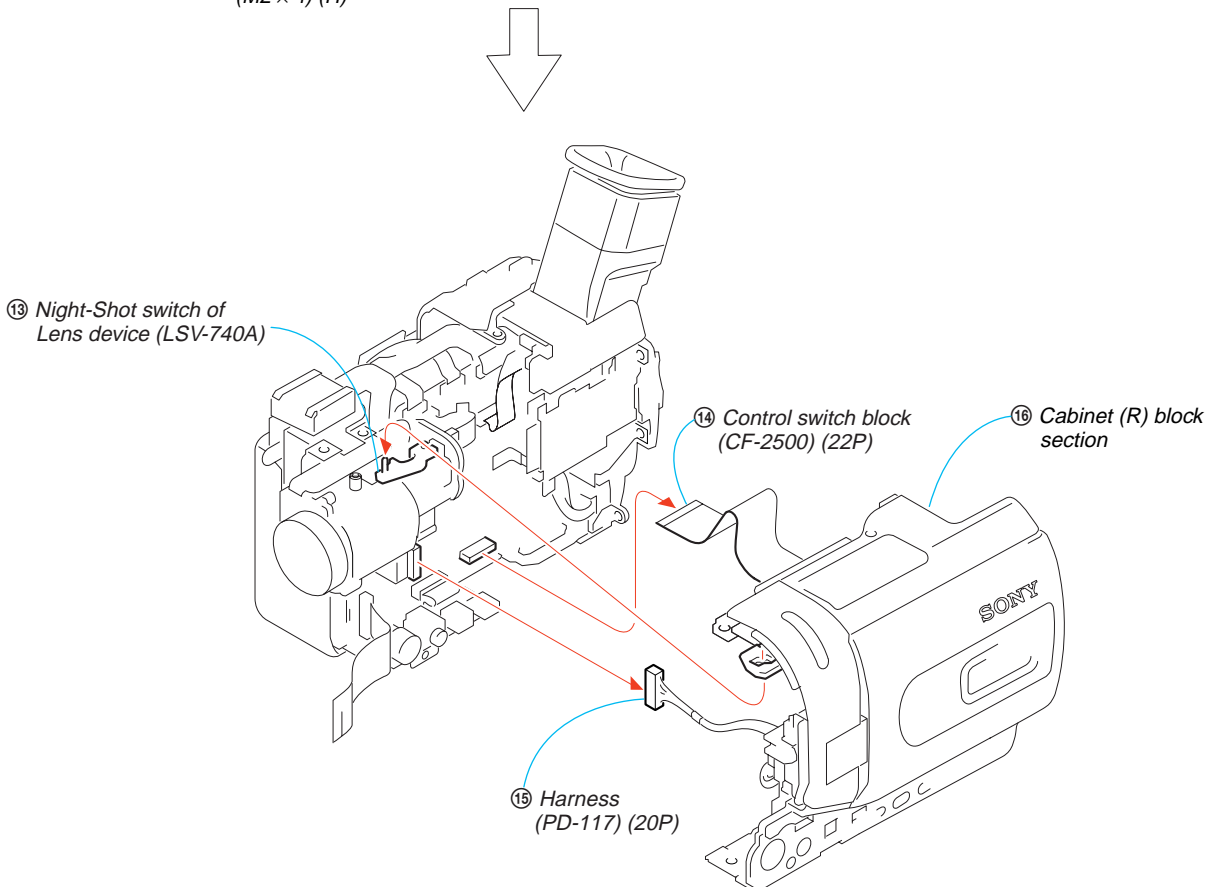
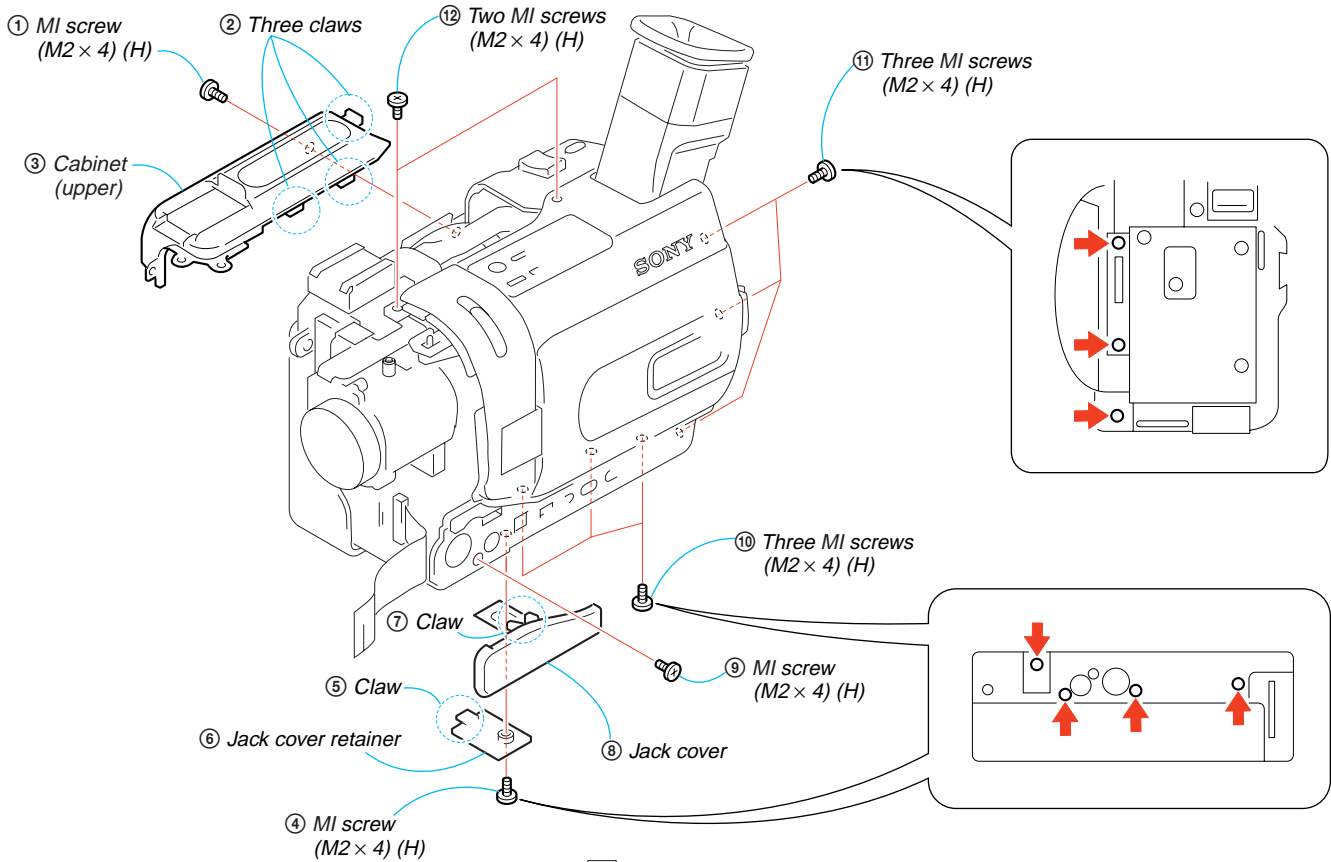

2-10.LENS SECTION

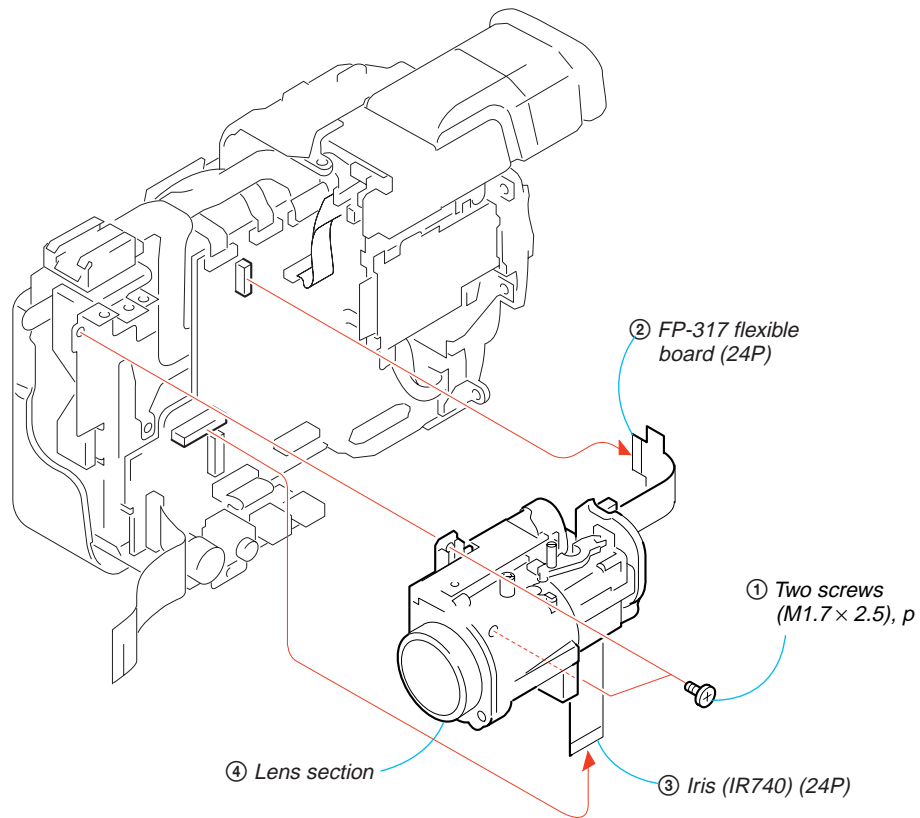

2-11.CD-358 BOARD

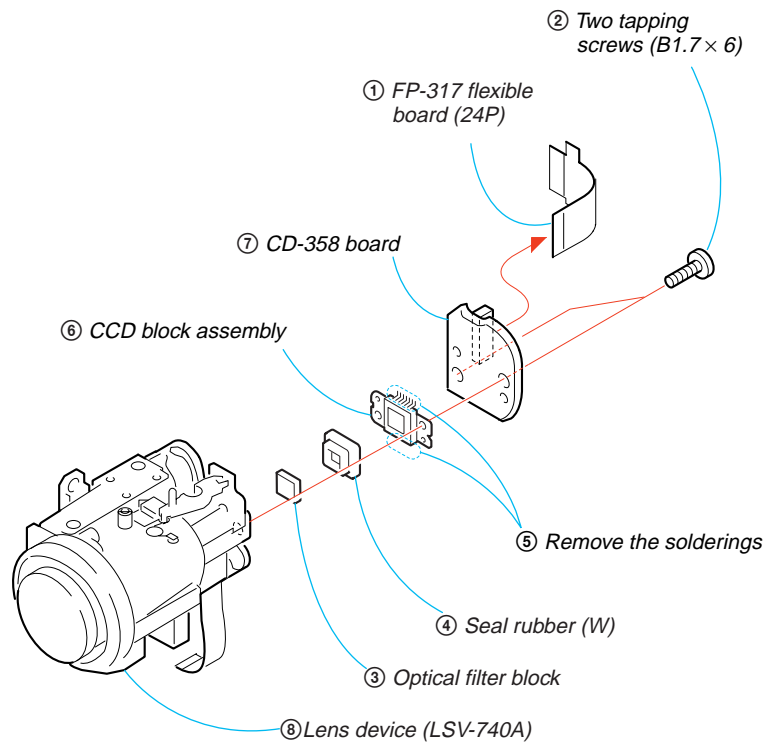

[CD-358 BOARD SERVICE POSITION]

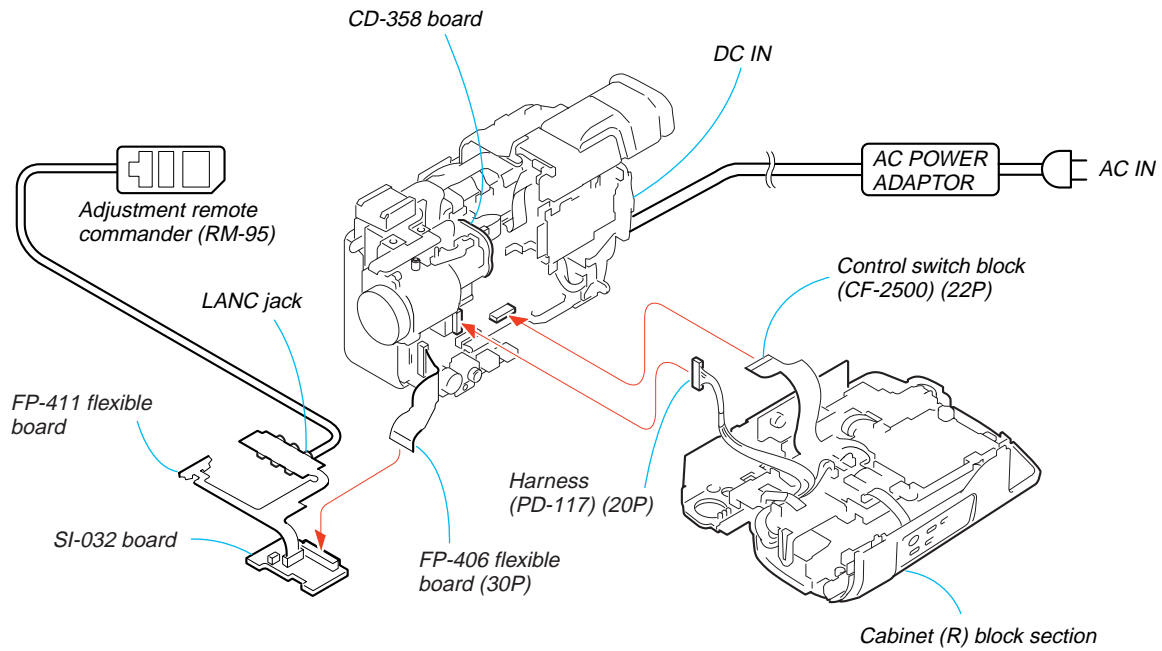

2-12. IRIS FLEXIBLE ASSEMBLY

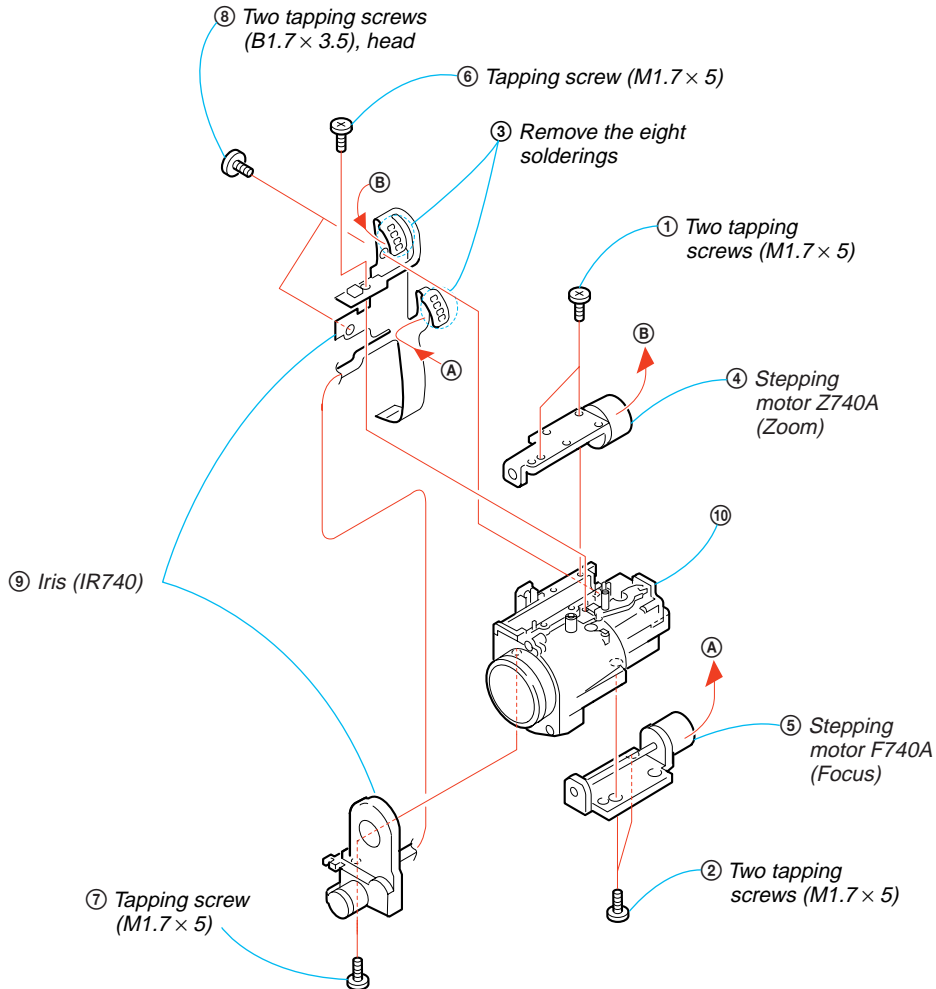

2-13. EVF SECTION

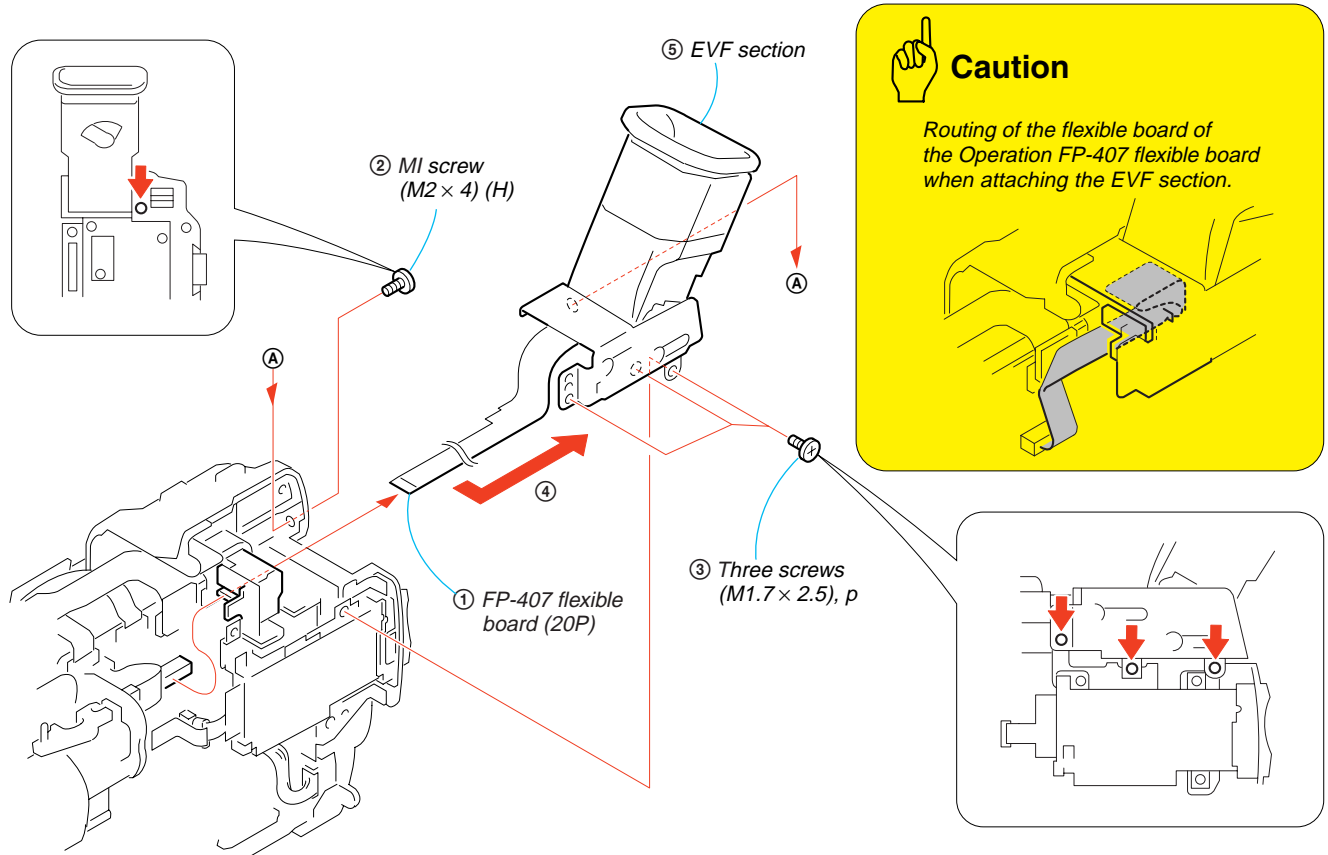

2-14. LB-076 BOARD -1

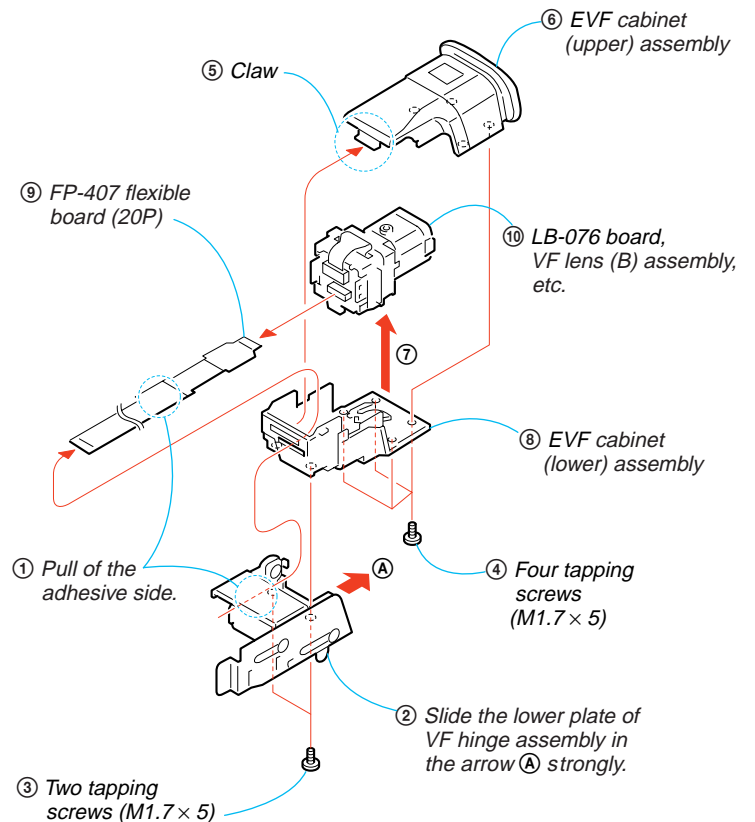
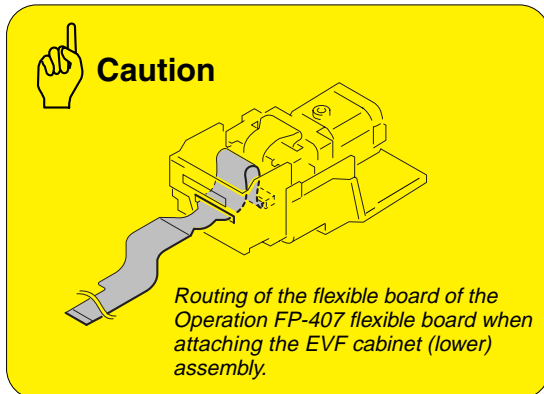
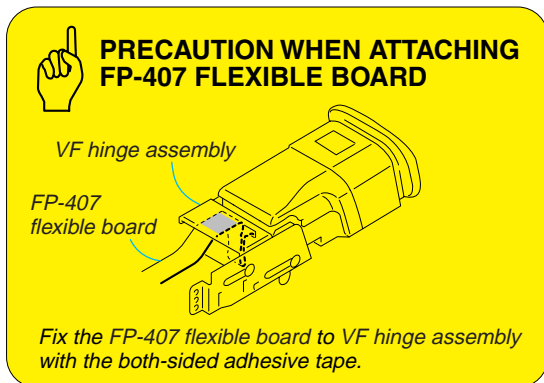

2-15.LB-076 BOARD -2

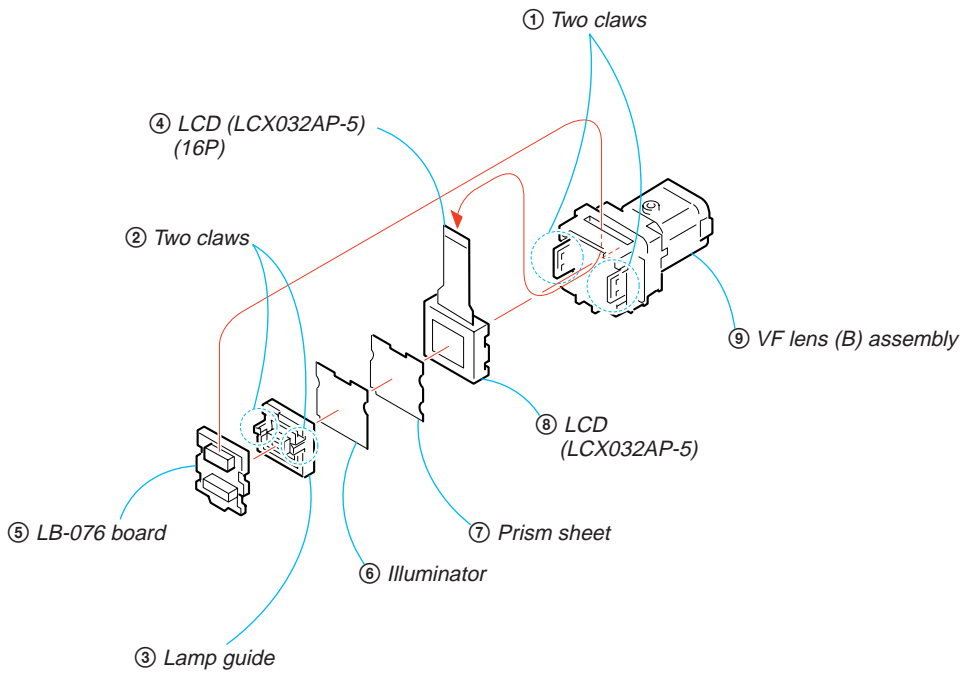

[LB-076 BOARD SERVICE POSITION]

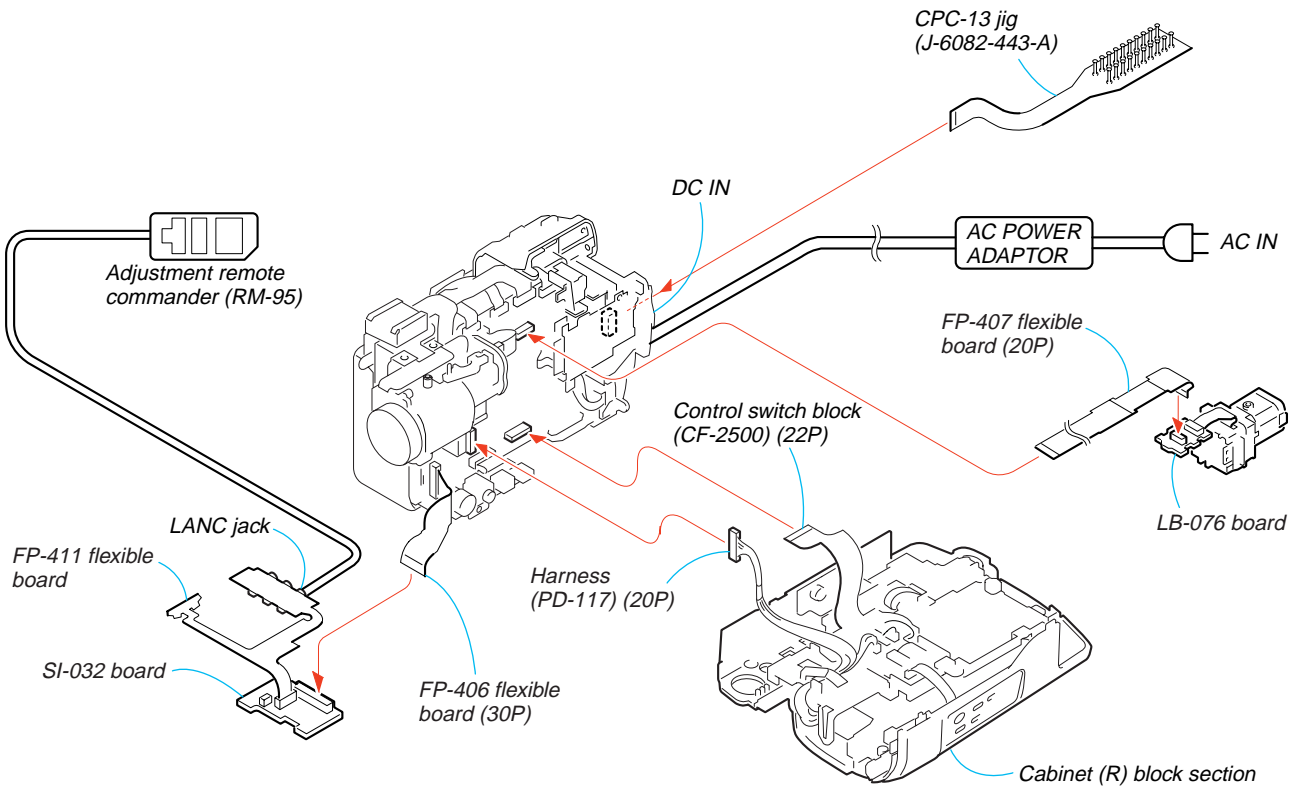

2-16. BATTERY PANEL SECTION

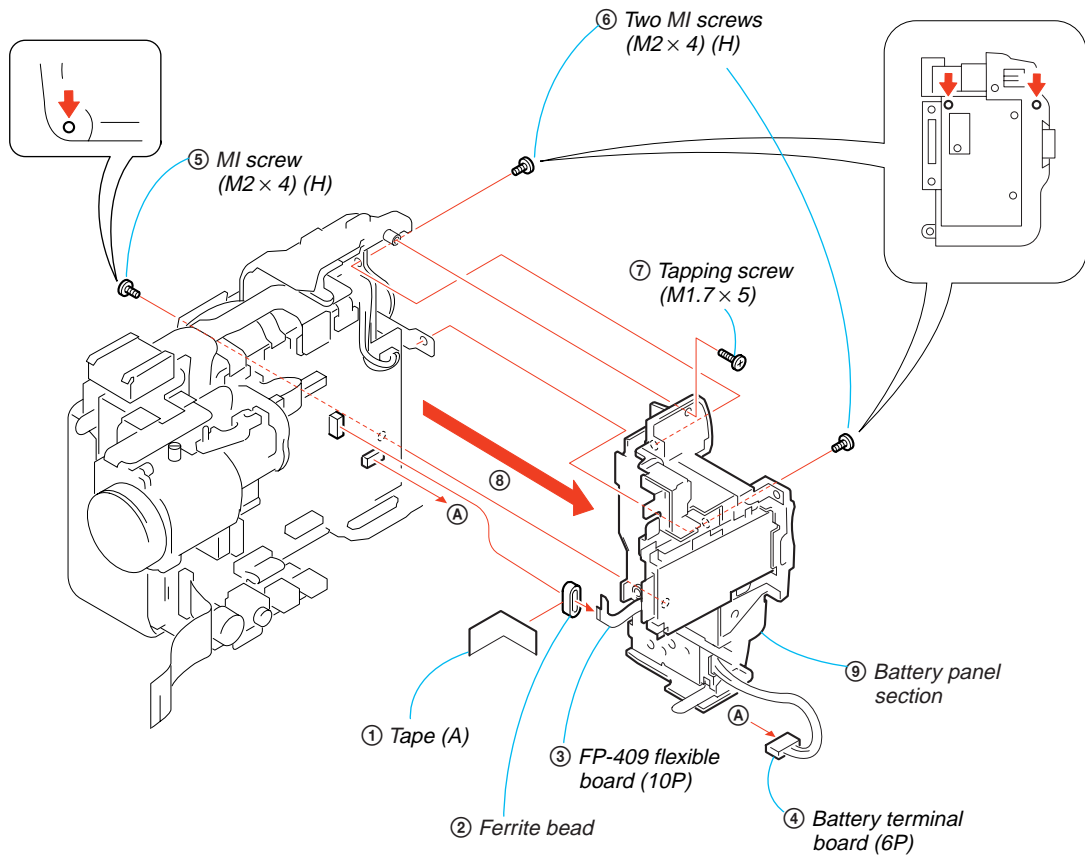

2-17. BATTERY TERMINAL BOARD

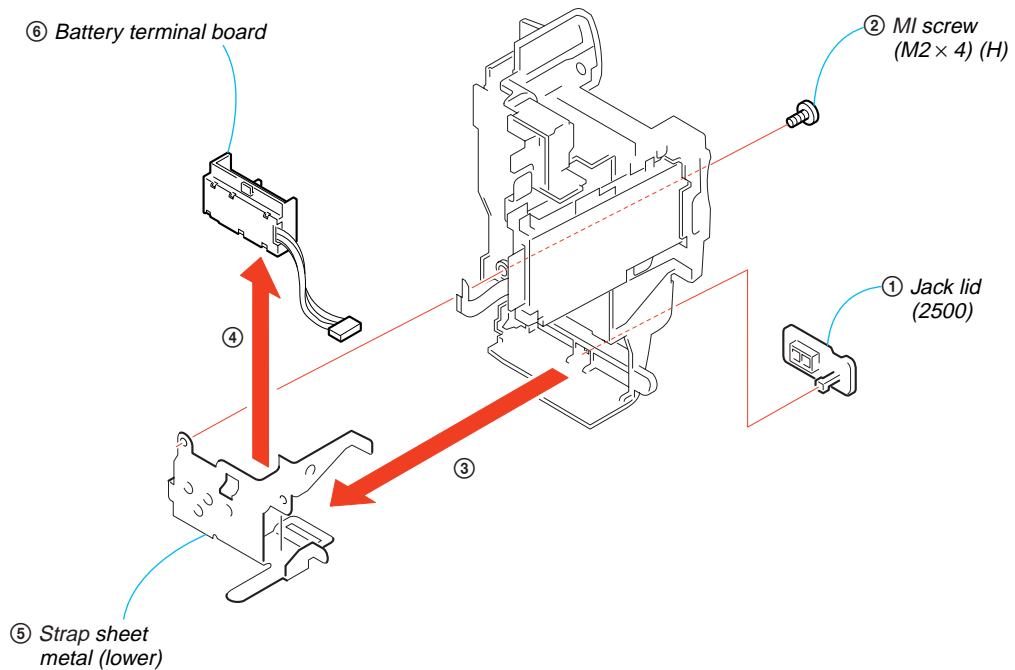

2-18. MEMORY STICK 10P CONNECTOR

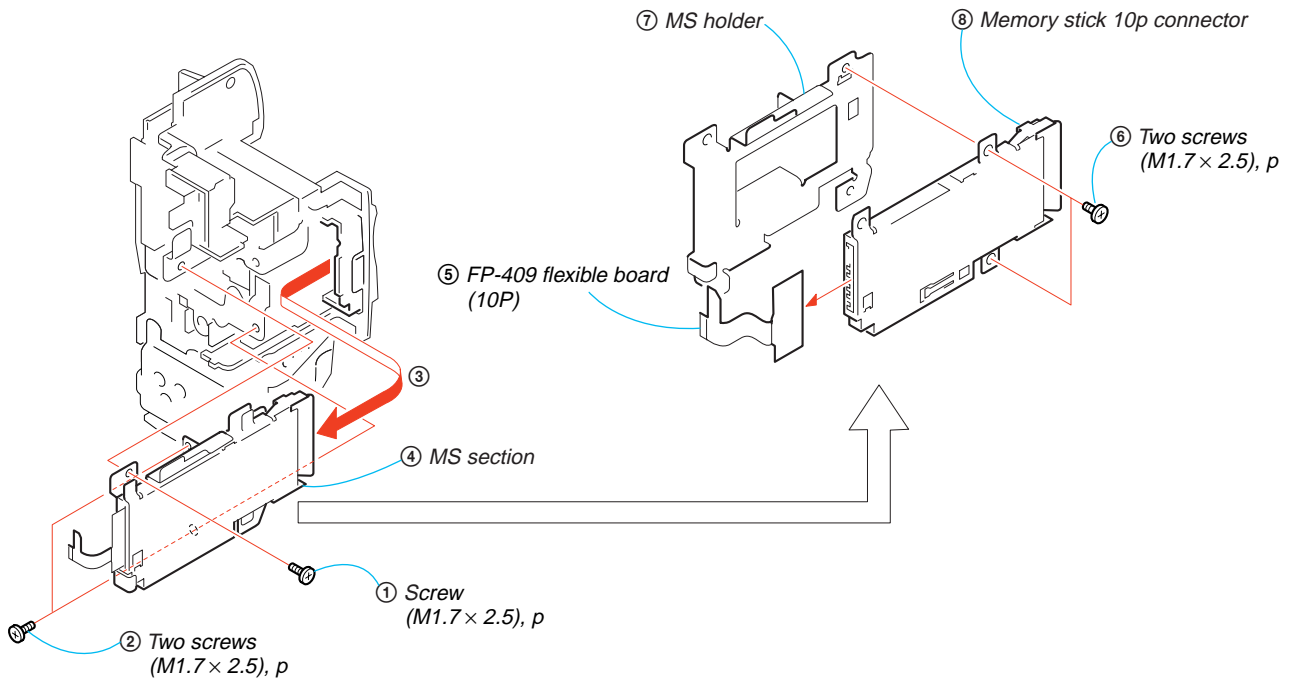

2-19. CONTROL SWITCH BLOCK (SS-1380)

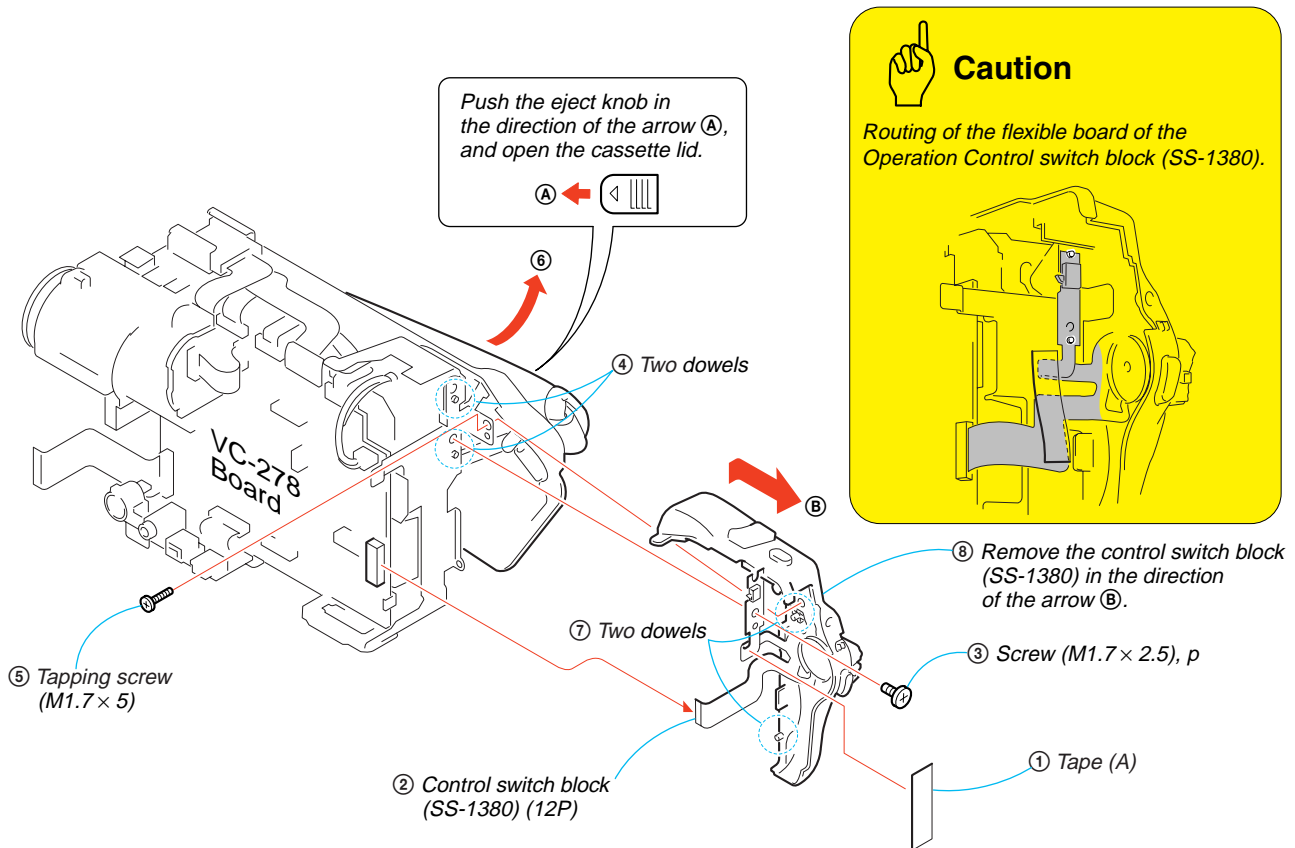

2-20. CABINET (L) SECTION

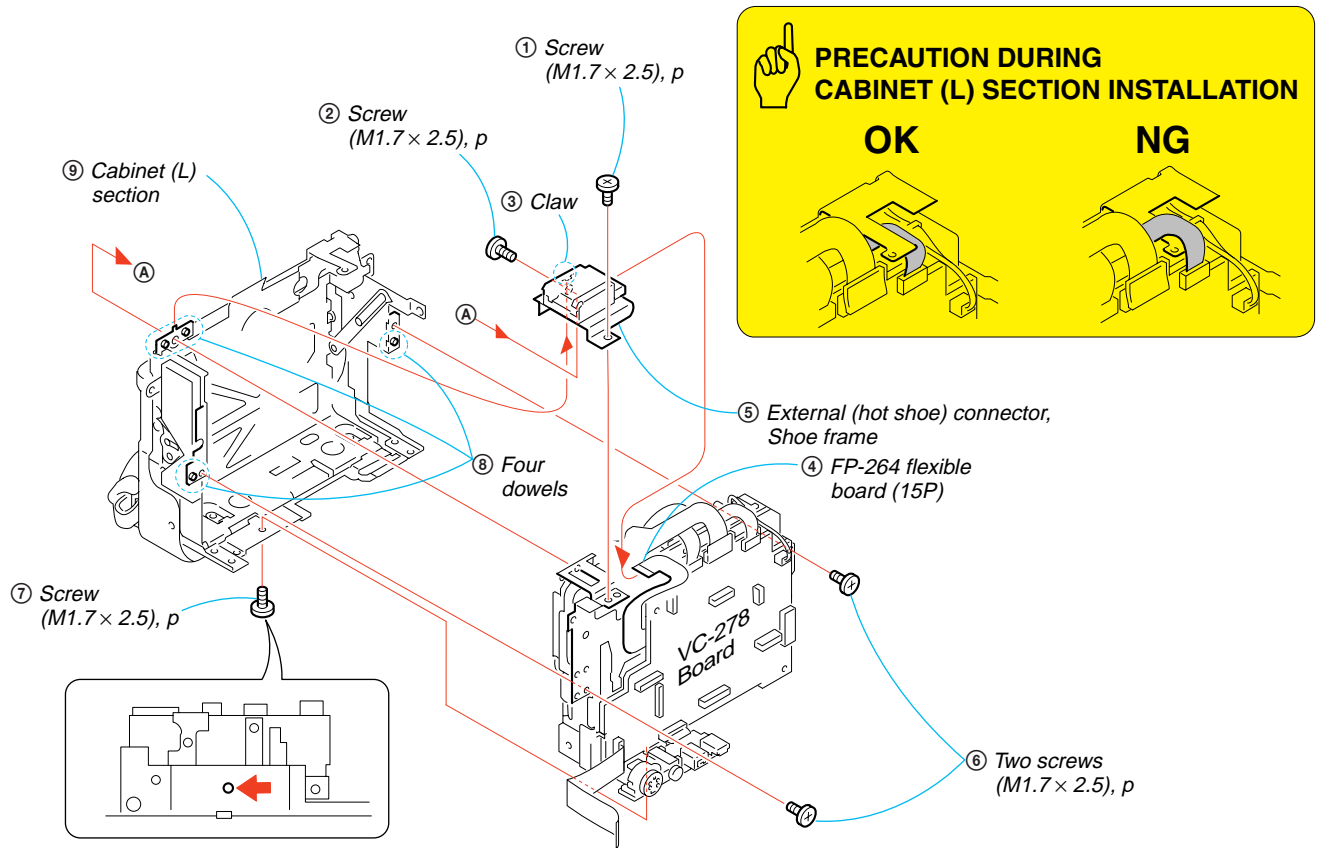

2-21. CS FRAME ASSEMBLY (25)

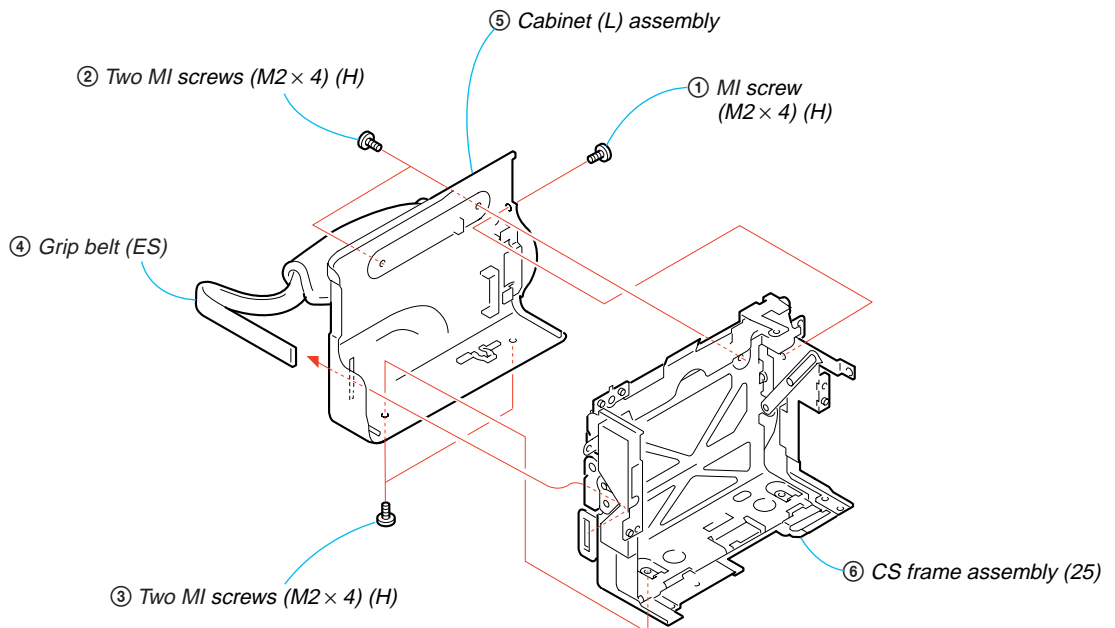

2-22.VC-278 BOARD

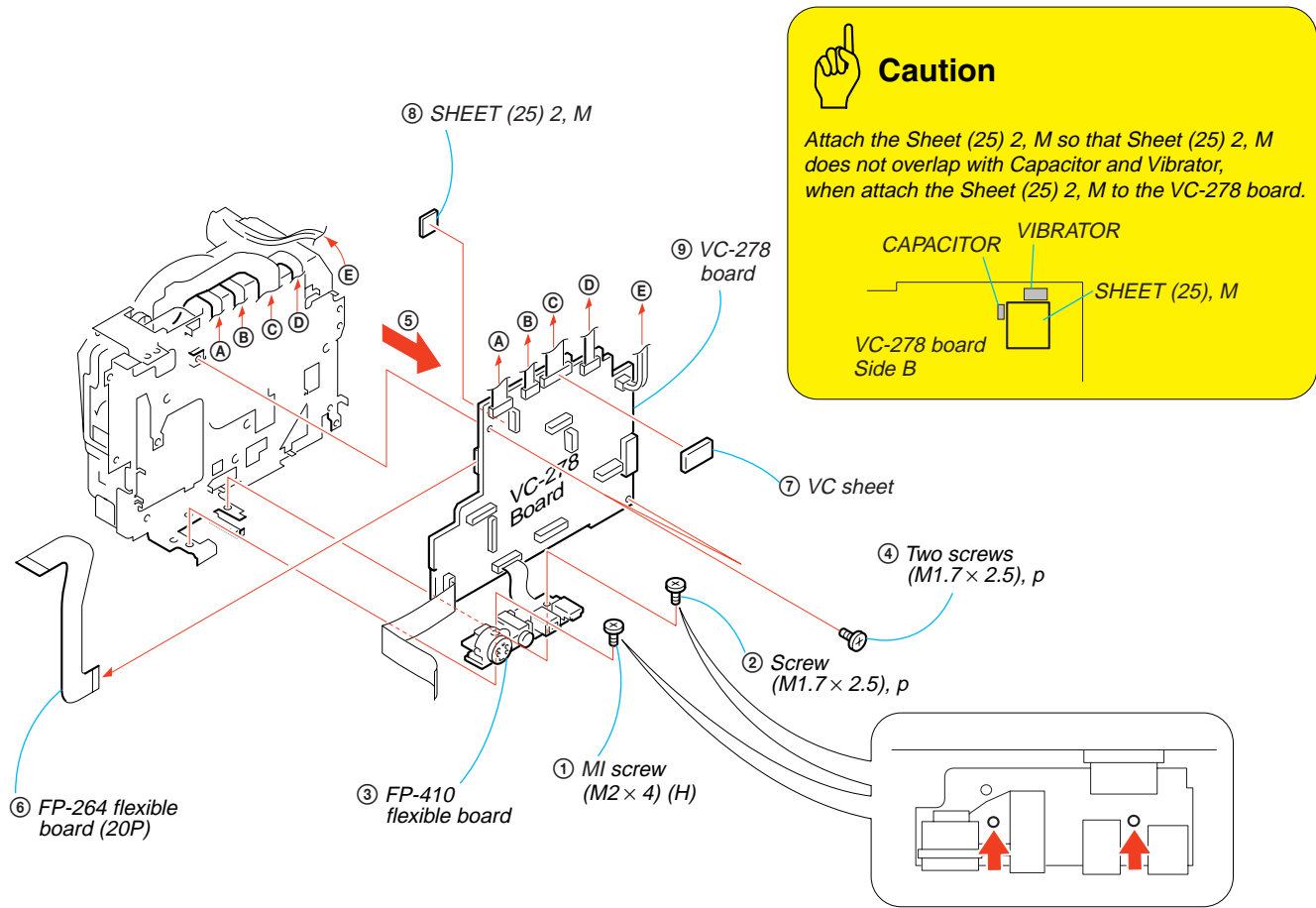

2-23.MECHANISM DECK

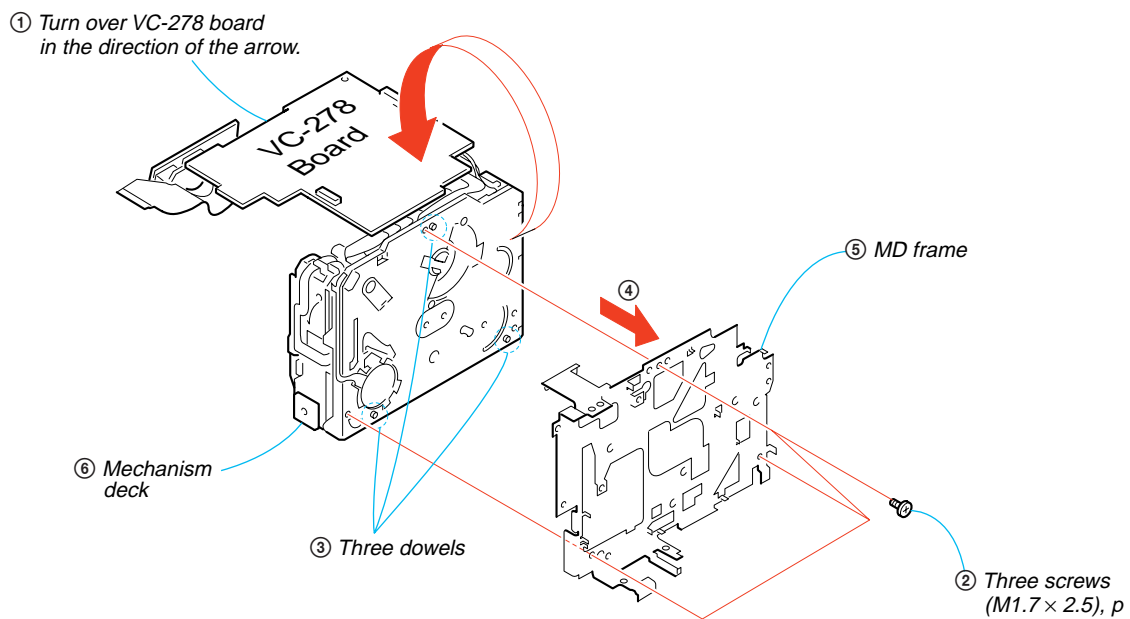

[SERVICE POSITION TO CHECK THE VTR SECTION]**Connection to Check the VTR Section**

To check the VTR section, set the VTR to the "Forced VTR power ON" mode.

Operate the VTR functions using the adjustment remote commander (with the HOLD switch set in the OFF position).

Setting the "Forced VTR Power ON" mode

- 1) Select page: 0, address: 01, and set data: 01.
- 2) Select page: 0, address: 10, and set data: 00.
- 3) Select page: D, address: 10, set data: 02 and press the PAUSE button of the adjustment remote commander.

Exiting the "Forced VTR Power ON" mode

- 1) Select page: 0, address: 01, and set data: 01.
- 2) Select page: 0, address: 10, and set data: 00.
- 3) Select page: D, address: 10, set data: 00, and press the PAUSE button of the adjustment remote commander.
- 4) Select page: 0, address: 01, and set data: 00.

Note : If the machine malfunctions (the operating mode changes by itself), connect the Cabinet (R) section.

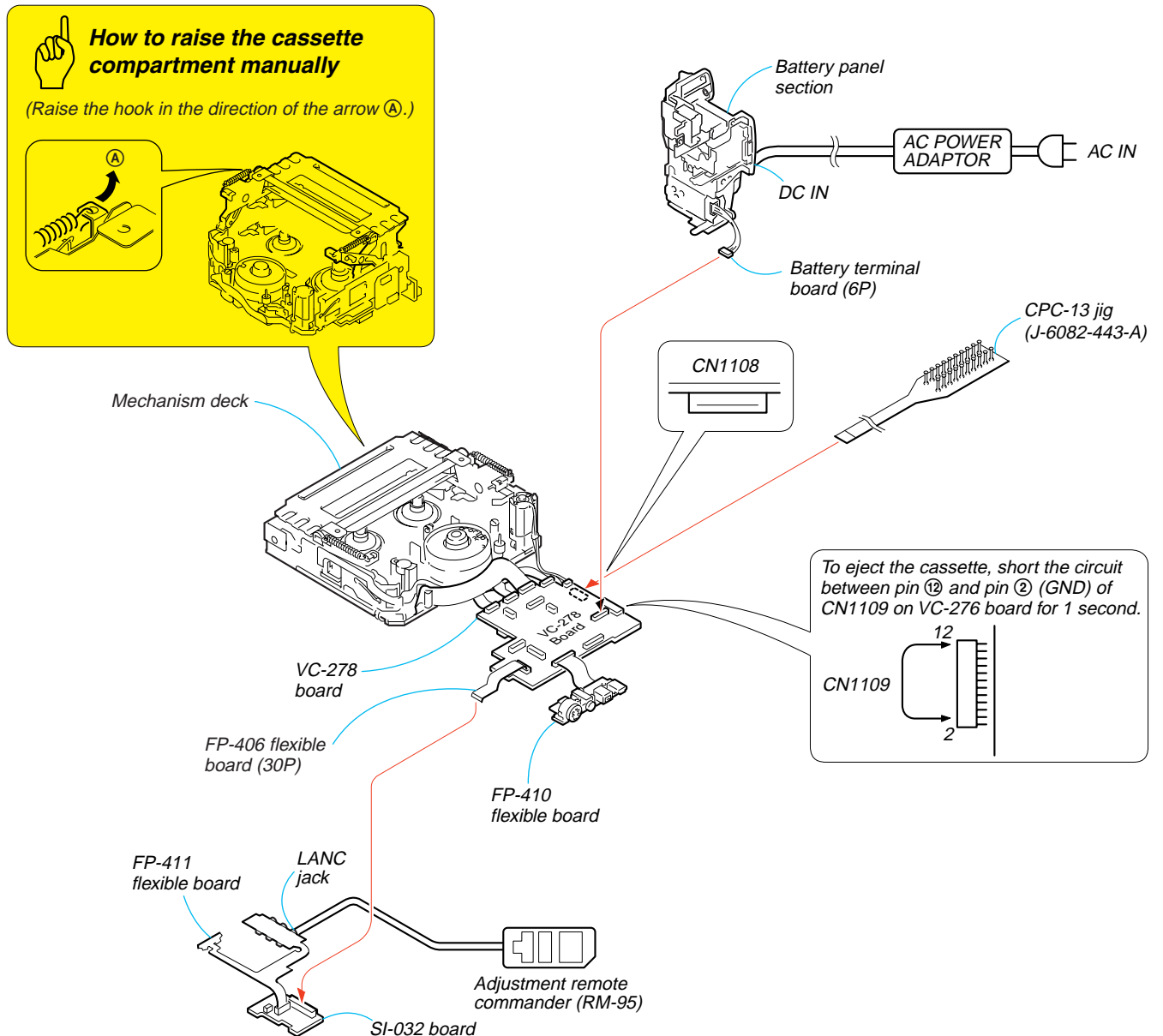

[SERVICE POSITION TO CHECK THE CAMERA SECTION]

Connection to Check the Camera Section

To check the camera section, set the camera to the "Forced camera power ON" mode.

When you want to operate to focus, use the controls on the remote commander (with the HOLD switch off).

When you want to operate to zoom, connect the controls switch block (SS-1380).

Setting the "Forced Camera Power ON" mode

- 1) Select page: 0, address: 01, and set data: 01.
- 2) Select page: 0, address: 10, and set data: 00.
- 3) Select page: D, address: 10, set data: 01 and press the PAUSE button of the adjustment remote commander.

Exiting the "Forced Camera Power ON" mode

- 1) Select page: 0, address: 01, and set data: 01.
- 2) Select page: 0, address: 10, and set data: 00.
- 3) Select page: D, address: 10, set data: 00, and press the PAUSE button of the adjustment remote commander.
- 4) Select page : 0, address: 01, and set data: 00.

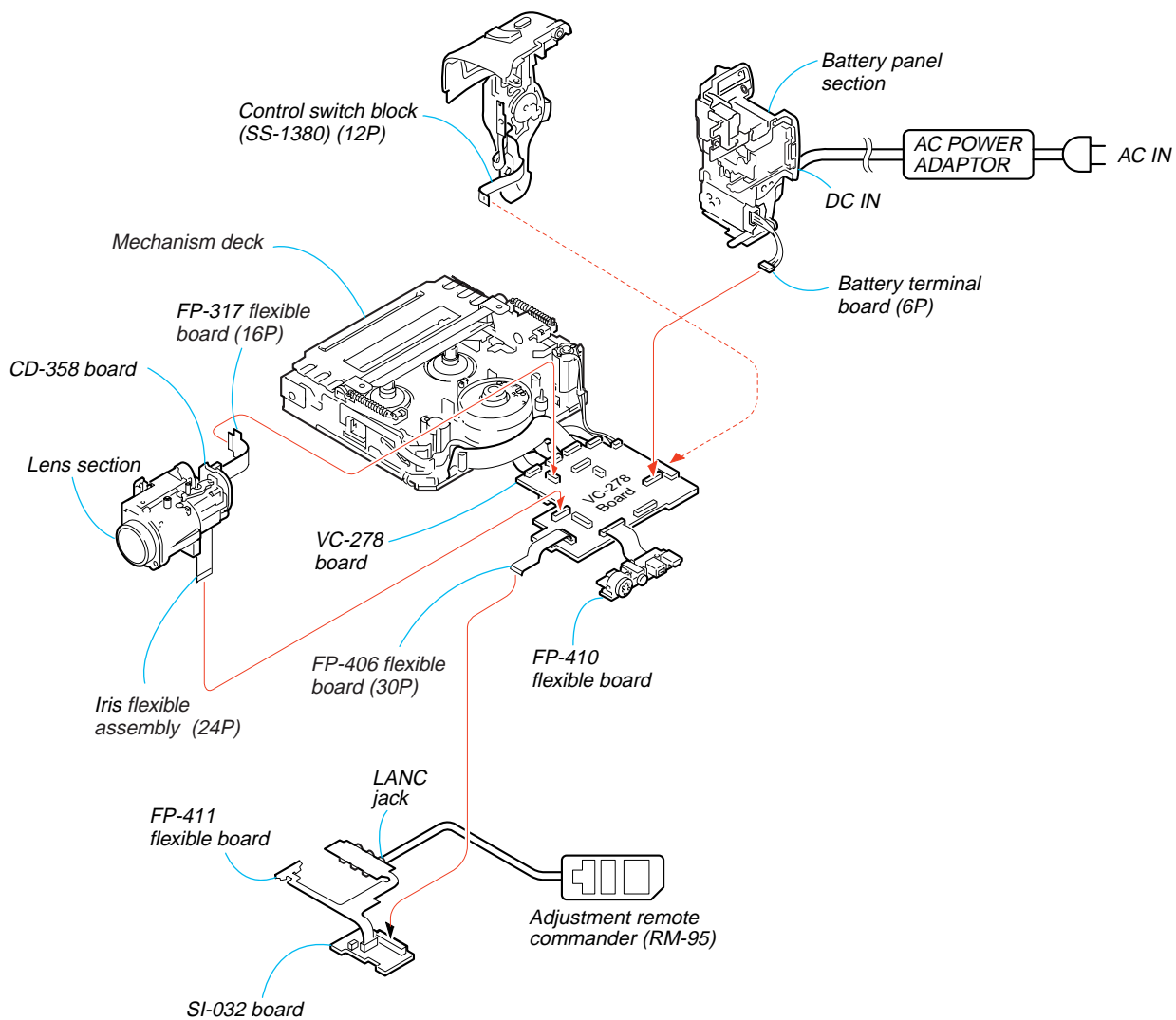

2-24.CONTROL SWITCH BLOCK (CF-2500)

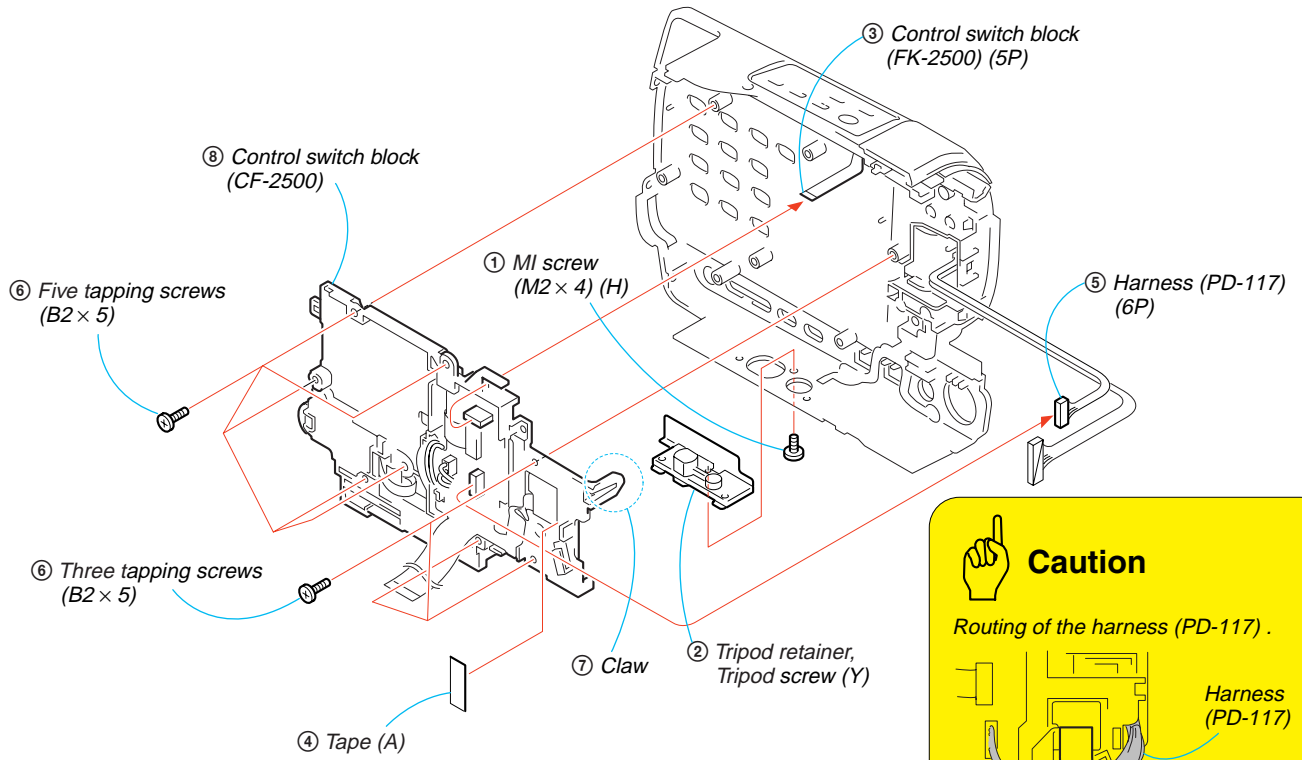

Caution

Routing of the harness (PD-117) .

Harness (PD-117)

Tape (A)

2-25.CONTROL SWITCH BLOCK (FK-2500)

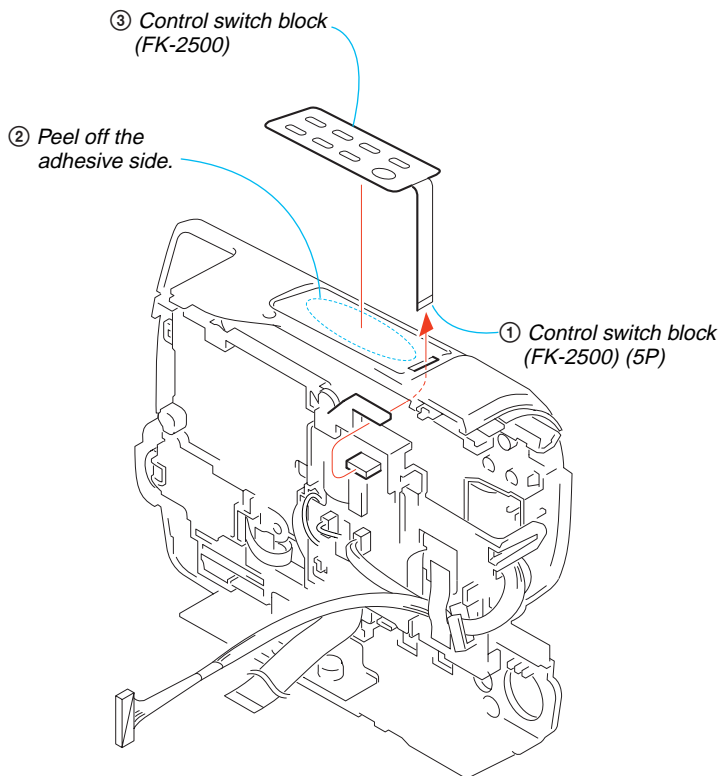

Caution

Routing of the flexible board of the Operation Control switch block (FK-2500).

2-26. HINGE SECTION

REMOVING THE HINGE ASSEMBLY

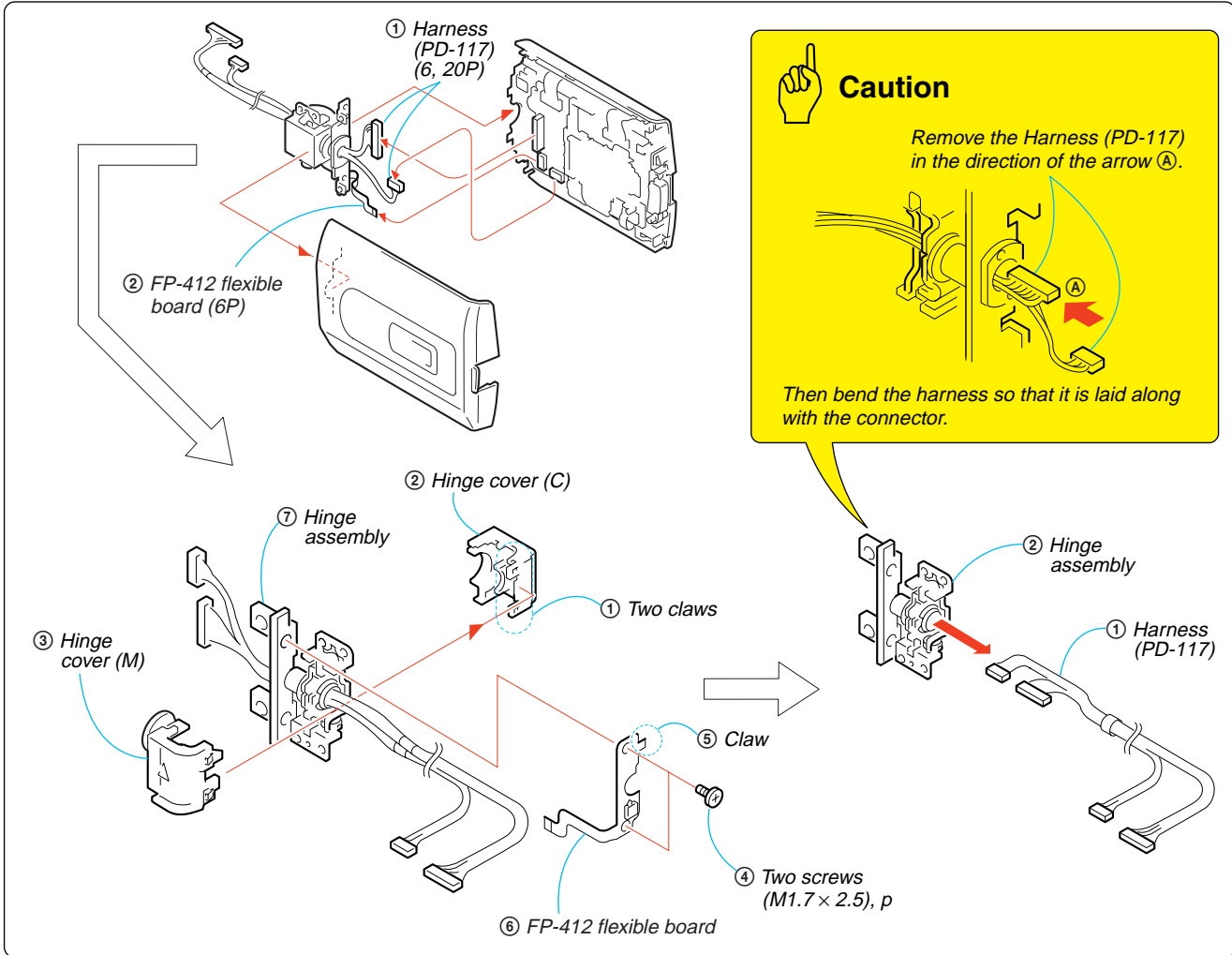

⑦ For removing the LCD unit
(See page 2-2 to 2-3 (2.5 inch LCD model),
2-4(3.5 inch LCD model))

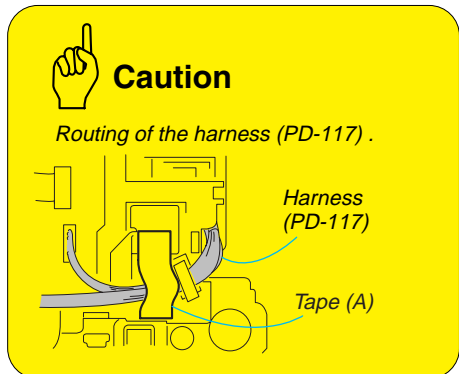
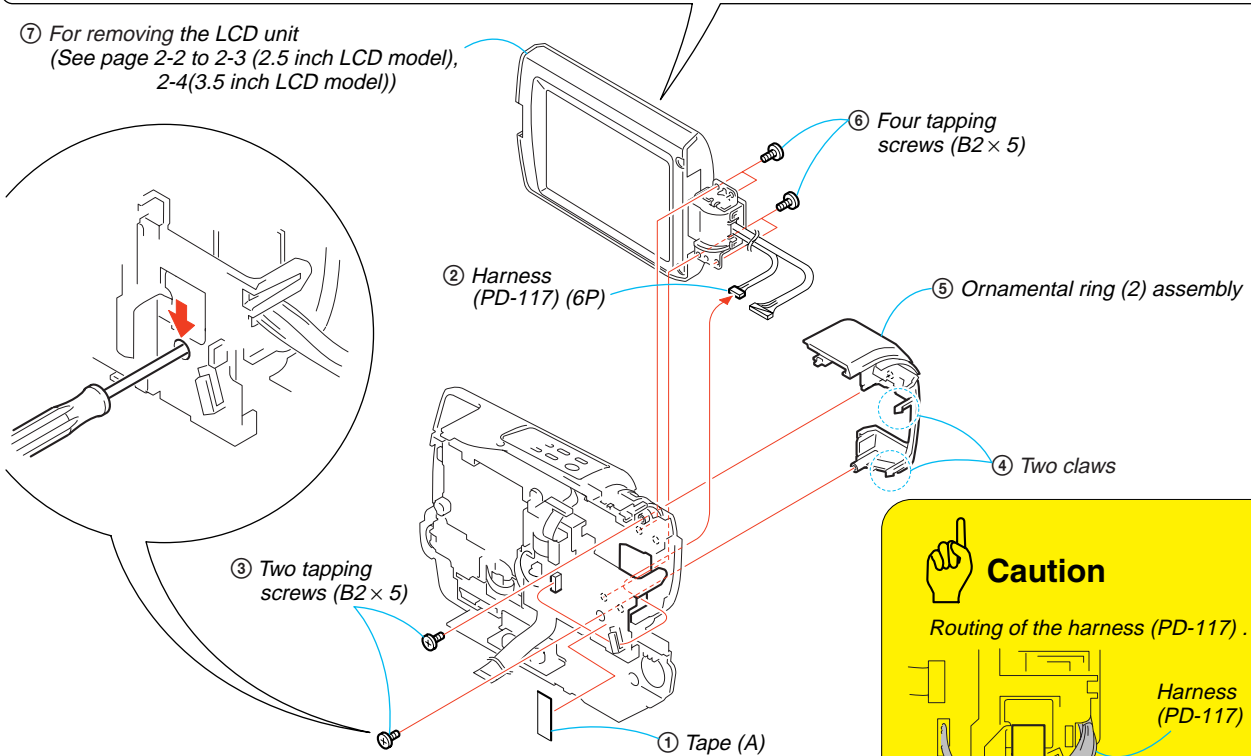



2-27. CIRCUIT BOARDS LOCATION

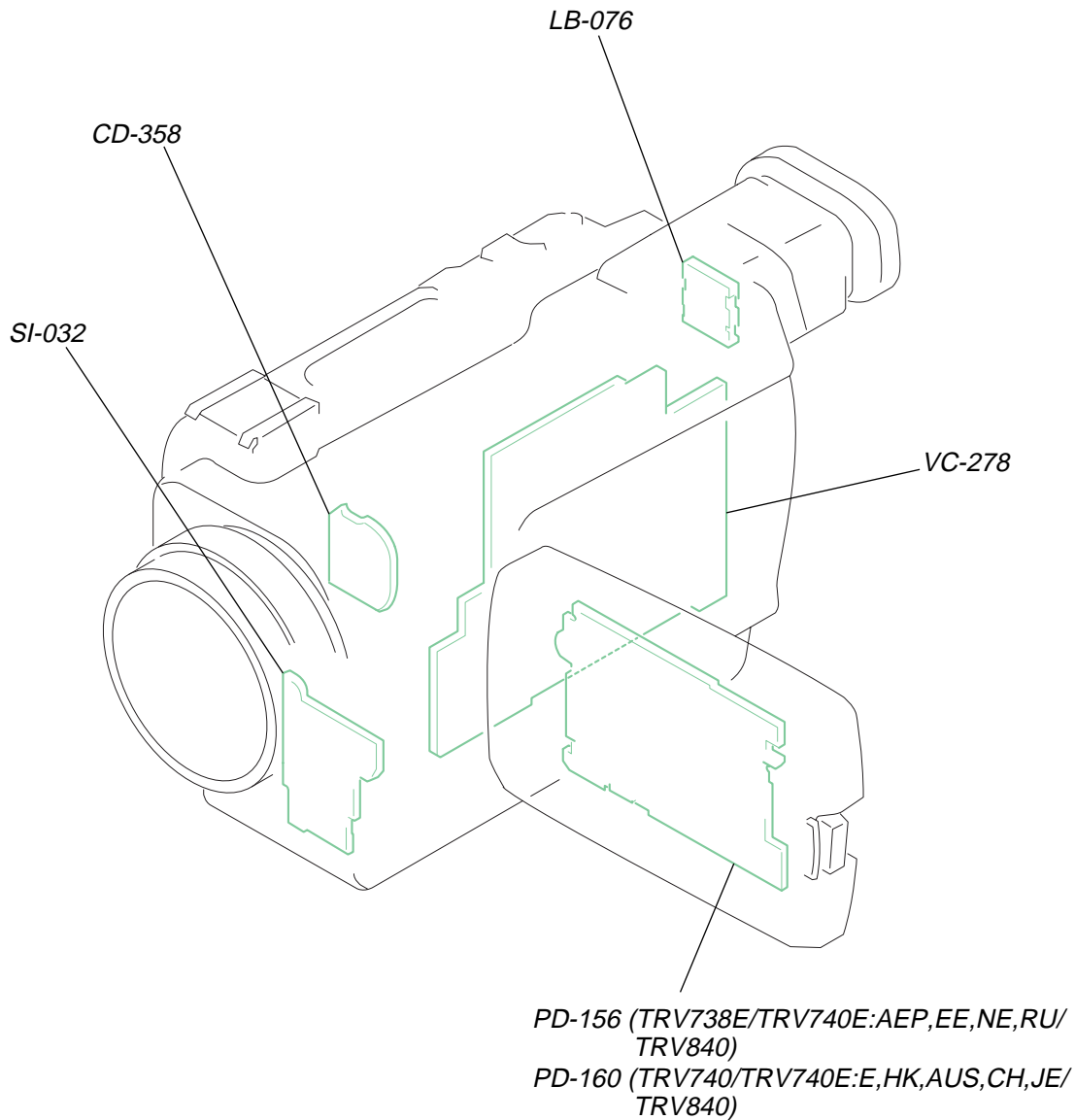

NAME	FUNCTION
CD-358	CCD IMAGER
LB-076	EVF BACK LIGHT
PD-156/160	CHA, DISPLAY DRIVE, BACK LIGHT/LCD DRIVE, TG
SI-032	STEADY SHOT, LASER LINK
VC-278	CAMERA, VIDEO, DV INTERFACE, CAMERA/MECHA/HI CONTROL, AUDIO, D/D CONVERTER

HK : Hong Kong model
 AUS : Australian model
 CH : Chinese model
 JE : Tourist model
 EE : East European model
 NE : North European model
 RU : Russian model



2-28. FLEXIBLE BOARDS LOCATION

The flexible boards contained in the mechanism deck and that in the lens device are not shown.

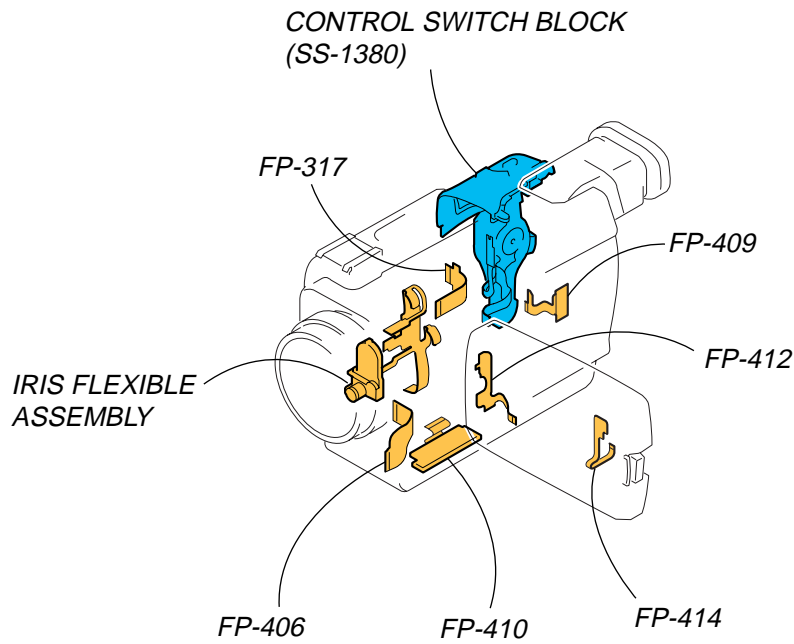
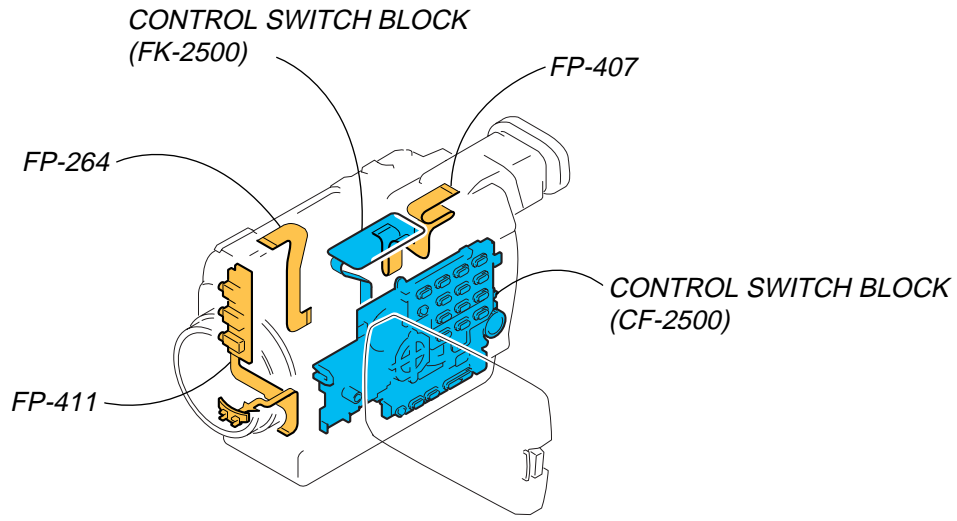



3. BLOCK DIAGRAMS

Link

OVERALL BLOCK DIAGRAM (1/6)	POWER BLOCK DIAGRAM (1/3)
OVERALL BLOCK DIAGRAM (2/6)	POWER BLOCK DIAGRAM (2/3)
OVERALL BLOCK DIAGRAM (3/6)	POWER BLOCK DIAGRAM (3/3)
OVERALL BLOCK DIAGRAM (4/6)	
OVERALL BLOCK DIAGRAM (5/6)	
OVERALL BLOCK DIAGRAM (6/6)	



SECTION 3
BLOCK DIAGRAMS

3. BLOCK DIAGRAMS

3-1. OVERALL BLOCK DIAGRAM (1/6) () : Number in parenthesis () indicates the division number of schematic diagram where the component is located.

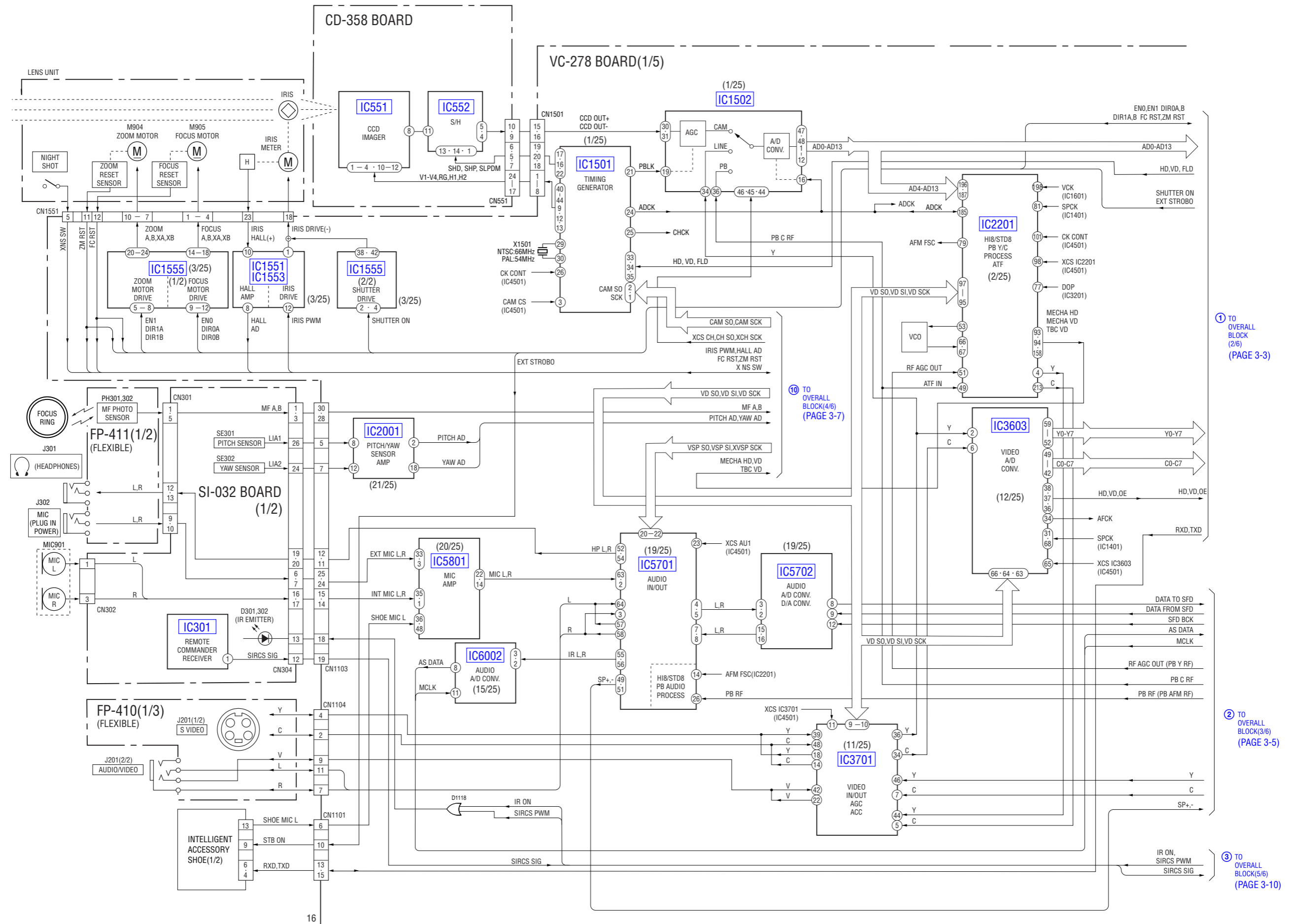

① TO OVERALL BLOCK (2/6) (PAGE 3-3)

⑩ TO OVERALL BLOCK (4/6) (PAGE 3-7)

② TO OVERALL BLOCK (3/6) (PAGE 3-5)

③ TO OVERALL BLOCK (5/6) (PAGE 3-10)

3. BLOCK DIAGRAMS

3-2. OVERALL BLOCK DIAGRAM (2/6) () : Number in parenthesis () indicates the division number of schematic diagram where the component is located.

VC-278 BOARD(2/6)

① TO OVERALL BLOCK (1/6) (PAGE 3-2)

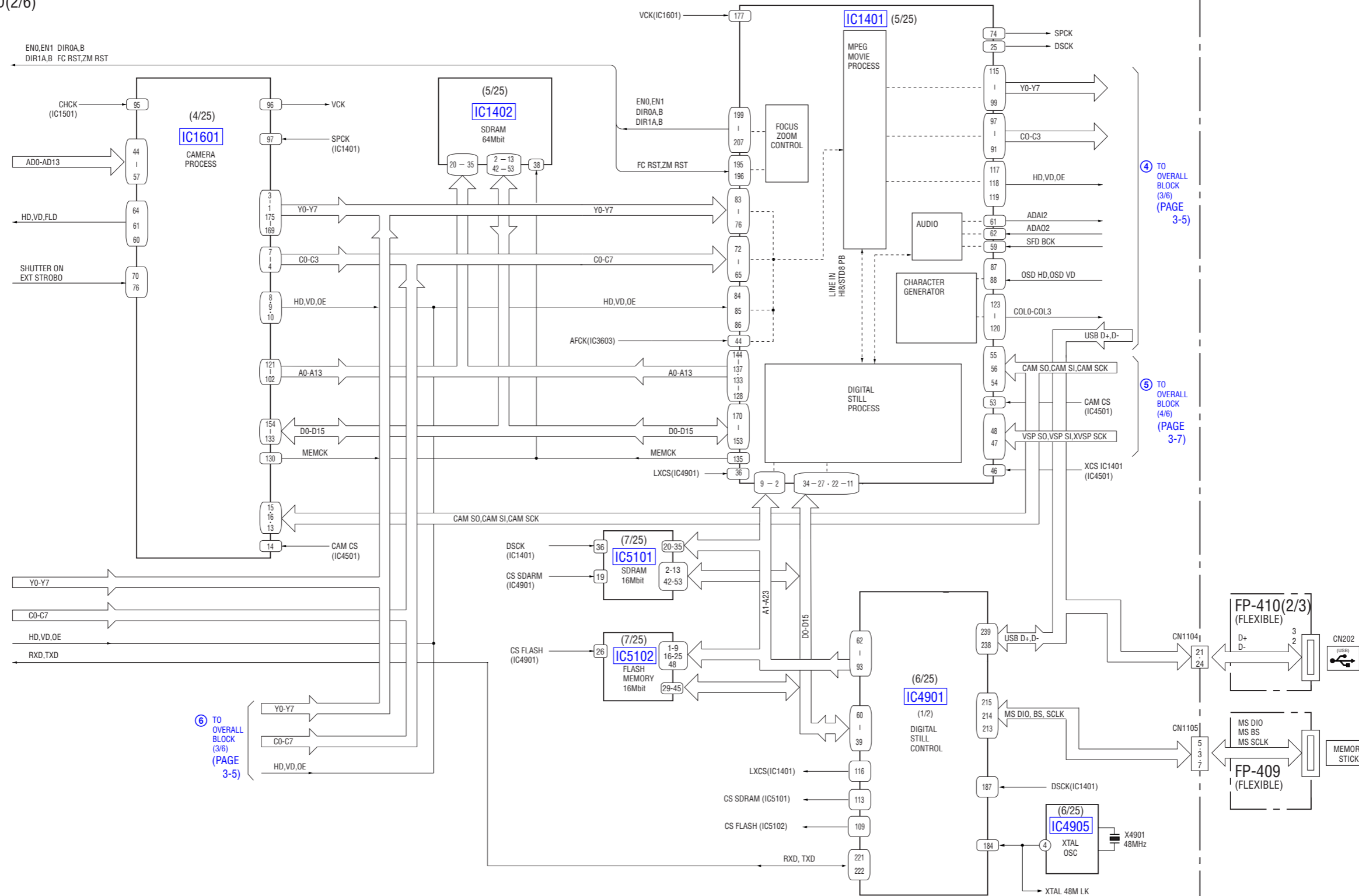

④ TO OVERALL BLOCK (3/6) (PAGE 3-5)

⑤ TO OVERALL BLOCK (4/6) (PAGE 3-7)

⑥ TO OVERALL BLOCK (3/6) (PAGE 3-5)



3. BLOCK DIAGRAMS

3-3. OVERALL BLOCK DIAGRAM (3/6) () : Number in parenthesis () indicates the division number of schematic diagram where the component is located.

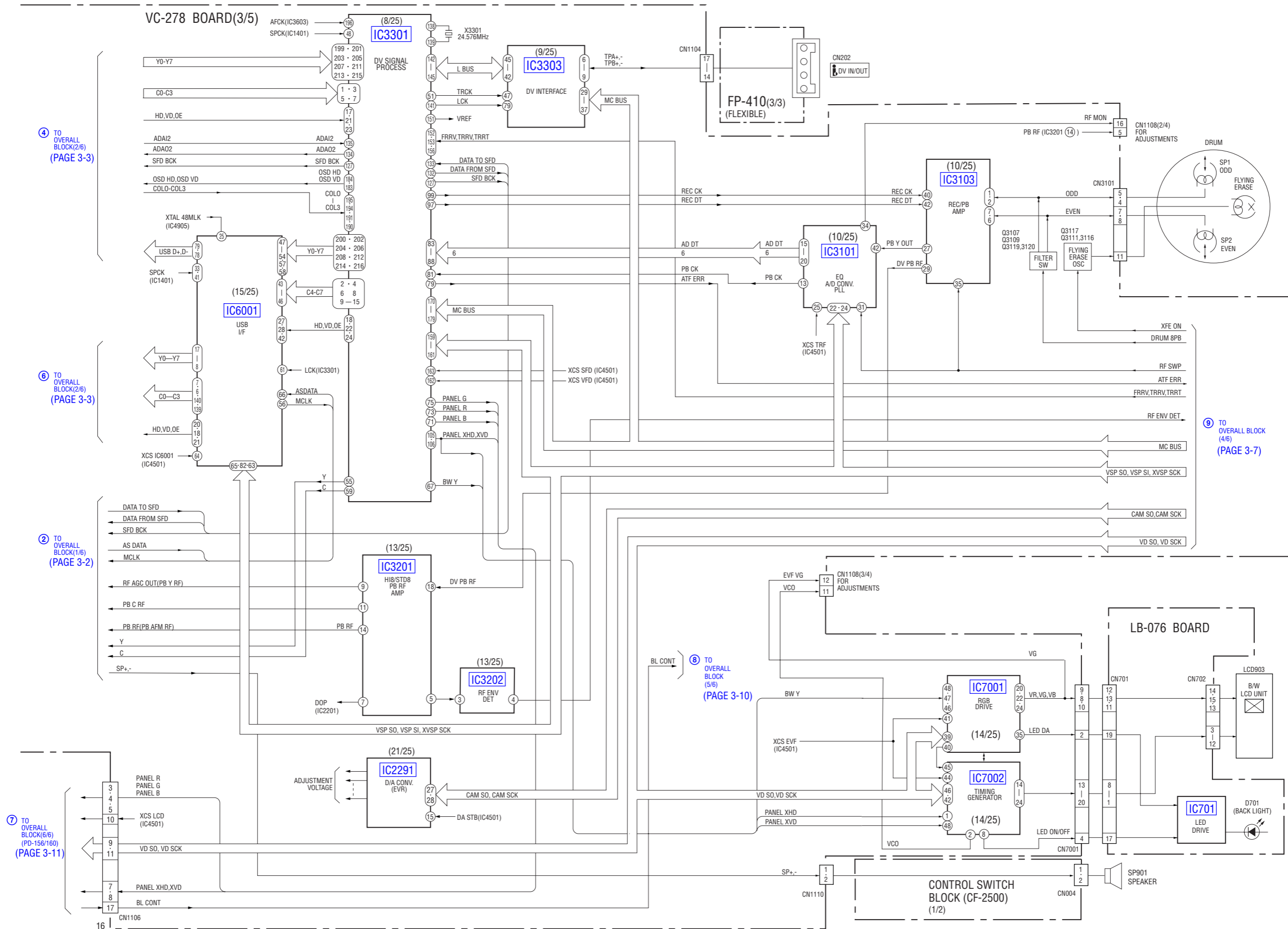

4 TO OVERALL BLOCK(2/6) (PAGE 3-3)

6 TO OVERALL BLOCK(2/6) (PAGE 3-3)

2 TO OVERALL BLOCK(1/6) (PAGE 3-2)

7 TO OVERALL BLOCK(6/6) (PD-156/160) (PAGE 3-11)

9 TO OVERALL BLOCK(4/6) (PAGE 3-7)

8 TO OVERALL BLOCK(5/6) (PAGE 3-10)



3. BLOCK DIAGRAMS

3-4. OVERALL BLOCK DIAGRAM (4/6) () : Number in parenthesis () indicates the division number of schematic diagram where the component is located.

VC-278 BOARD(4/5)

M2000 MECHA DECK

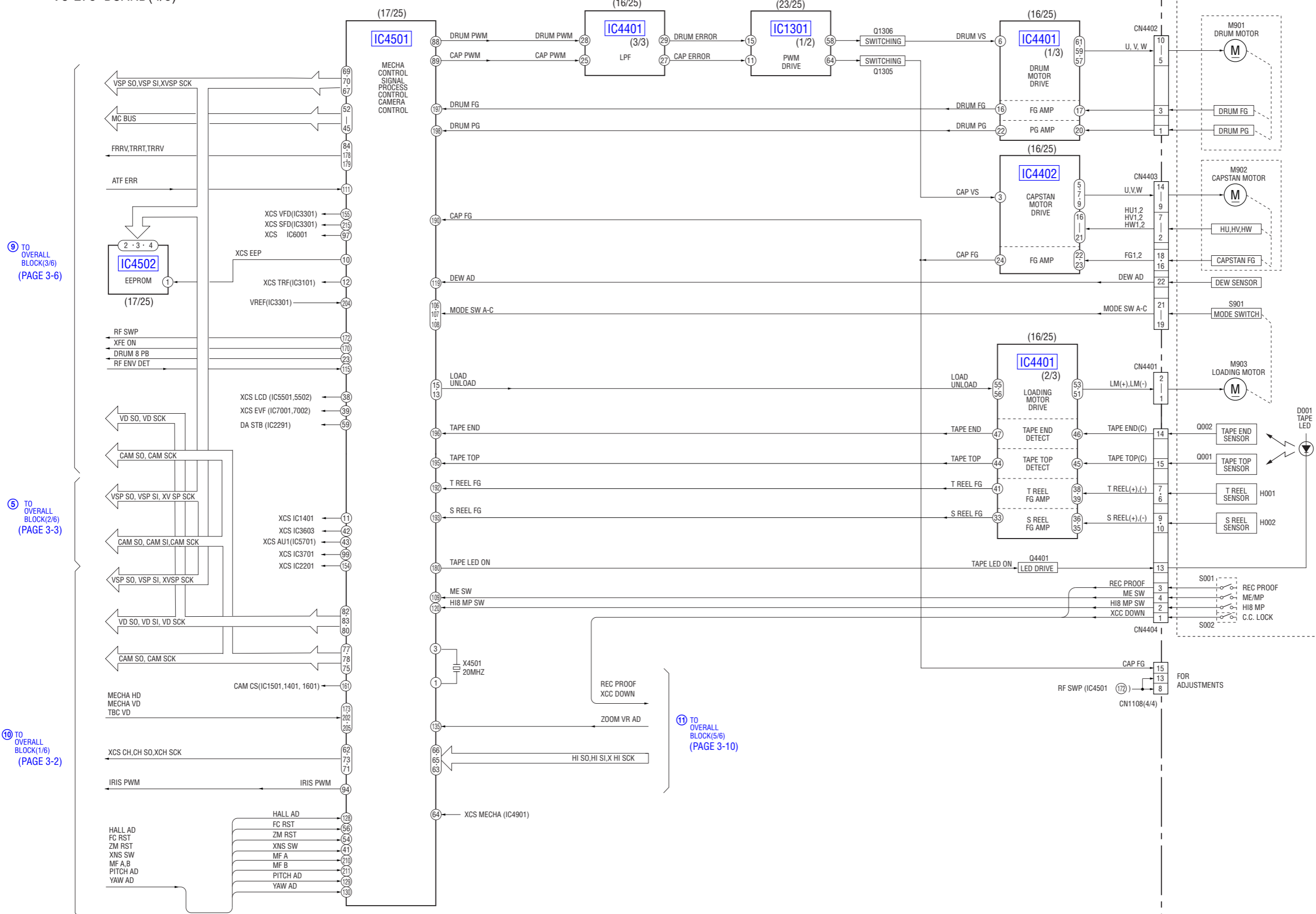

⑨ TO OVERALL BLOCK(3/6) (PAGE 3-6)

⑤ TO OVERALL BLOCK(2/6) (PAGE 3-3)

⑩ TO OVERALL BLOCK(1/6) (PAGE 3-2)

⑪ TO OVERALL BLOCK(5/6) (PAGE 3-10)



3. BLOCK DIAGRAMS

3-5. OVERALL BLOCK DIAGRAM (5/6) (): Number in parenthesis () indicates the division number of schematic diagram where the component is located.

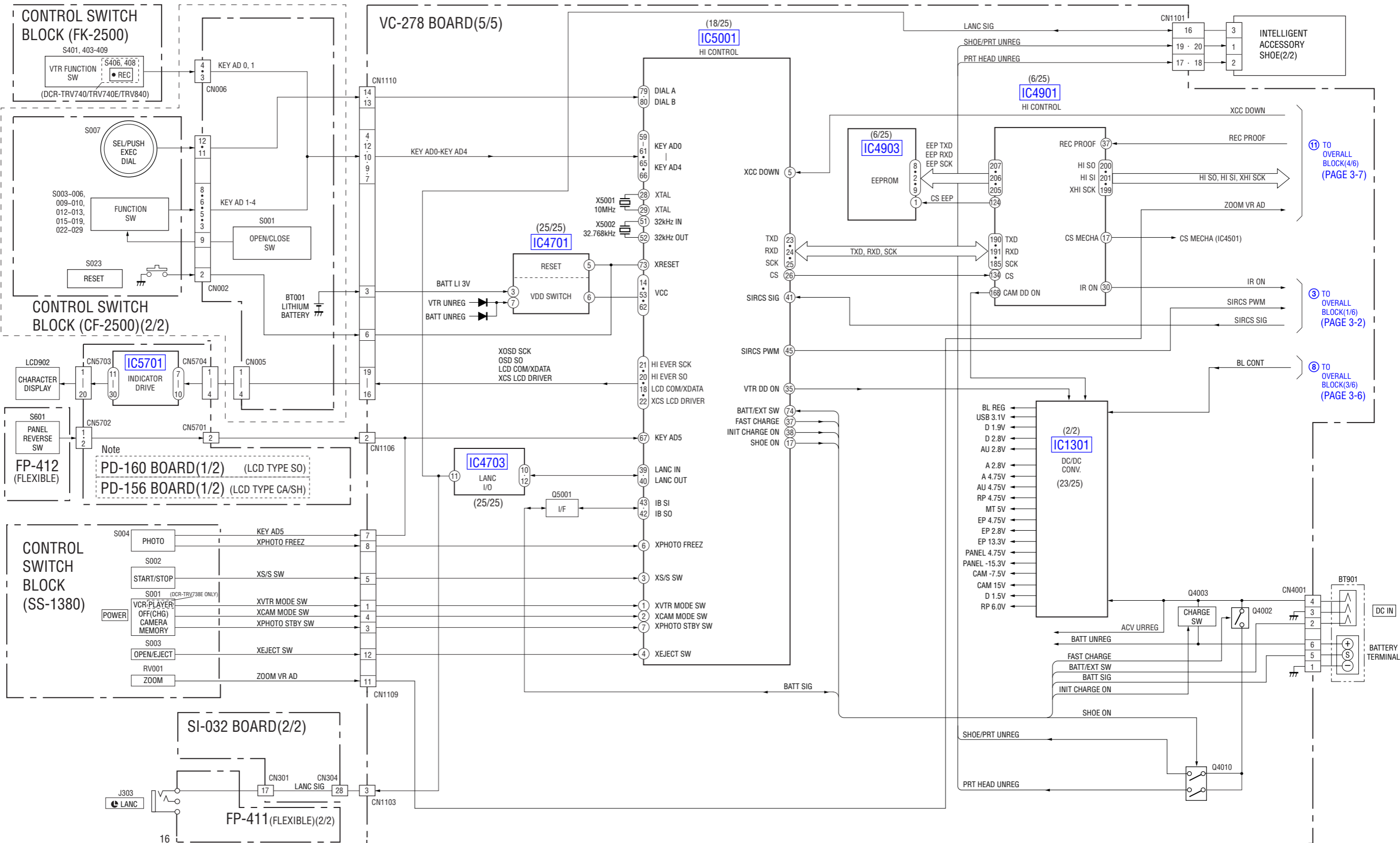

Note: Refer to "3-6. OVERALL BLOCK DIAGRAM (6/6)" for the discrimination of the LCD type.

3-6. OVERALL BLOCK DIAGRAM (6/6) () : Number in parenthesis () indicates the division number of schematic diagram where the component is located.

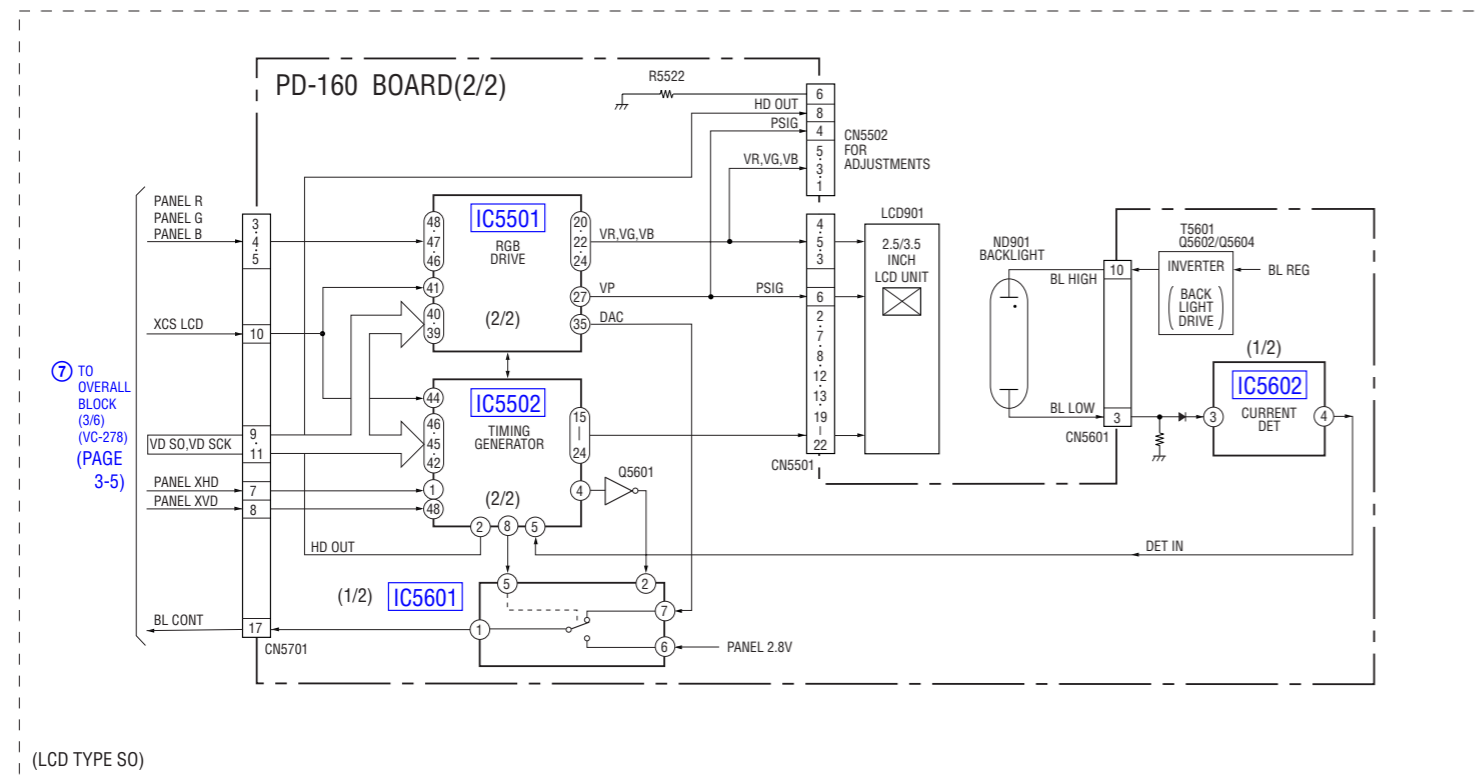
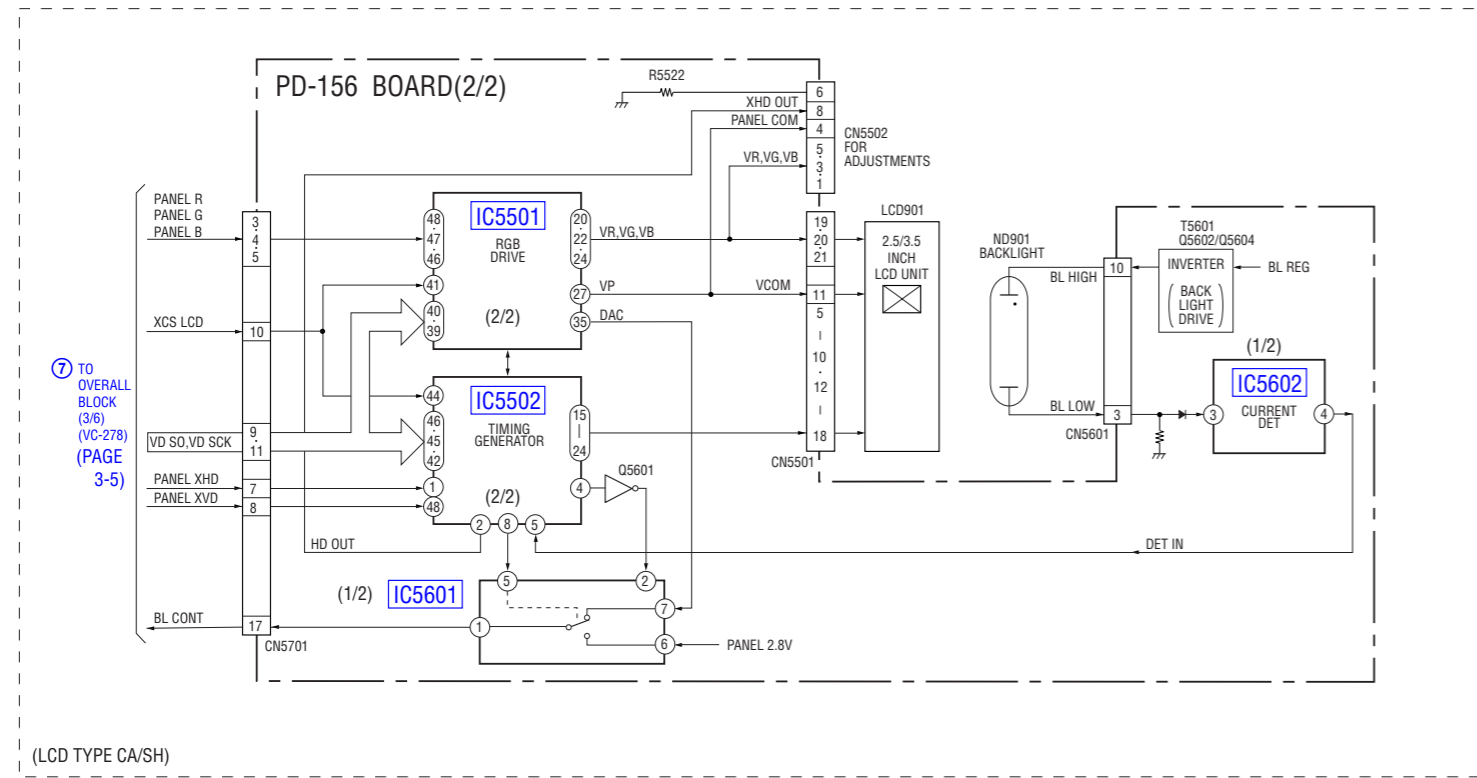

Note: By measuring the resistor value between Pin ⑥ of CN5502 on PD-156/160 board and GND, the type of LCD can be discriminated.
 2.2kΩ: LCD TYPE SH (2.5 inches, 123k) DCR-TRV738E/TRV740E (*1)
 6.8kΩ: LCD TYPE CA (3.5 inches, 123k) DCR-TRV840
 22kΩ: LCD TYPE SO (2.5 inches, 61k) DCR-TRV740/TRV740E (*2)
 47kΩ: LCD TYPE SO (3.5 inches, 123k) DCR-TRV840
 *1: AEP/EE/NE/RU model, *2: E/AUS/HK/CH/JE model

- Abbreviation
- EE : East European model
- NE : North European model
- RU : Russian model
- AUS : Australian model
- HK : Hong Kong model
- CH : Chinese model
- JE : Tourist model



3. BLOCK DIAGRAMS

3-7. POWER BLOCK DIAGRAM (1/3) () : Number in parenthesis () indicates the division number of schematic diagram where the component is located.

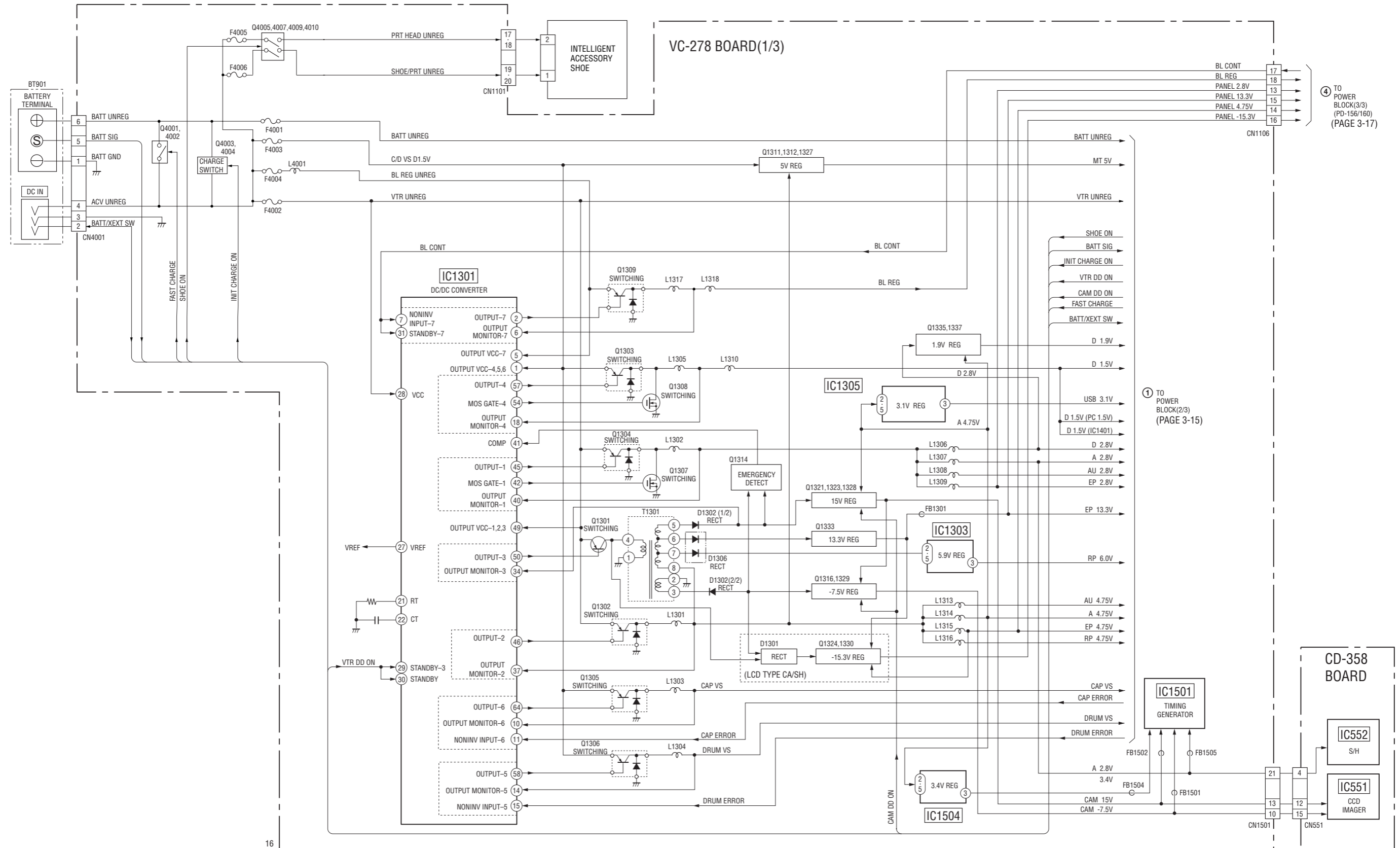

Note: Refer to "3-6. OVERALL BLOCK DIAGRAM (6/6)" for the discrimination of the LCD type.



3. BLOCK DIAGRAMS

3-8. POWER BLOCK DIAGRAM (2/3) () : Number in parenthesis () indicates the division number of schematic diagram where the component is located.

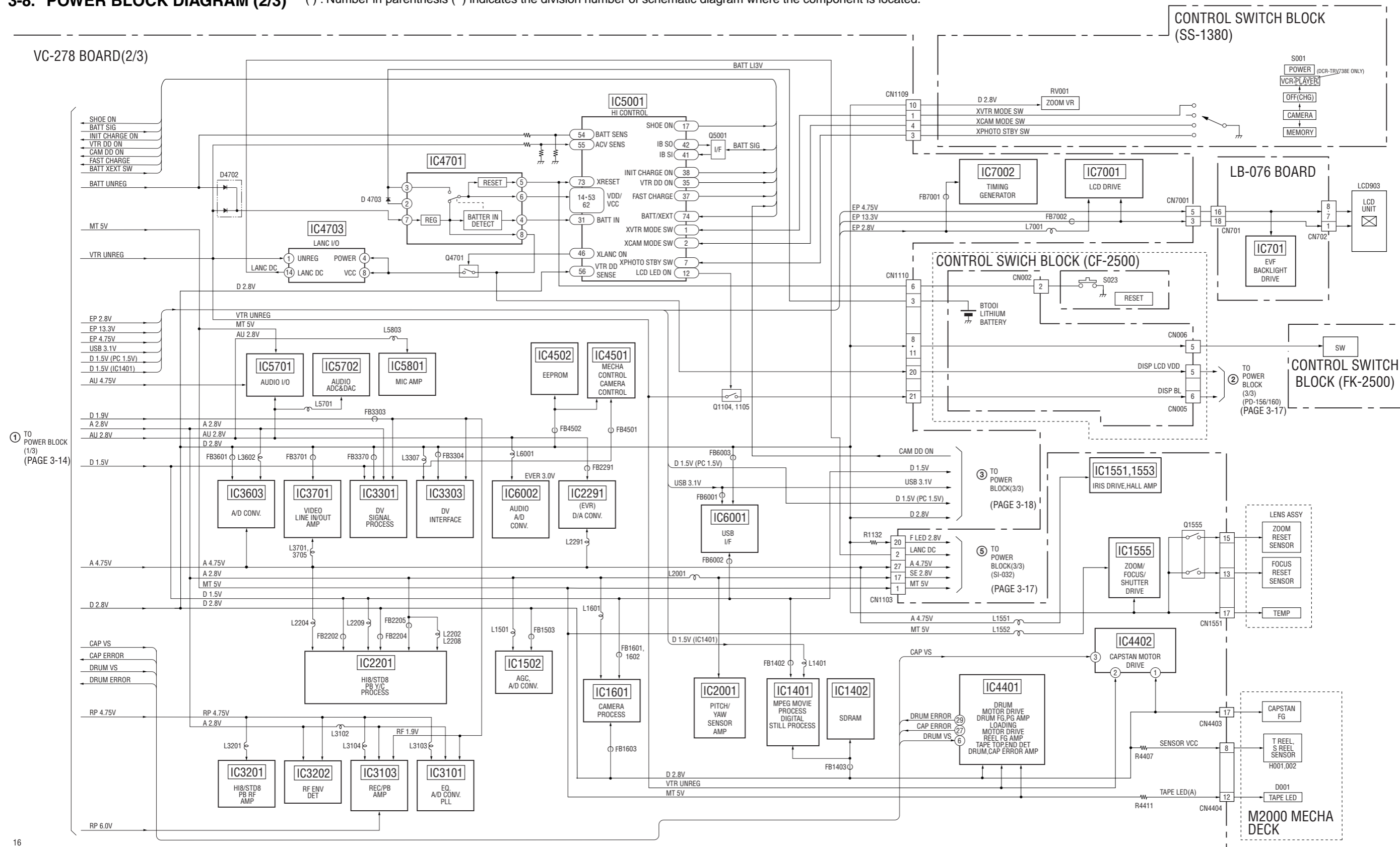

① TO POWER BLOCK (1/3) (PAGE 3-14)

③ TO POWER BLOCK(3/3) (PAGE 3-18)

⑤ TO POWER BLOCK(3/3) (SI-032) (PAGE 3-17)

② TO POWER BLOCK (3/3) (PD-156/160) (PAGE 3-17)



3. BLOCK DIAGRAMS

3-9. POWER BLOCK DIAGRAM (3/3) () : Number in parenthesis () indicates the division number of schematic diagram where the component is located.

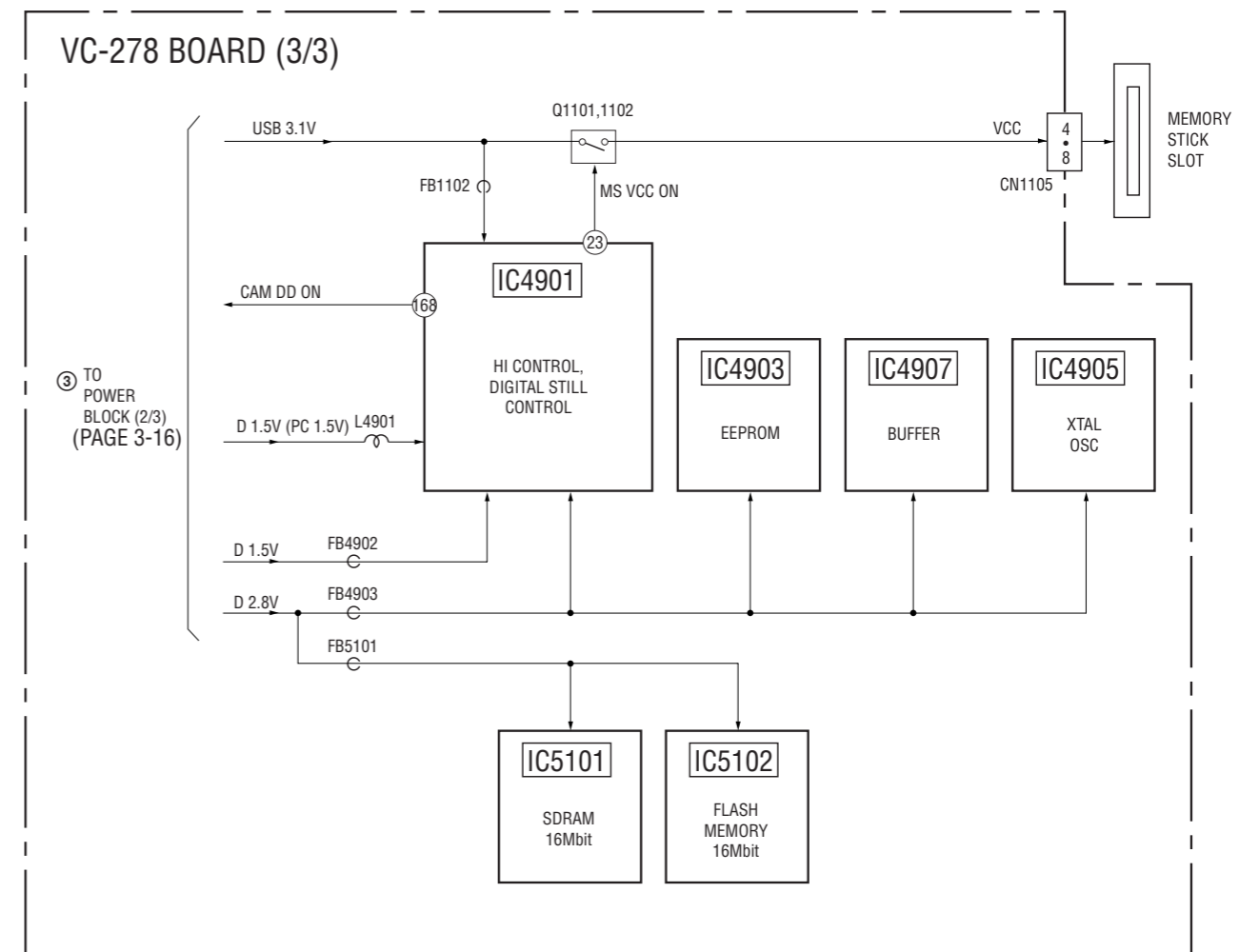
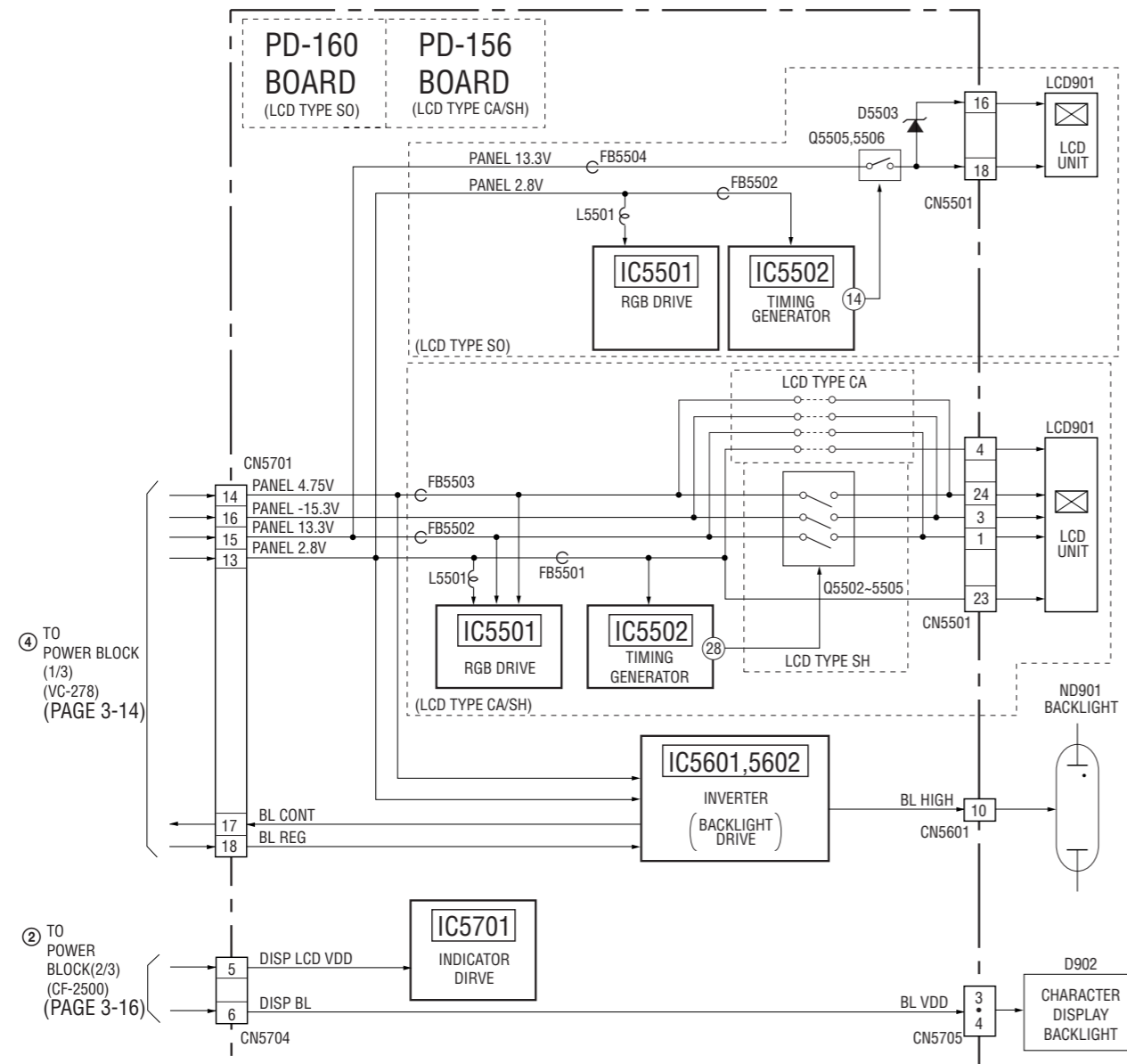

Note: Refer to "3-6. OVERALL BLOCK DIAGRAM (6/6)" for the discrimination of the LCD type.

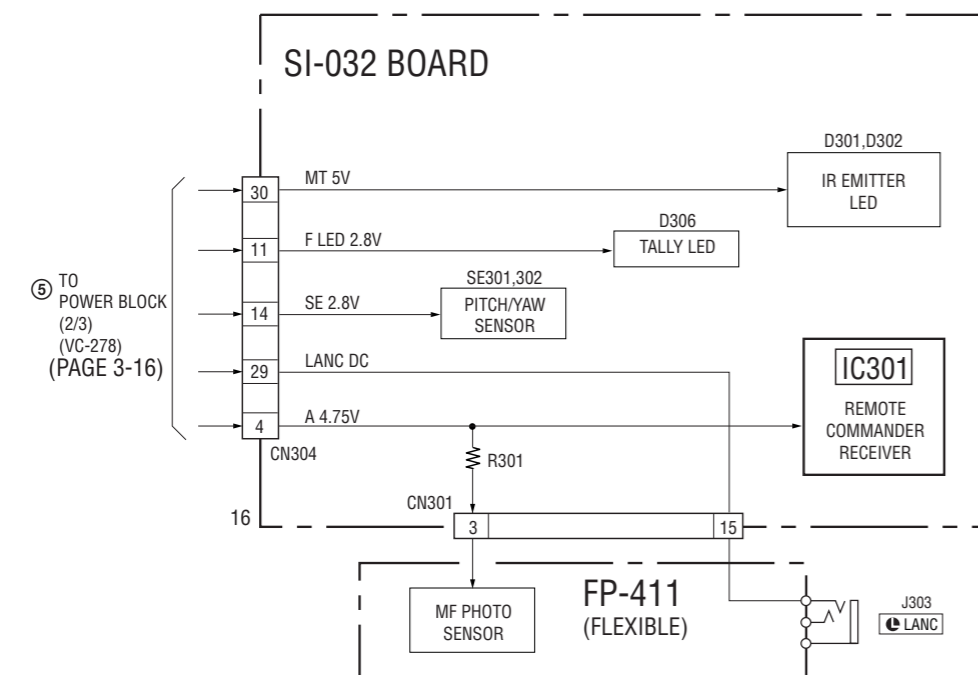



SECTION 4

PRINTED WIRING BOARDS AND SCHEMATIC DIAGRAMS

4-1. FRAME SCHEMATIC DIAGRAM (1/2)

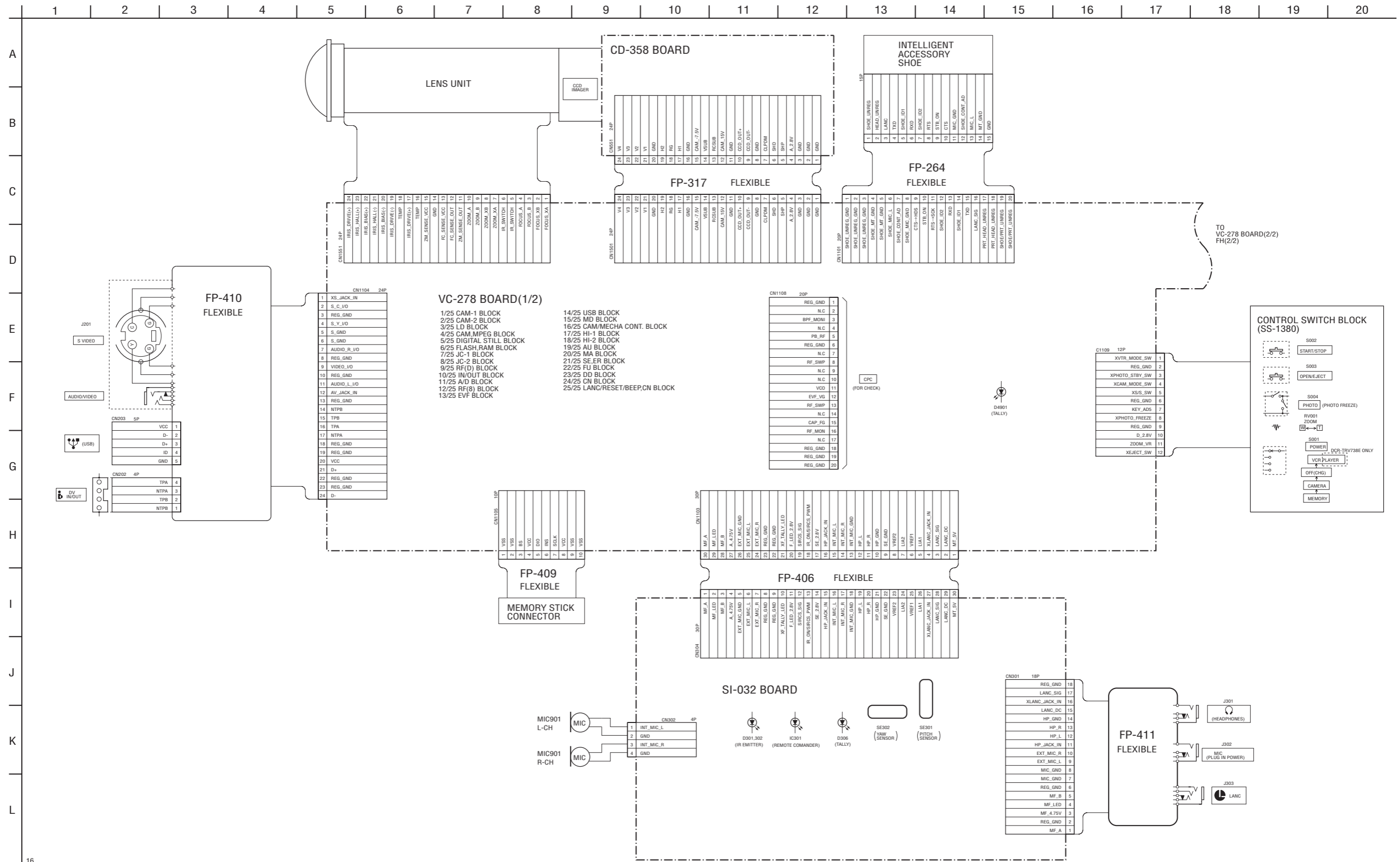



4-2. SCHEMATIC DIAGRAMS

4-3. PRINTED WIRING BOARDS

FRAME SCHEMATIC DIAGRAM (2/2)

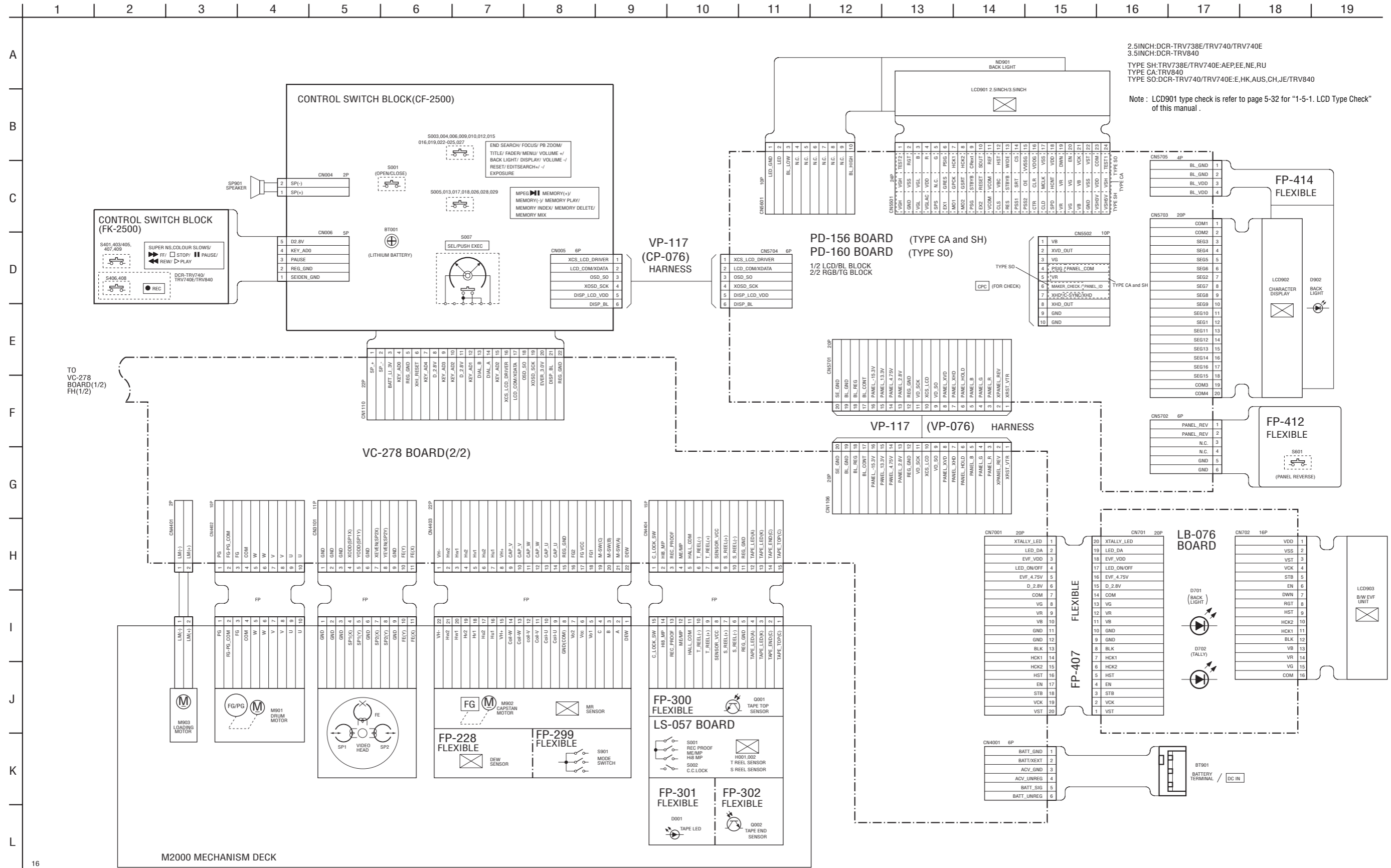

2.5INCH:DCR-TRV738E/TRV740/TRV740E
 3.5INCH:DCR-TRV840
 TYPE SH:TRV738E/TRV740E:AEP,EE,NE,RU
 TYPE CA:TRV840
 TYPE SO:DCR-TRV740/TRV740E:E,HK,AUS,CH,JE/TRV840

Note : LCD901 type check is refer to page 5-32 for "1-5-1. LCD Type Check" of this manual .



THIS NOTE IS COMMON FOR WIRING BOARDS AND SCHEMATIC DIAGRAMS
(In addition to this, the necessary note is printed in each block)

(For printed wiring boards)

- Pattern from the side which enables seeing.
(The other layers' patterns are not indicated.)
- Through hole is omitted.
- Circled numbers refer to waveforms.
- There are few cases that the part printed on diagram isn't mounted in this model.
- Chip parts.

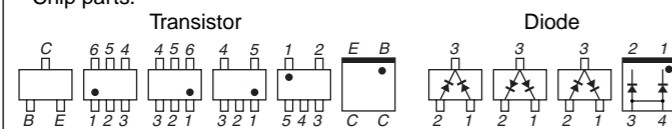

(For schematic diagrams)

- All capacitors are in μF unless otherwise noted. p: pF. 50V or less are not indicated except for electrolytics and tantalums.
- Chip resistors are 1/10W unless otherwise noted. $\text{k}\Omega=1000\Omega$, $\text{M}\Omega=1000\text{k}\Omega$.
- Caution when replacing chip parts.
New parts must be attached after removal of chip.
Be careful not to heat the minus side of tantalum capacitor, because it is damaged by the heat.
- Some chip part will be indicated as follows.

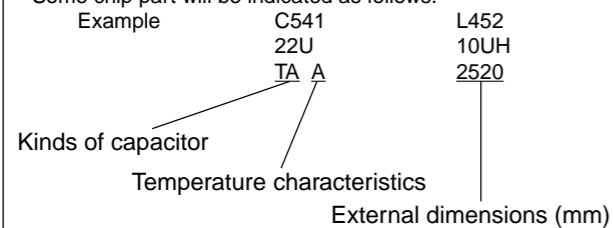

- Constants of resistors, capacitors, ICs and etc with XX indicate that they are not used.
In such cases, the unused circuits may be indicated.
 - All variable and adjustable resistors have characteristic curve B, unless otherwise noted.
 - Signal name
XEDIT → EDIT PB/XREC → PB/REC
 - non flammable resistor
 - fusible resistor
 - panel designation
 - B+ Line *
 - B- Line *
 - IN/OUT direction of (+,-) B LINE. *
 - adjustment for repair. *
 - Circled numbers refer to waveforms. *
- * Indicated by the color red.

Note :
The components identified by mark Δ or dotted line with mark Δ are critical for safety. Replace only with part number specified.

Note :
Les composants identifiés par une marque Δ sont critiques pour la sécurité. Ne les remplacer que par une pièce portant le numéro spécifié.

(Measuring conditions voltage and waveform)

- Voltages and waveforms are measured between the measurement points and ground when camera shoots color bar chart of pattern box. They are reference values and reference waveforms. *
- (VOM of DC 10 $\text{M}\Omega$ input impedance is used.).
- Voltage values change depending upon input impedance of VOM used.) *

1. Connection

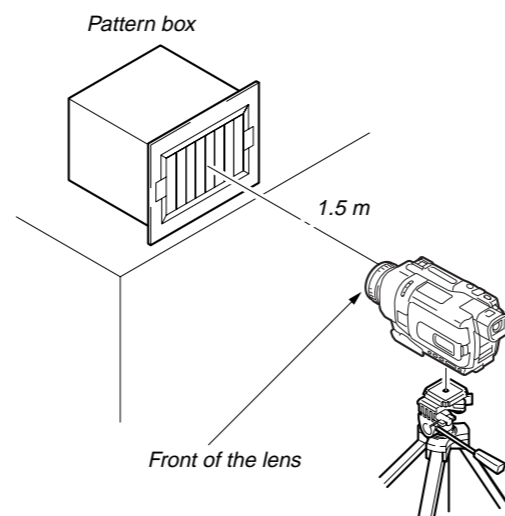

2. Adjust the distance so that the output waveform of Fig. a and the Fig. b can be obtain.

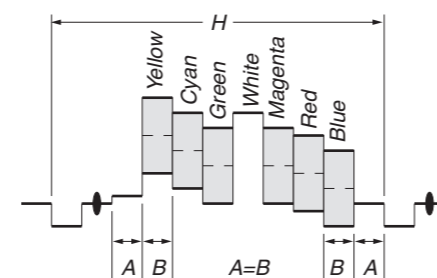

Fig. a (Video output terminal output waveform)

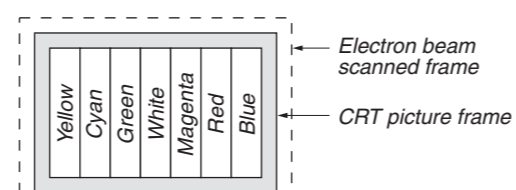

Fig. b (Picture on monitor TV)

When indicating parts by reference number, please include the board name.



4-2. SCHEMATIC DIAGRAMS

Link

• CD-358 BOARD (CCD IMAGER)	
• LB-076 BOARD (EVF, BACK LIGHT)	
• SI-032 BOARD (STEADY SHOT, LASER LINK)	
• CONTROL SWITCH BLOCK (CF-2500)	
• PD-156 BOARD (1/2) (CHA, DISPLAY DRIVE, BACK LIGHT)	
• PD-156 BOARD (2/2) (LCD DRIVE, TG)	
• PD-160 BOARD (1/2) (CHA, DISPLAY DRIVE, BACK LIGHT)	
• PD-160 BOARD (2/2) (LCD DRIVE, TG)	
• LS-057, FP-228, FP-299, FP-300, FP-302, FP-301 FLEXIBLE BOARDS	
• FP-410 FLEXIBLE BOARD (AV TERMINAL)	
• CONTROL SWITCH BLOCK (SS-1380)	

• COMMON NOTE FOR SCHEMATIC DIAGRAMS

• WAVEFORMS



4-2. SCHEMATIC DIAGRAMS CD-358 BOARD LB-076 BOARD

4-2. SCHEMATIC DIAGRAMS

For Schematic Diagram
 • Refer to page 4-73 for printed wiring board.
 • Refer to page 4-91 for waveforms.

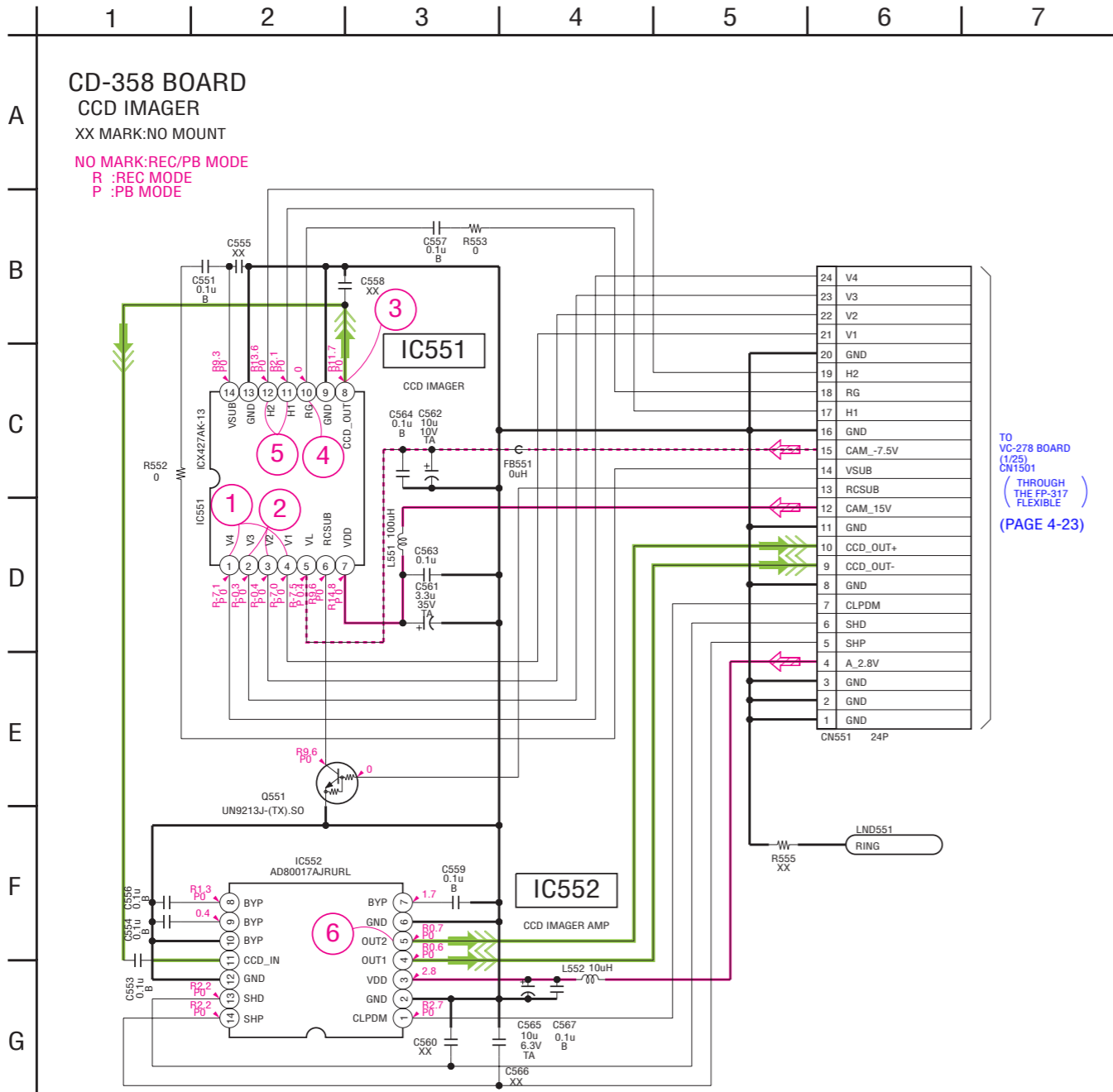

Precautions Upon Replacing CCD imager

- The CD-358 board mounted as a repair part is not equipped with a CCD imager. When replacing this board, remove the CCD imager from the old one and mount it onto the new one.
- If the CCD imager has been replaced, carry out all the adjustments for the camera section.
- As the CCD imager may be damaged by static electricity from its structure, handle it carefully like for the MOS IC. In addition, ensure that the receiver is not covered with dusts nor exposed to strong light.

SIGNAL PATH

	VIDEO SIGNAL		
	CHROMA	Y	Y/CHROMA
REC		→	
PB		→	

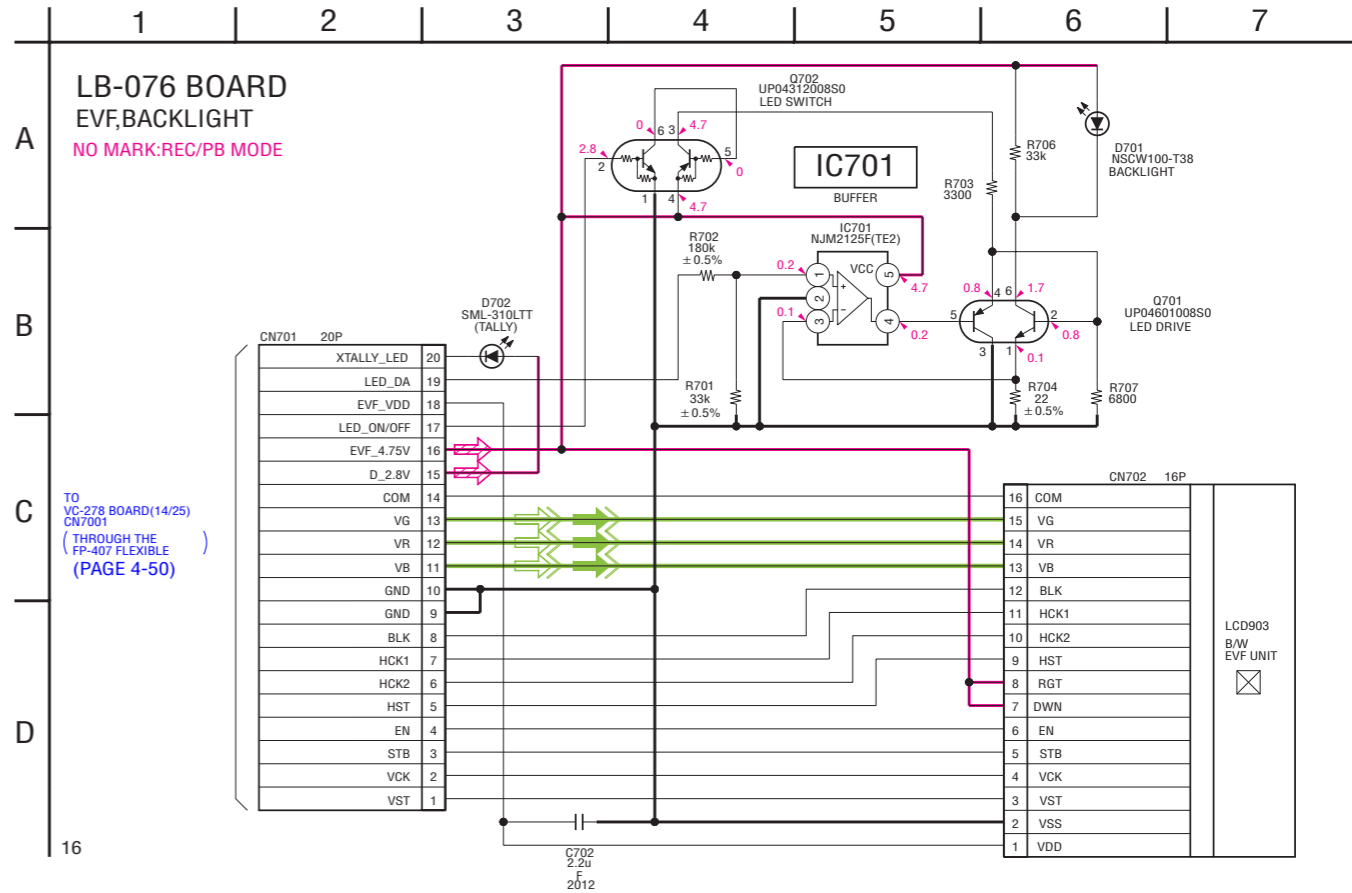

SIGNAL PATH

	VIDEO SIGNAL		
	CHROMA	Y	Y/CHROMA
REC		→	
PB		→	



For Schematic Diagram
 • Refer to page 4-75 for printed wiring board.

1 2 3 4 5 6 7 8 9 10 11 12 13 14

A
B
C
D
E
F
G
H
I

SI-032 BOARD
 STEADY SHOT, LASER LINK
 NO MARK: REC/PB MODE

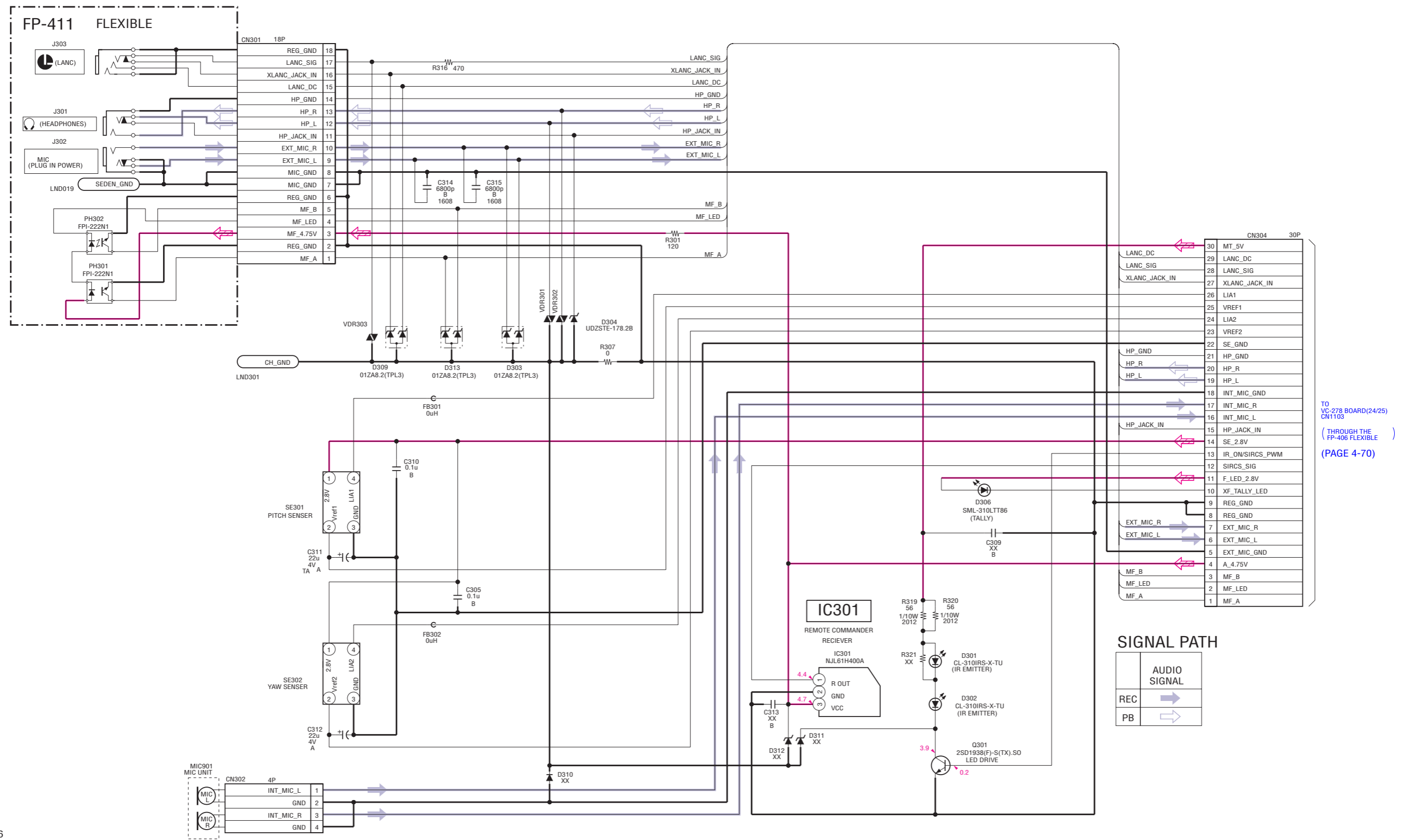

TO VC-278 BOARD(24/25) CN1103
 (THROUGH THE FP-406 FLEXIBLE)
 (PAGE 4-70)

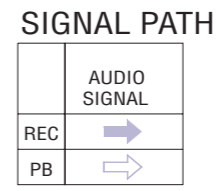

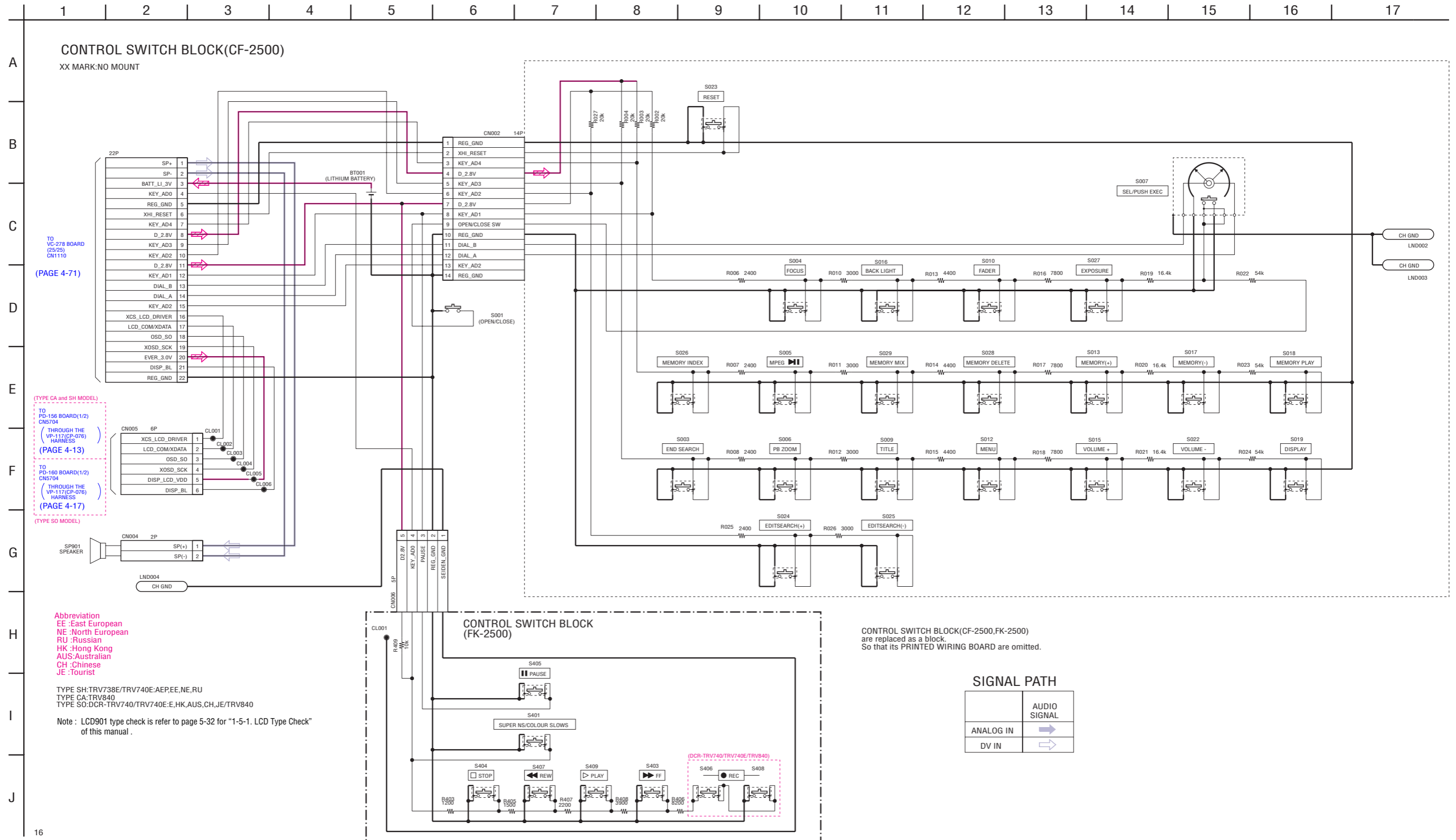



For Schematic Diagram

- Refer to page 4-79 for printed wiring board.
- Refer to page 4-91 for waveforms.

1 2 3 4 5 6 7 8 9 10 11 12 13 14

A PD-156 BOARD(1/2) (TYPE CA and SH MODEL)
B LCD DRIVER, BACK LIGHT(BL/LCD BLOCK)
 XX MARK:NO MOUNT

TYPE SH :TRV738E/TRV740E:AEP,EE,NE,RU
 TYPE CA :TRV840

LCD Type Check
 By measuring resistor value between pin ⑧ and pin ⑩ (GND) of CN5502, the type of LCD can be discriminated.
 2.2k:LCD type SH
 6.8k:LCD type CA

Abbreviation
 EE:East European
 NE:North European
 RU:Russian

Note :
 The components identified by mark Δ or dotted line with mark Δ are critical for safety. Replace only with part number specified.

Note :
 Les composants identifiés par une marque Δ sont critiques pour la sécurité. Ne les remplacer que par une pièce portant le numéro spécifié.

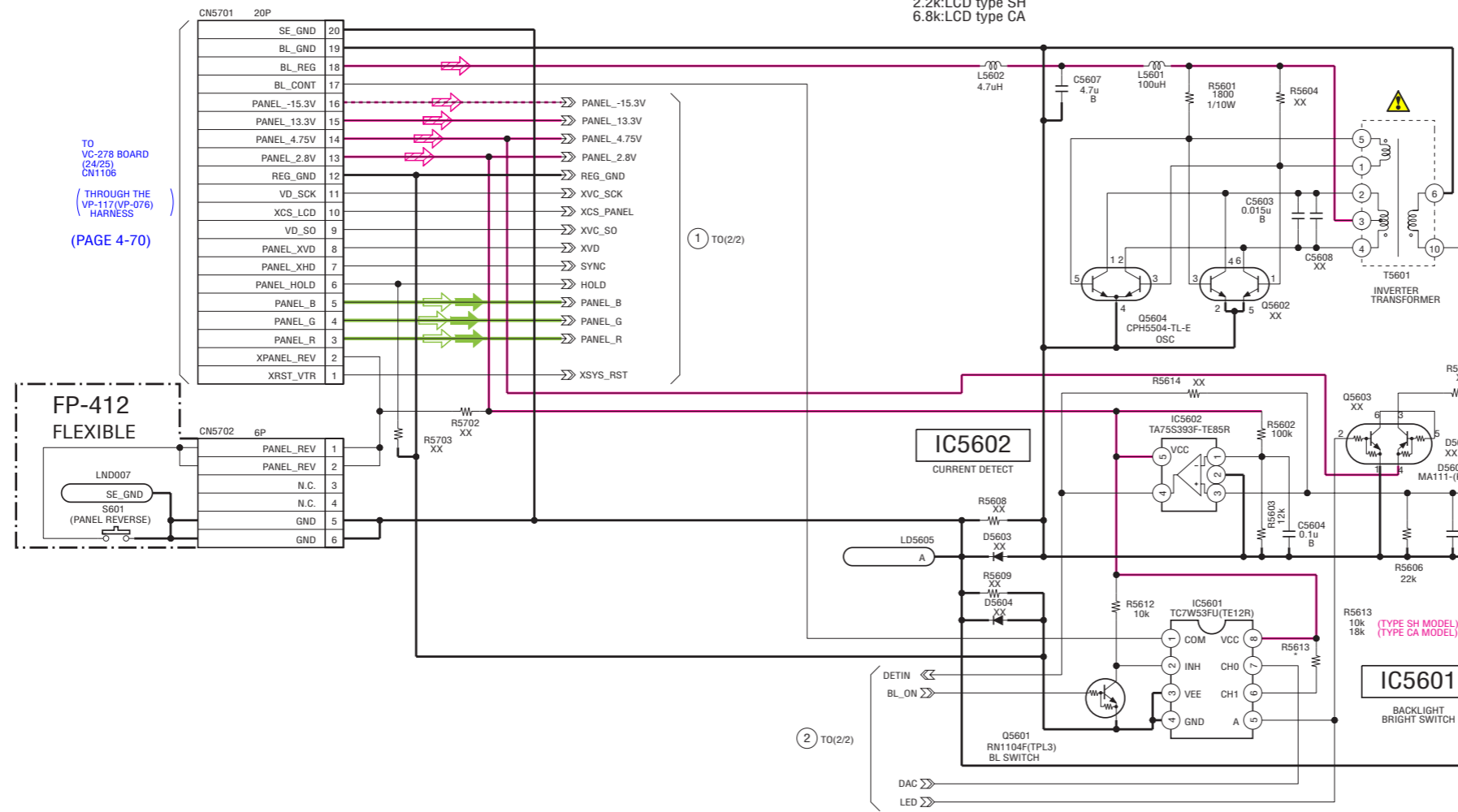

SIGNAL PATH

	VIDEO SIGNAL		
	CHROMA	Y	Y/CHROMA
ANALOG IN	→		
DV IN	→		

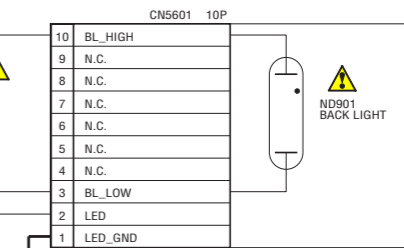

FP-414 FLEXIBLE is replaced as a block. So that this PRINTED WIRING BOARD is omitted.

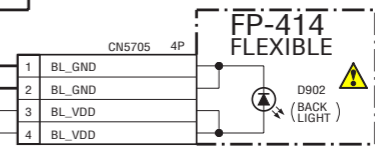

TO VC-278 BOARD (24/25) CN1106
 (THROUGH THE VP-117(VP-076) HARNESS)
 (PAGE 4-70)

TO CONTROL SWITCH BLOCK (CP-2500) CN005
 (THROUGH THE VP-117(CP-076) HARNESS)
 (PAGE 4-11)

A
B
C
D
E
F
G
H
I
J



4-2. SCHEMATIC DIAGRAMS

PD-156 BOARD SIDE A

PD-156 BOARD SIDE B

For Schematic Diagram

- Refer to page 4-79 for printed wiring board.
- Refer to page 4-91 for waveforms.

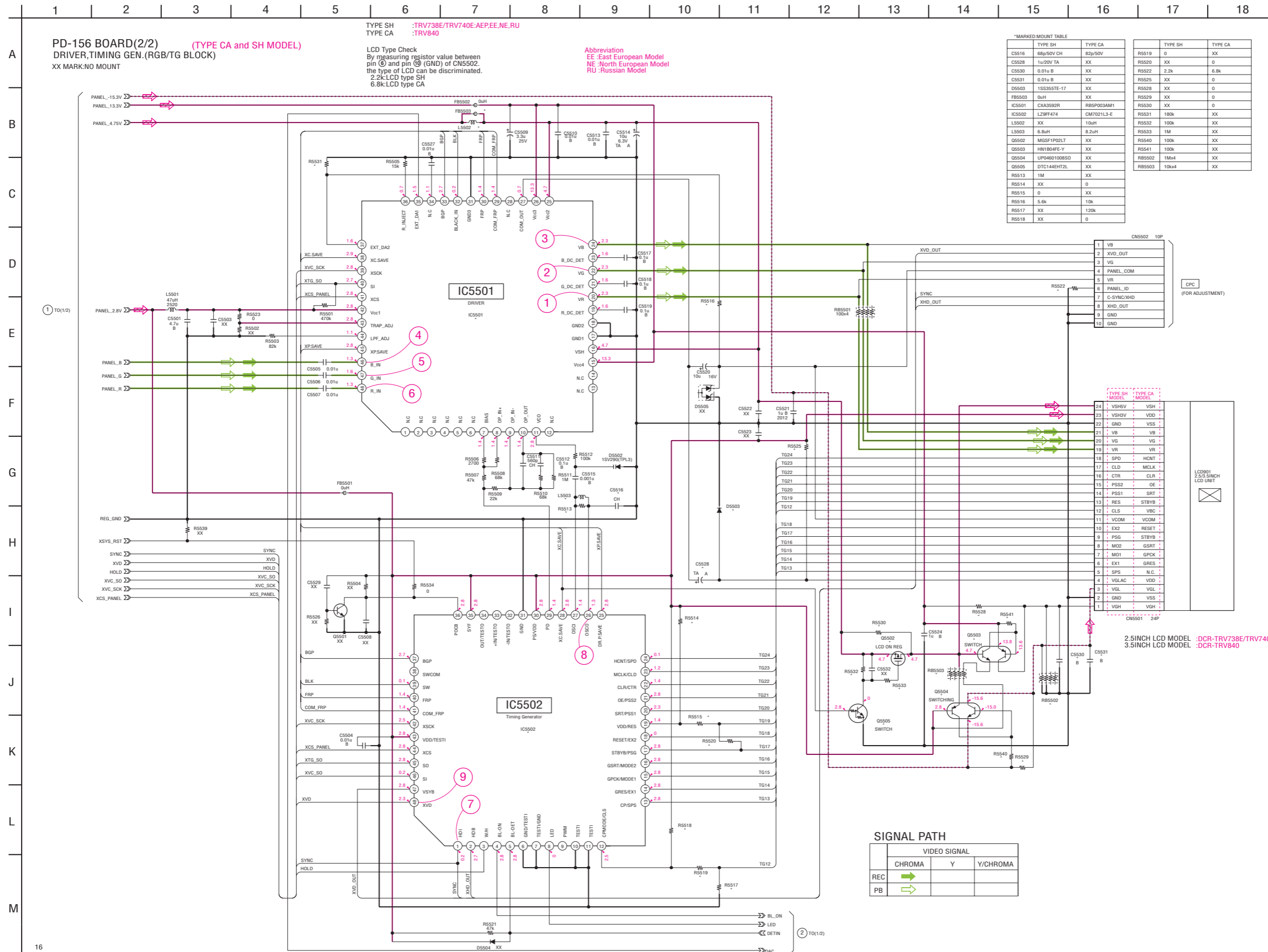



For Schematic Diagram

- Refer to page 4-83 for printed wiring board.
- Refer to page 4-92 for waveforms.

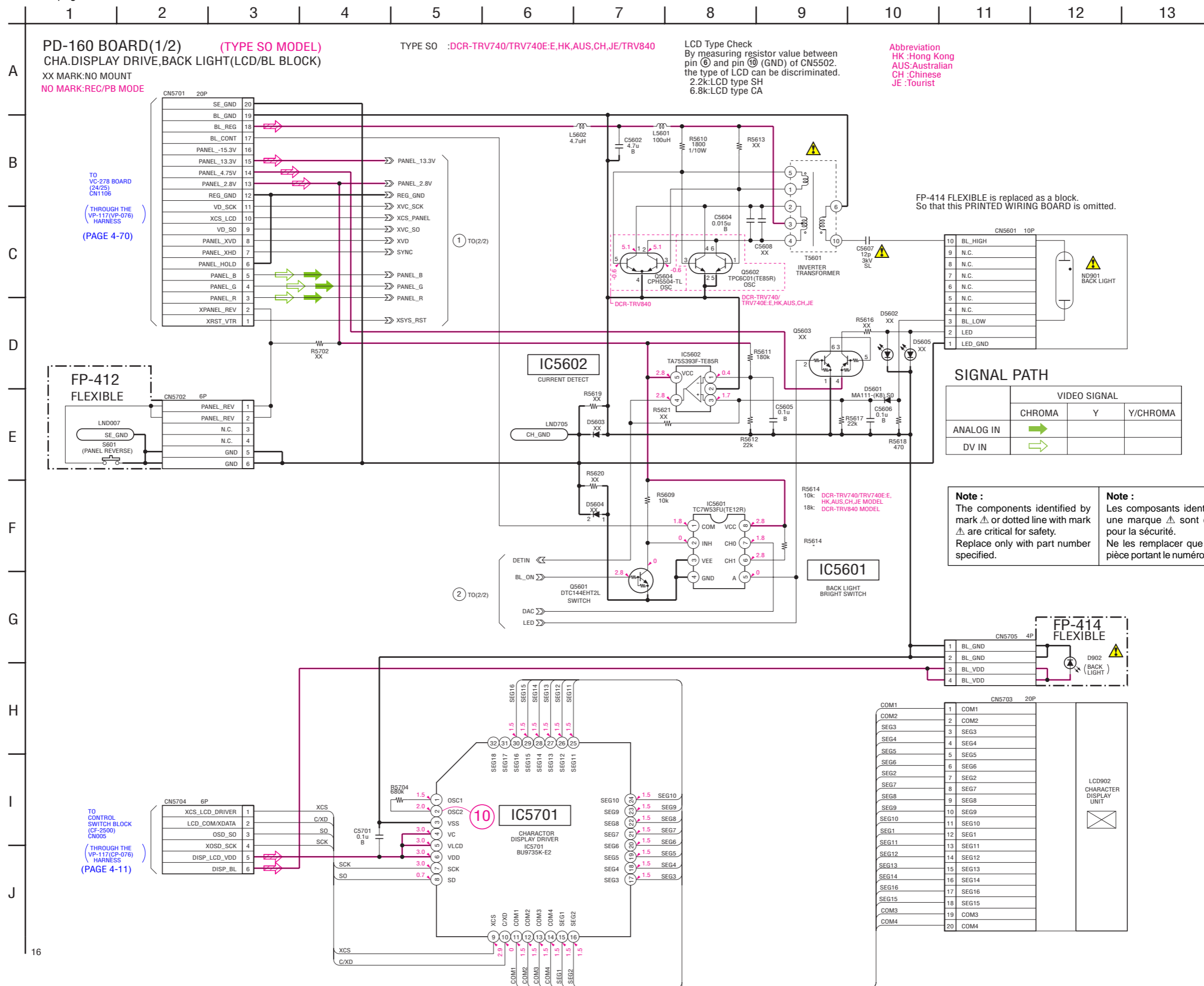



4-2. SCHEMATIC DIAGRAMS

PD-160 BOARD SIDE A

PD-160 BOARD SIDE B

For Schematic Diagram

- Refer to page 4-83 for printed wiring board.
- Refer to page 4-92 for waveforms.

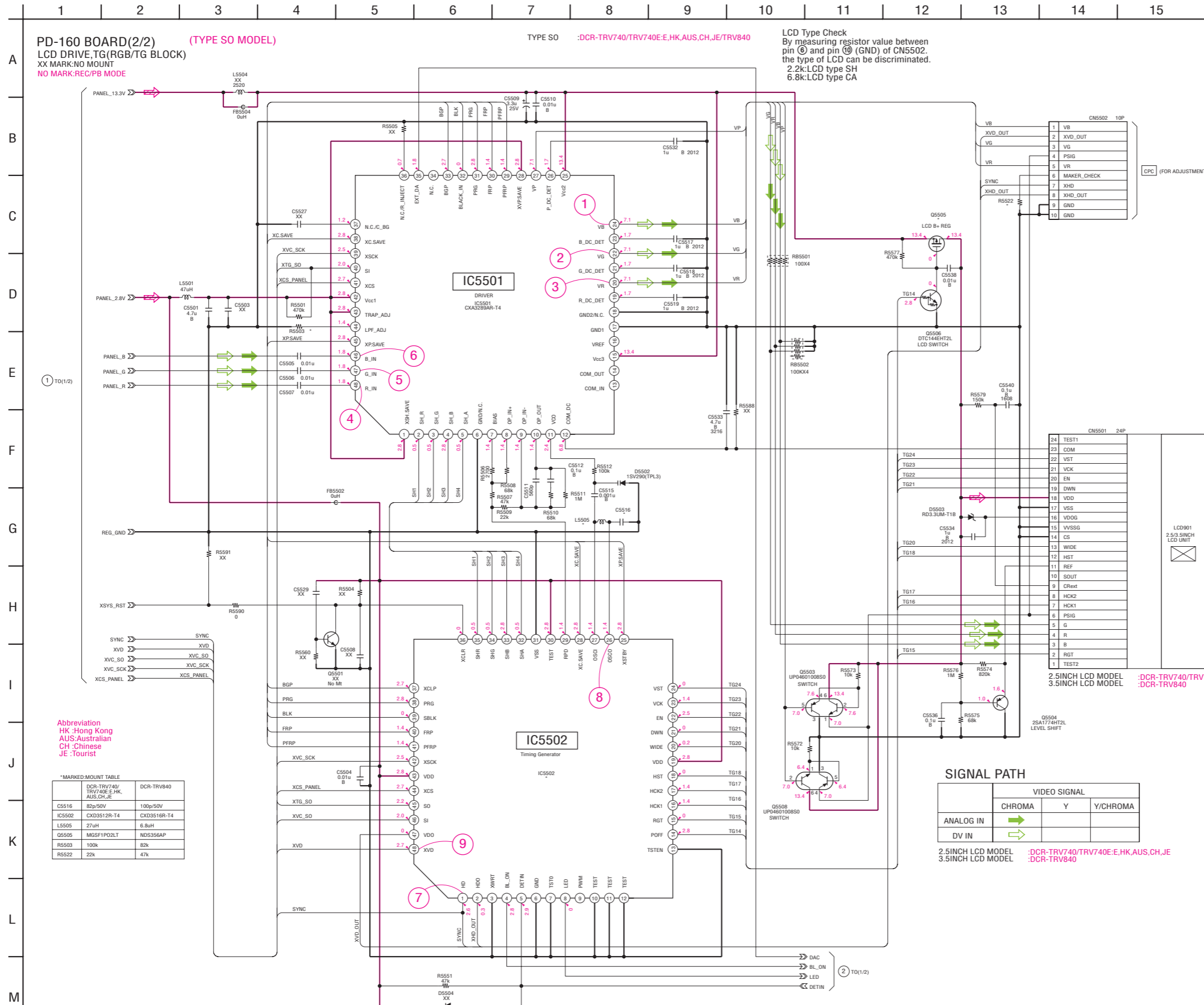

SIGNAL PATH

ANALOG IN	VIDEO SIGNAL		
	CHROMA	Y	Y/CHROMA
XVD	→		
XVD_OUT			→

2.5INCH LCD MODEL :DCR-TRV740/TRV740E:E,HK,AUS,CH,JE
 3.5INCH LCD MODEL :DCR-TRV840

CN5502 10P

1	VB
2	XVD_OUT
3	VG
4	PSIG
5	VR
6	MAKER_CHECK
7	XHD
8	XHD_OUT
9	GND
10	GND

CPC (FOR ADJUSTMENT)

CN5501 24P

24	TEST1
23	COM
22	VST
21	VCK
20	EN
19	DWN
18	VDD
17	VSS
16	VDOG
15	VVSSG
14	CS
13	WIDE
12	HST
11	REF
10	SOUT
9	CRext
8	HCK2
7	HCK1
6	PSIG
5	G
4	R
3	B
2	RGT
1	TEST2

LCD901 2.5/3.5INCH LCD UNIT

2.5INCH LCD MODEL :DCR-TRV740/TRV740E:E,HK,AUS,CH,JE
 3.5INCH LCD MODEL :DCR-TRV840

COVER

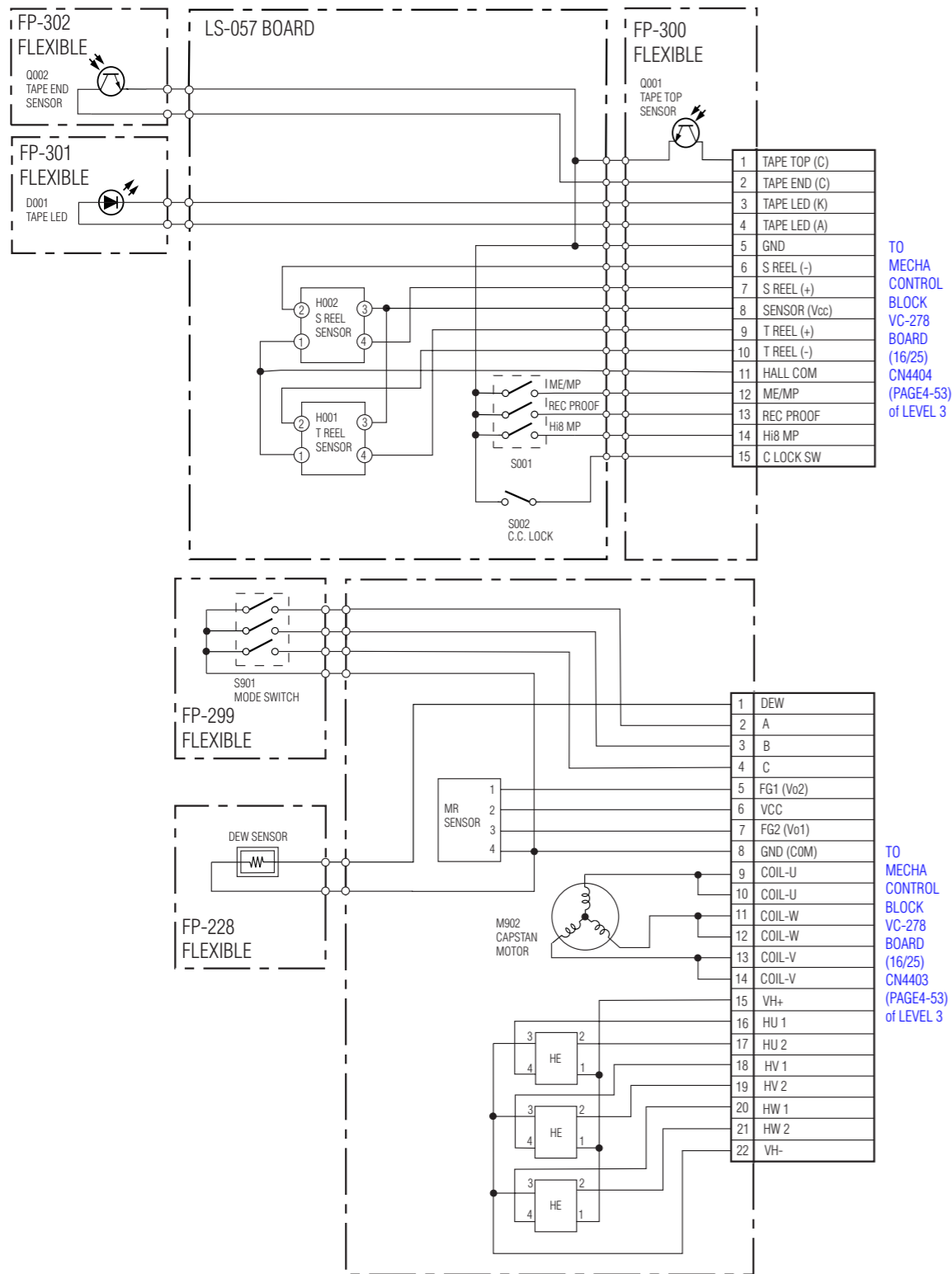

TO MECHA CONTROL BLOCK VC-278 BOARD (16/25) CN4404 (PAGE4-53) of LEVEL 3

TO MECHA CONTROL BLOCK VC-278 BOARD (16/25) CN4403 (PAGE4-53) of LEVEL 3

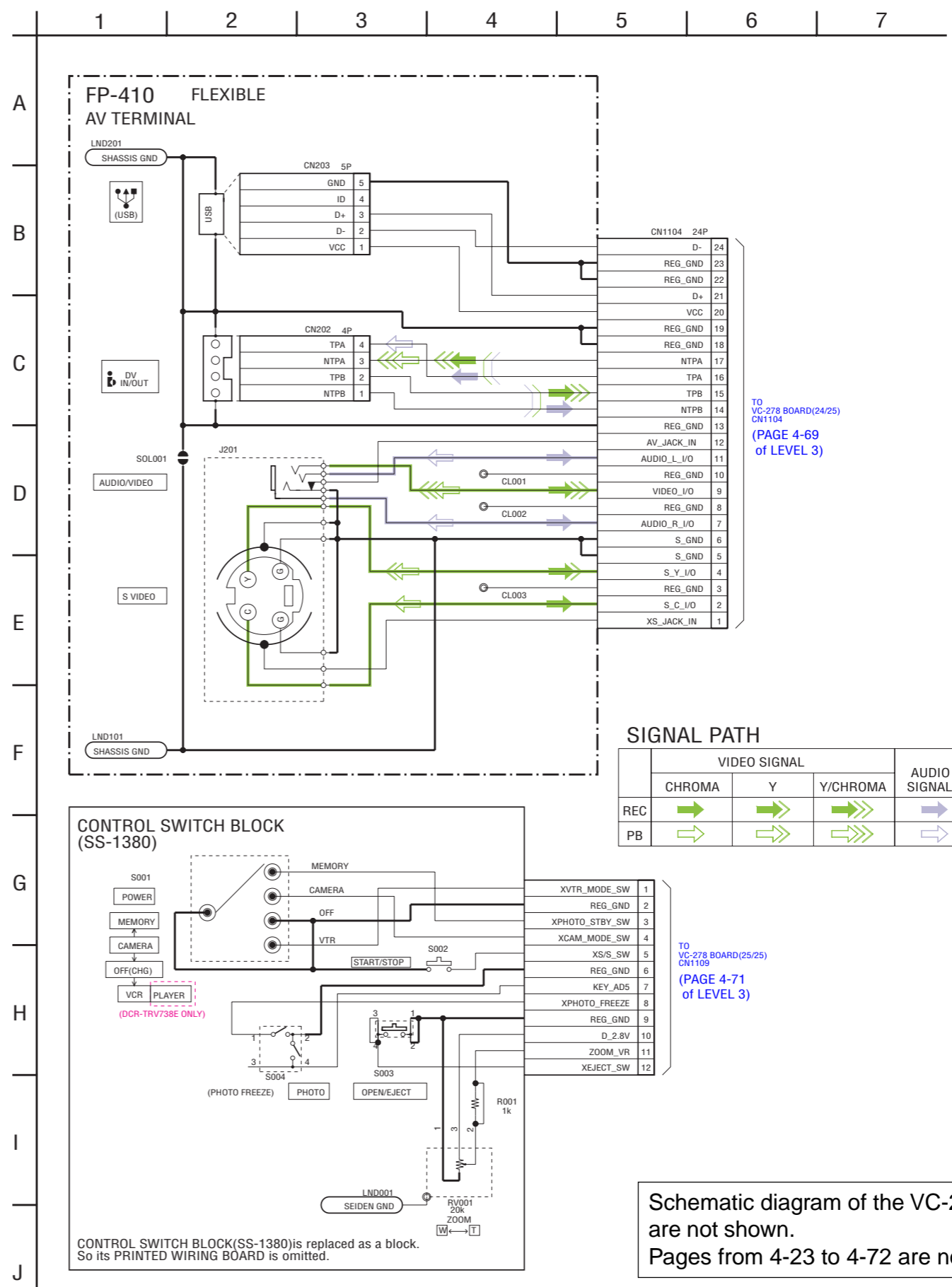

TO VC-278 BOARD(24/25) CN1104 (PAGE 4-69) of LEVEL 3)

SIGNAL PATH

	VIDEO SIGNAL			AUDIO SIGNAL
	CHROMA	Y	Y/CHROMA	
REC	→	→	→	→
PB	→	→	→	→

TO VC-278 BOARD(25/25) CN1109 (PAGE 4-71) of LEVEL 3)

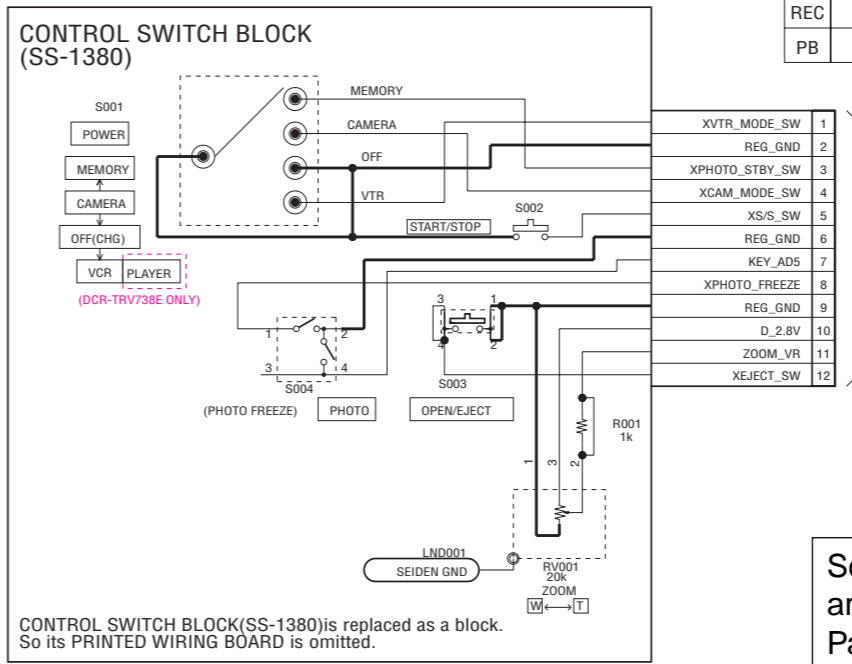

CONTROL SWITCH BLOCK(SS-1380)is replaced as a block. So its PRINTED WIRING BOARD is omitted.

Schematic diagram of the VC-278 board are not shown. Pages from 4-23 to 4-72 are not shown.



4-3. PRINTED WIRING BOARDS

Link

• CD-358 BOARD	• PD-156 BOARD (SIDE B)
• LB-076 BOARD	• PD-160 BOARD (SIDE A)
• SI-032 BOARD	• PD-160 BOARD (SIDE B)
• FP-411 FLEXIBLE BOARD	• FP-412 FLEXIBLE BOARD
• LS-057, FP-228, FP-299, FP-300, FP-302, FP-301 FLEXIBLE BOARDS	
• FP-410 FLEXIBLE BOARD	
• PD-156 BOARD (SIDE A)	

• COMMON NOTE FOR PRINTED WIRING BOARDS	• WAVEFORMS
• MOUNTED PARTS LOCATION	• CIRCUIT BOARDS LOCATION
	• FLEXIBLE BOARDS LOCATION



4-2. SCHEMATIC DIAGRAMS

4-3. PRINTED WIRING BOARDS

MOUNTED PARTS LOCATION

4-3. PRINTED WIRING BOARDS
CD-358 (CCD IMAGER) PRINTED WIRING BOARD
CD-358 BOARD
(SIDE A)

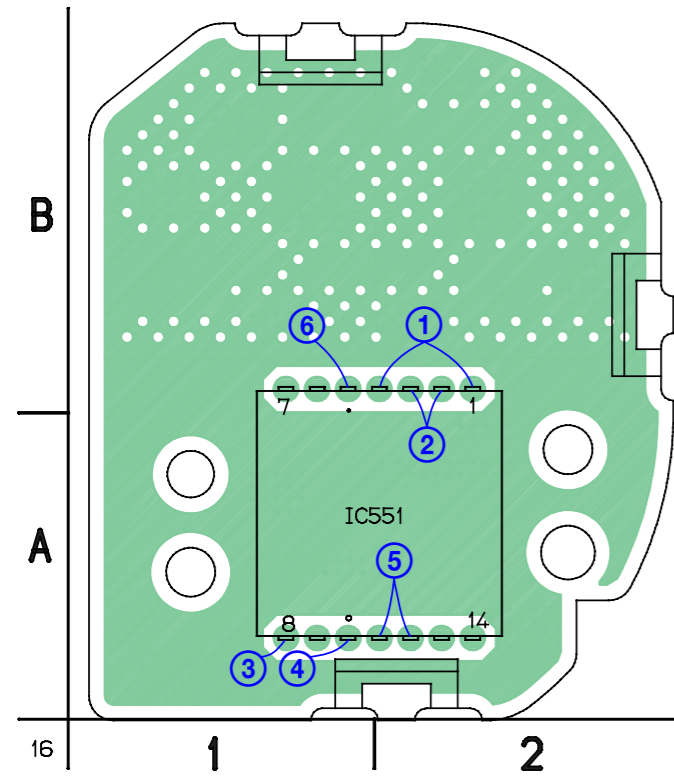

- For printed wiring boards**
- Refer to page 4-96 for parts location.
 - This board is eight-layer print board. However, the patterns of layers two and seven have not been included in the diagram.

There are a few cases that the part printed on this diagram isn't mounted in this model.

• : Uses unleaded solder.
CD-358 BOARD
(SIDE B)

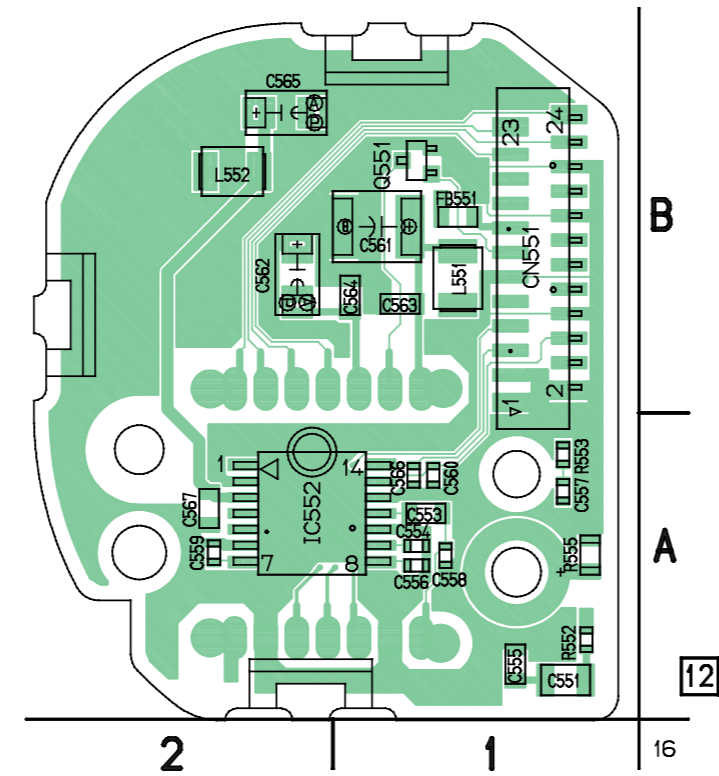

LB-076 (EVF, BACK LIGHT) PRINTED WIRING BOARD
LB-076 BOARD
(SIDE A)

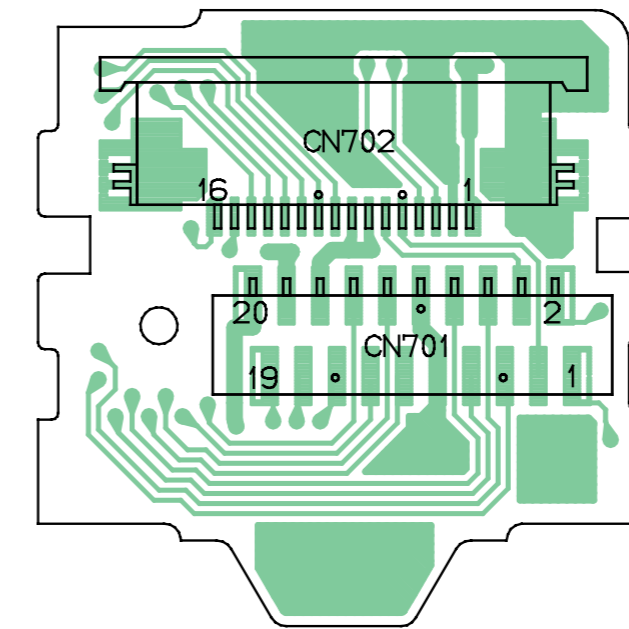

- For printed wiring boards**
- Refer to page 4-96 for parts location.
 - This board is eight-layer print board. However, the patterns of layers two and seven have not been included in the diagram.

There are a few cases that the part printed on this diagram isn't mounted in this model.

• : Uses unleaded solder.
LB-076 BOARD
(SIDE B)

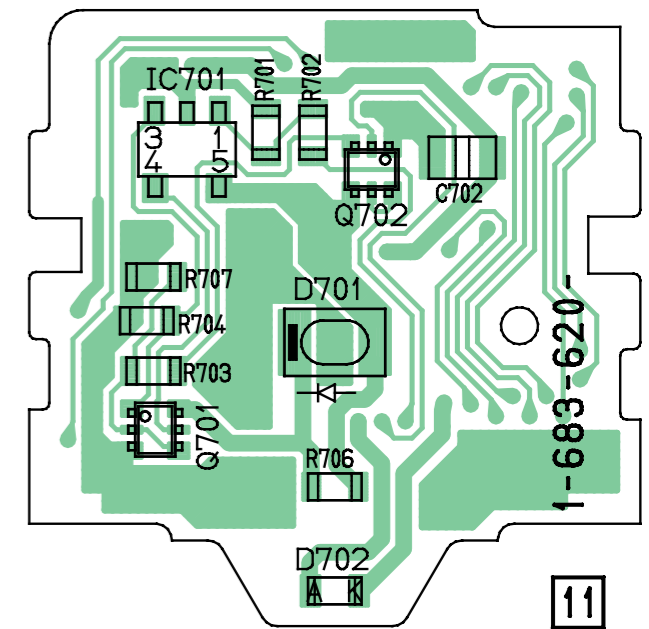



4-2. SCHEMATIC DIAGRAMS

4-3. PRINTED WIRING BOARDS

MOUNTED PARTS LOCATION

SI-032 (STEADY SHOT, LASER LINK) PRINTED WIRING BOARD

SI-032 BOARD (SIDE A)

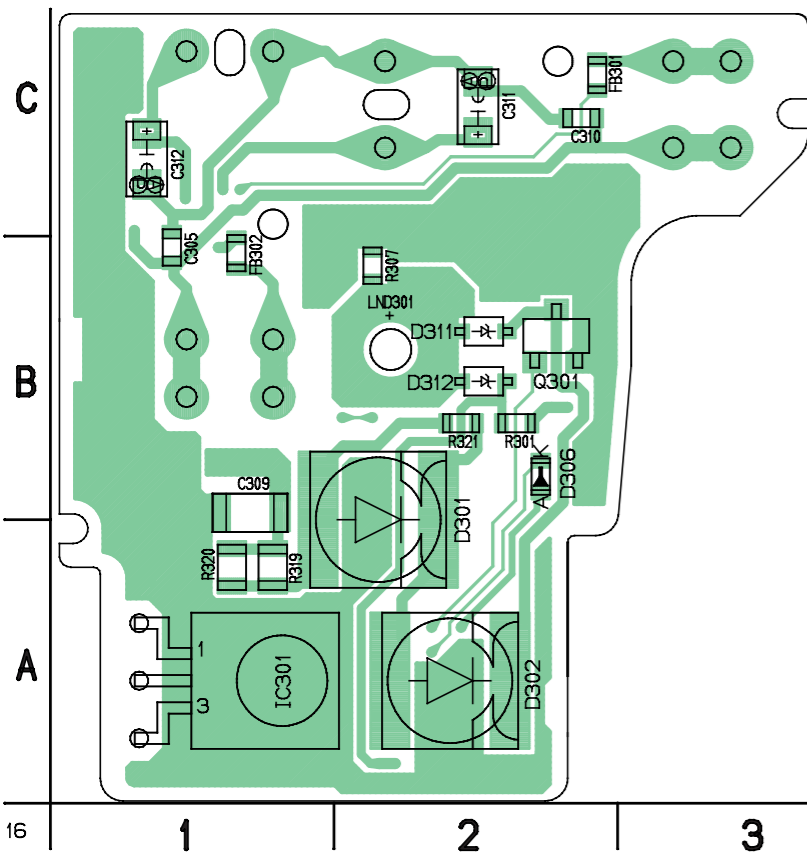

SI-032 BOARD (SIDE B)

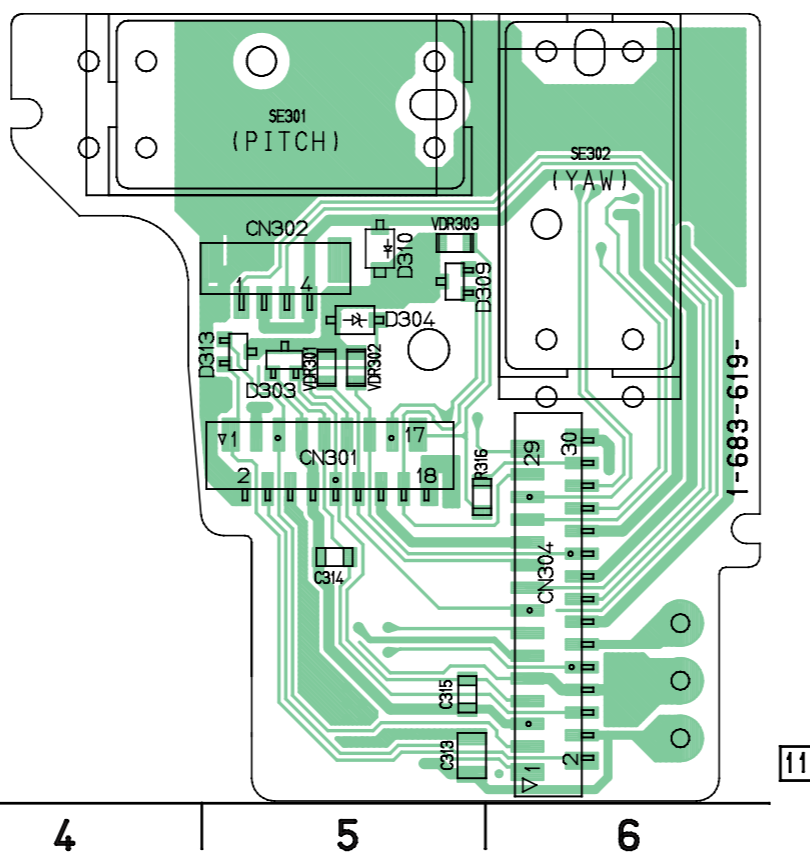

FP-411 FLEXIBLE BOARD

FP-411 FLEXIBLE

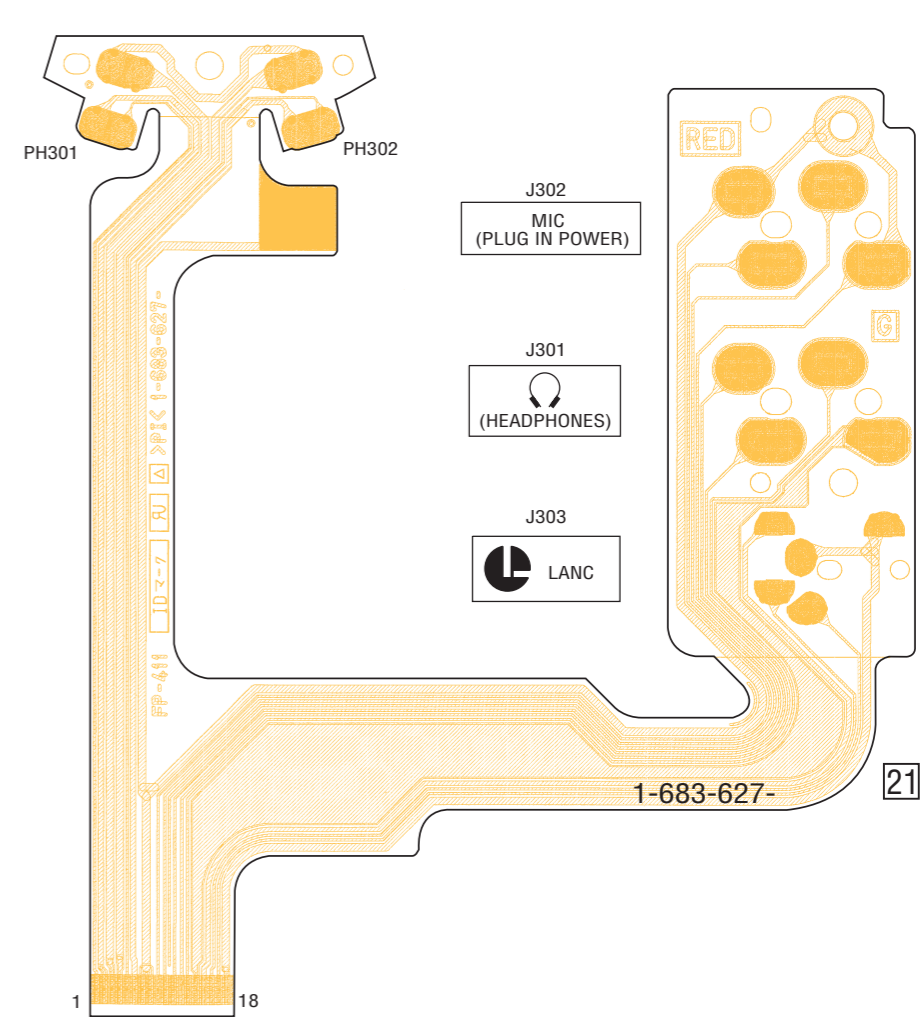

For printed wiring boards

- Refer to page 4-96 for parts location.
- This board is six-layer print board. However, the patterns of layers two and five have not been included in the diagram.

There are a few cases that the part printed on this diagram isn't mounted in this model.



4-2. SCHEMATIC DIAGRAMS

4-3. PRINTED WIRING BOARDS

LS-057 (S/T REEL SENSOR), FP-228 (DEW SENSOR), FP-299 (MODE SWITCH), FP-300 (TAPE TOP), FP-302 (TAPE END), FP-301 (TAPE LED) FLEXIBLE BOARDS
FP-300 FLEXIBLE (CONDUCTOR SIDE)

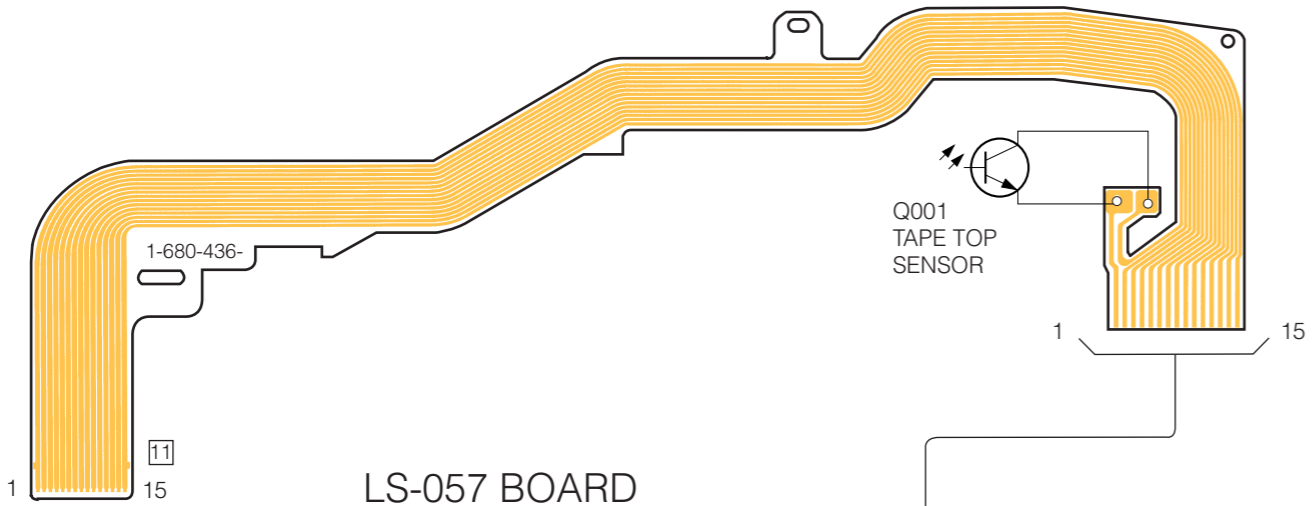

LS-057 BOARD (CONDUCTOR SIDE)

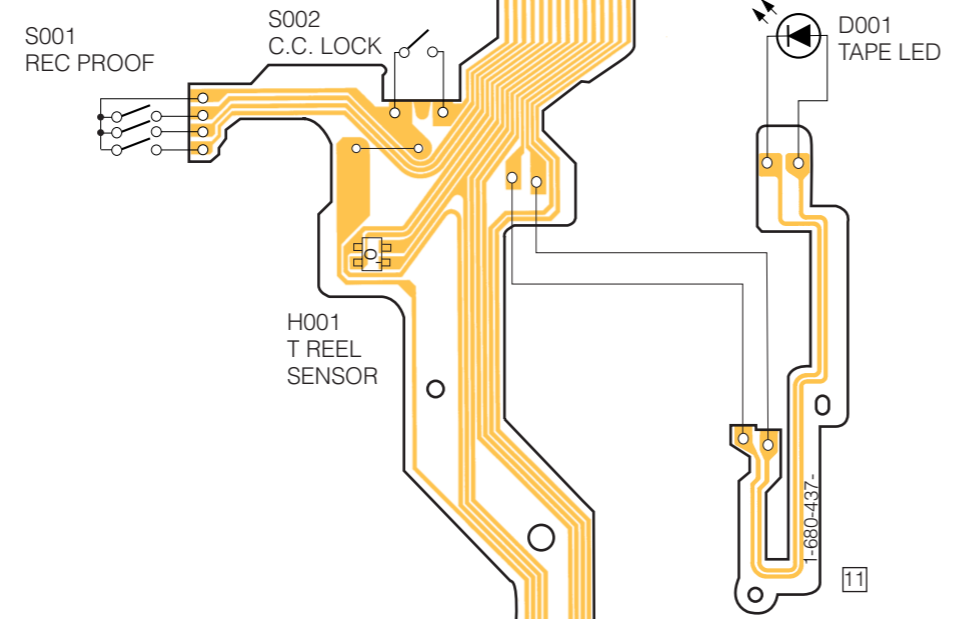

FP-301 FLEXIBLE (CONDUCTOR SIDE)

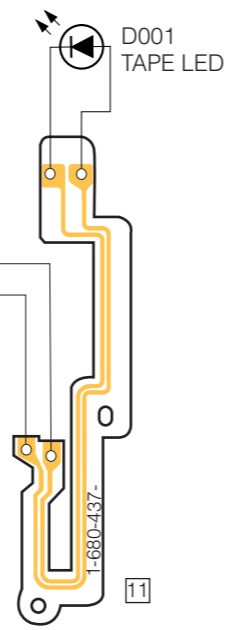

FP-302 FLEXIBLE (CONDUCTOR SIDE)

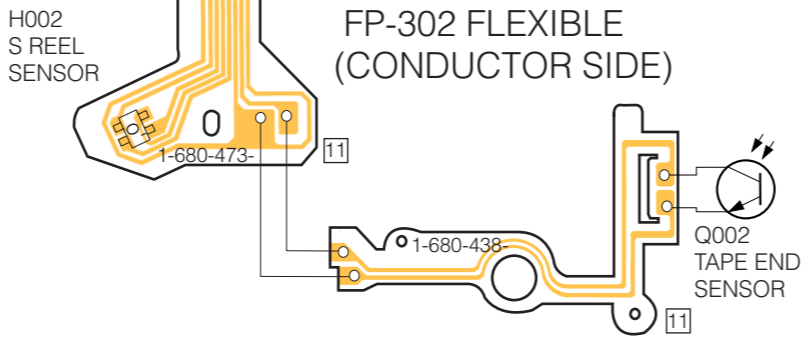

FP-410 FLEXIBLE BOARD

FP-410 FLEXIBLE

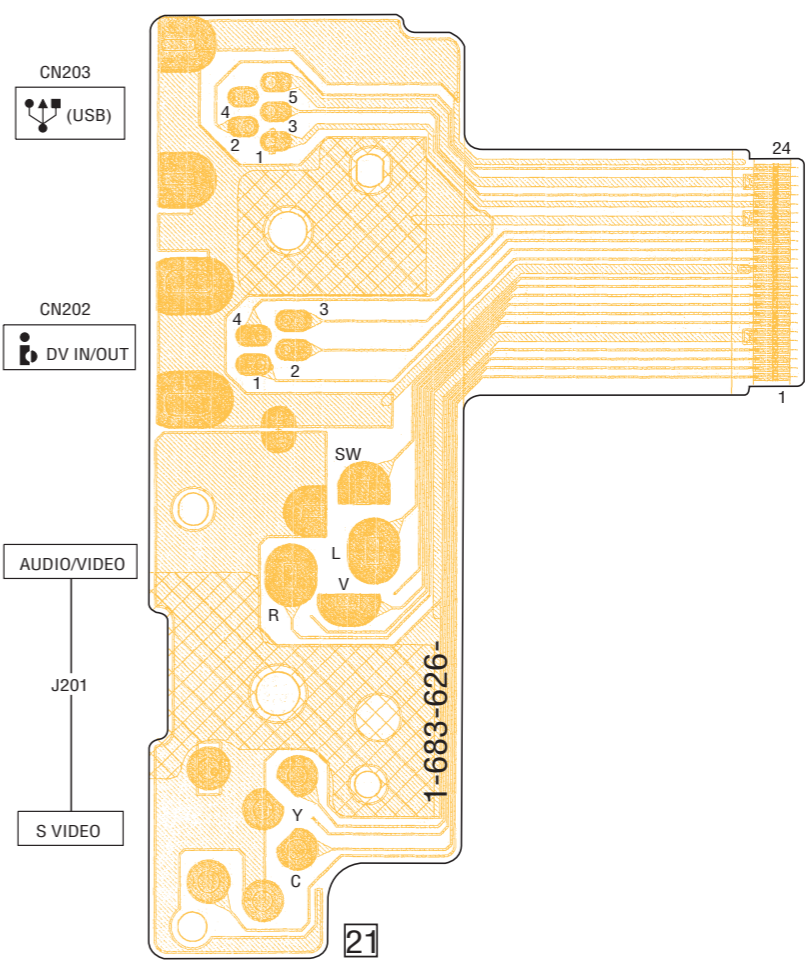



PD-156 (LCD DRIVER, BACKLIGHT, DRIVER, TIMING GENERATOR) PRINTED WIRING BOARD

• : Uses unleaded solder.

PD-156 BOARD (SIDE A) (TYPE CA and SH MODEL)

TYPE SH : TRV738E/TRV740E:AEP,EE,NE,RU
TYPE CA : TRV840

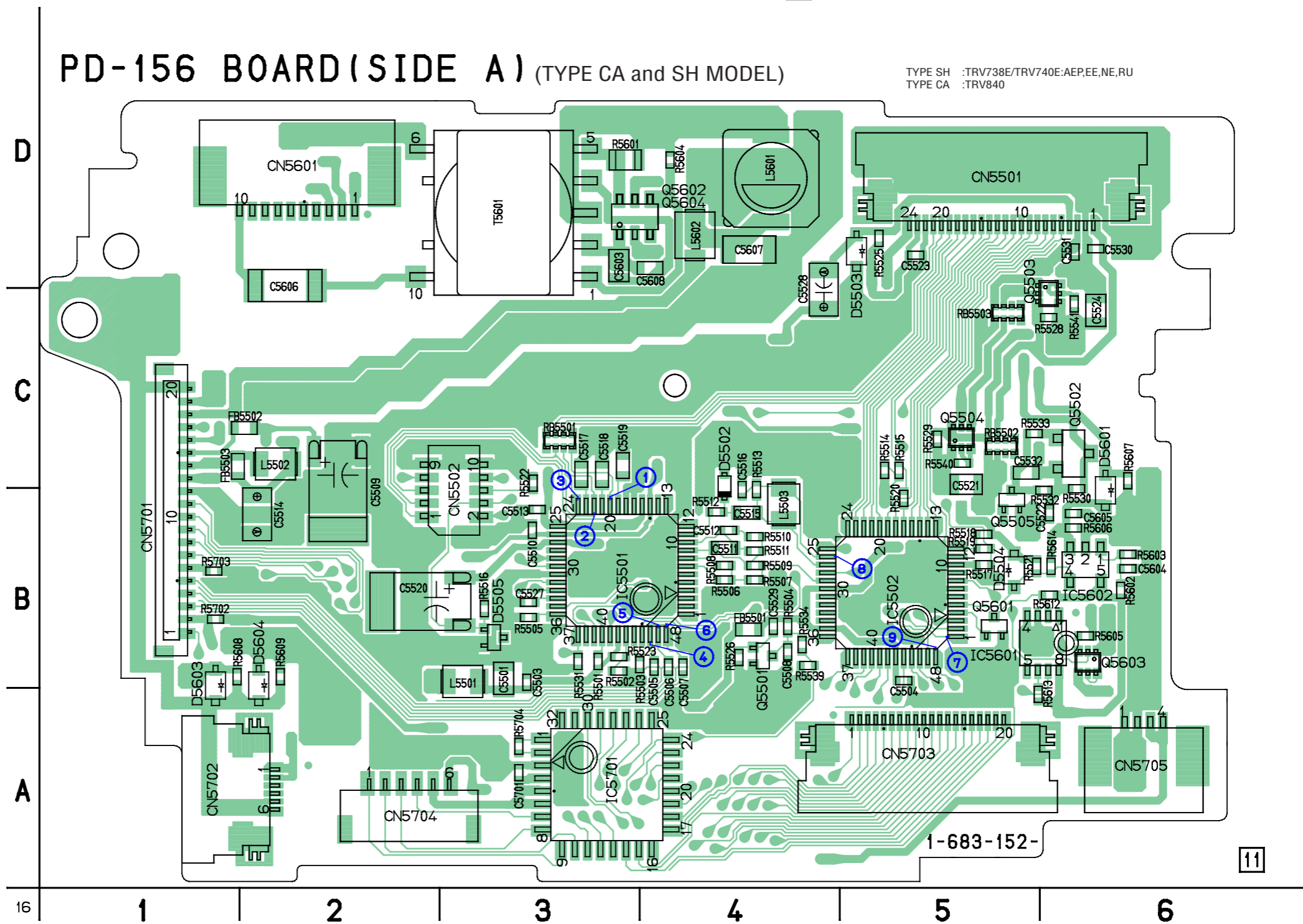

For printed wiring boards

- Refer to page 4-96 for parts location.
- This board is six-layer print board. However, the patterns of layers two and five have not been included in the diagram.

There are a few cases that the part printed on this diagram isn't mounted in this model.



•  : Uses unleaded solder.

PD-156 BOARD (SIDE B) (TYPE CA and SH MODEL)

TYPE SH :TRV738E/TRV740E:AEP,EE,NE,RU
TYPE CA :TRV840

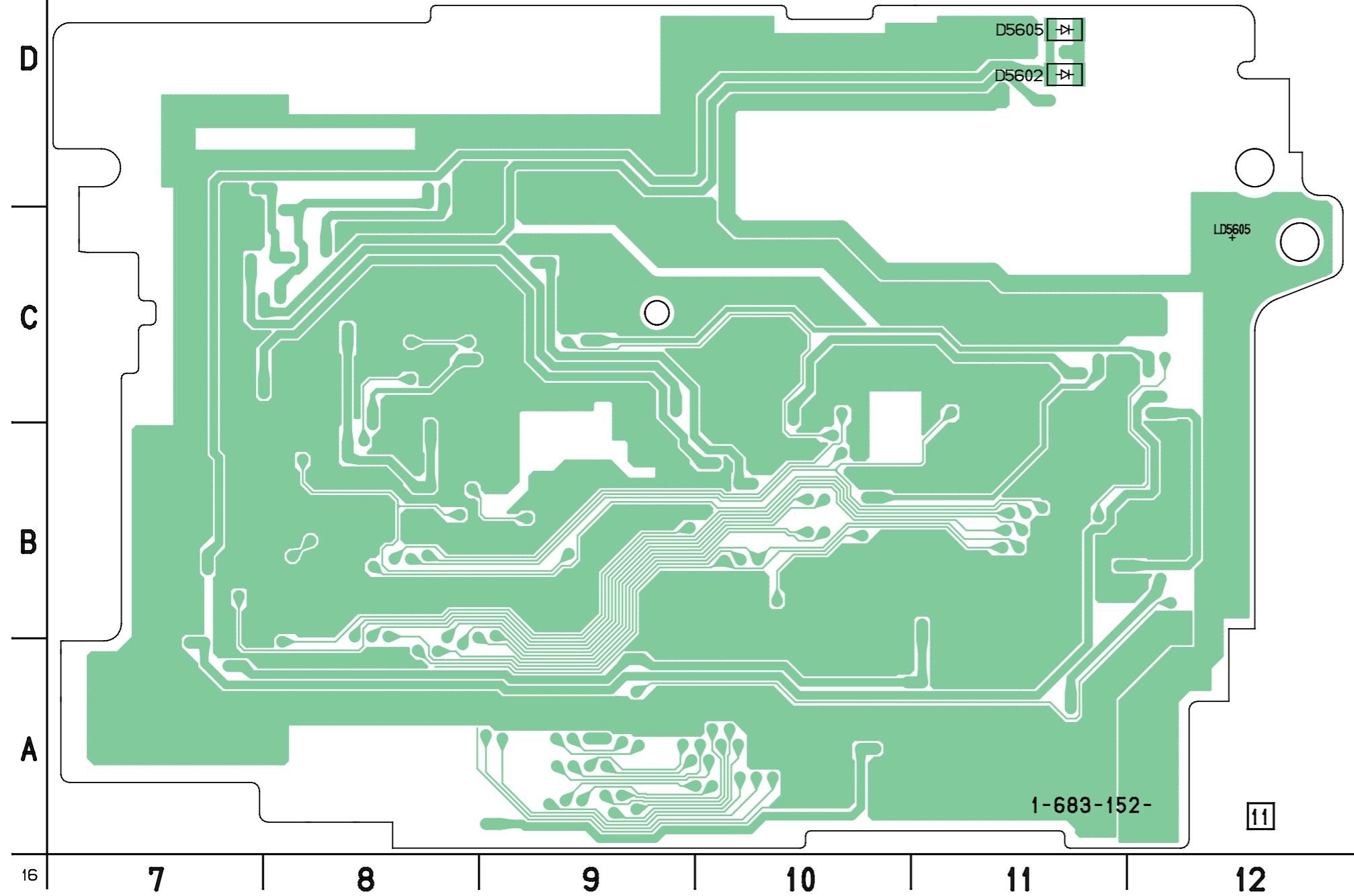



PD-160 (CHA, DISPLAY DRIVE, BACK LIGHT, LCD DRIVE, TG) PRINTED WIRING BOARD

• : Uses unleaded solder.

PD-160 BOARD (SIDE A) (TYPE SO MODEL)

TYPE SO :DCR-TRV740/TRV740E:E,HK,AUS,CH,JE/TRV840

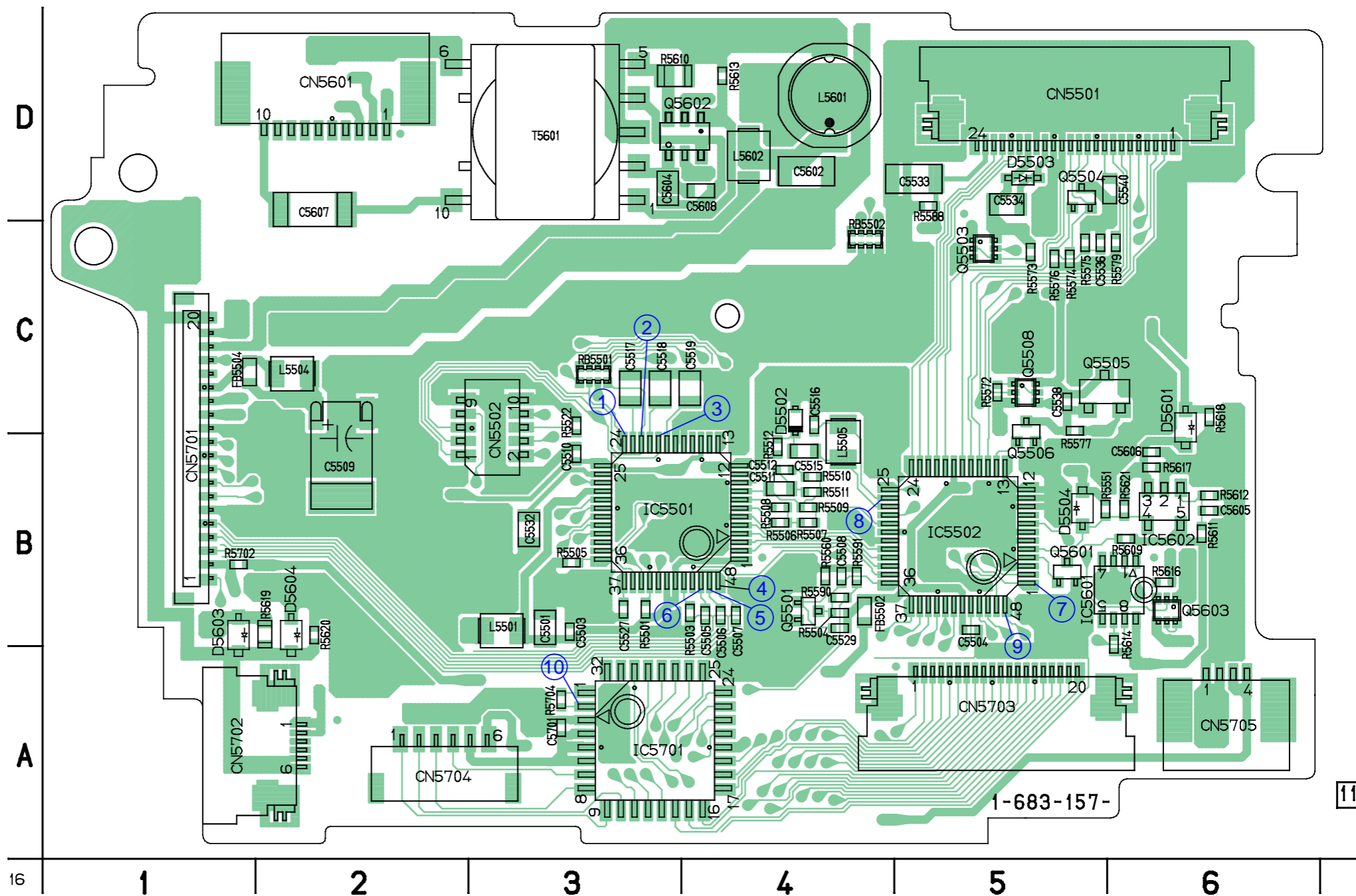

For printed wiring boards

- Refer to page 4-96 for parts location.
- This board is six-layer print board. However, the patterns of layers two and five have not been included in the diagram.

There are a few cases that the part printed on this diagram isn't mounted in this model.



• **LF** : Uses unleaded solder.

PD-160 BOARD (SIDE B) (TYPE SO MODEL)

TYPE SO :DCR-TRV740/TRV740E:E,HK,AUS,CH,JE/TRV840

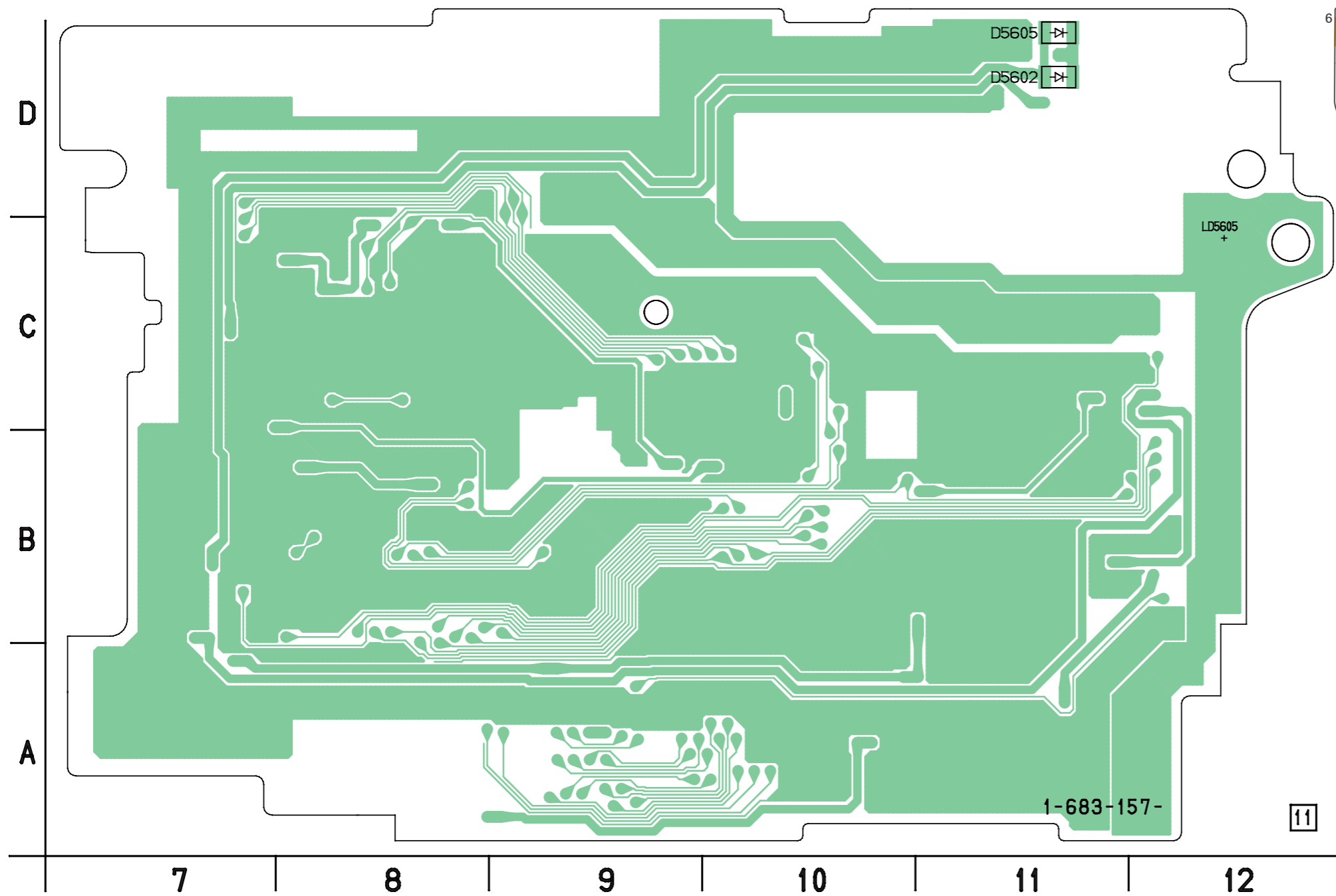

FP-412 FLEXIBLE BOARD

FP-412 FLEXIBLE

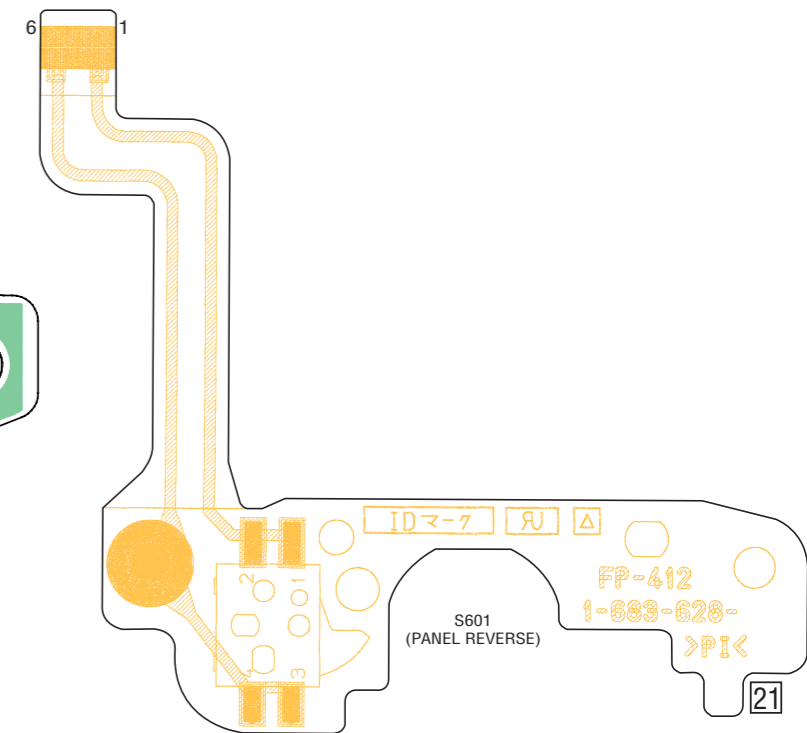

Printed wiring board of the VC-278 board are not shown.
Pages from 4-87 to 4-90 are not shown.



4-4. WAVEFORMS

CD-358 BOARD CAMERA REC

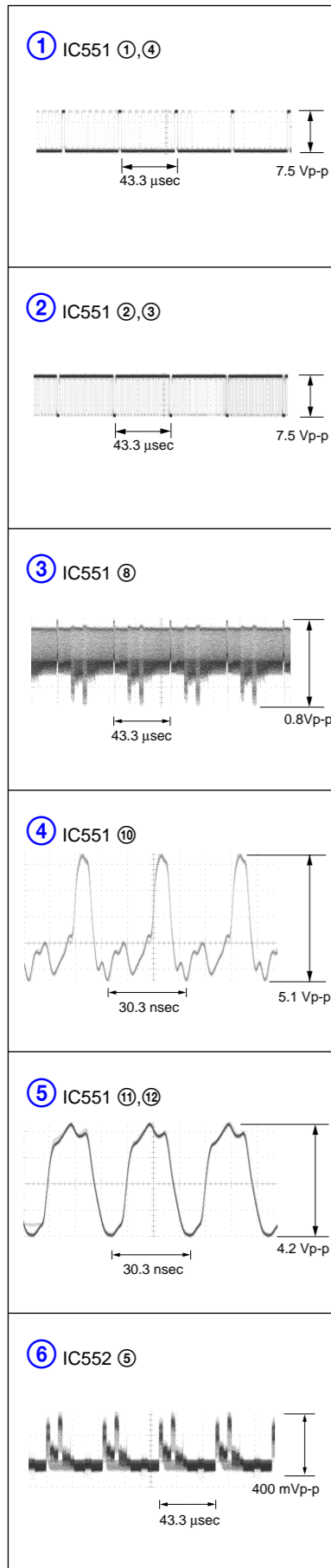

PD-156 BOARD

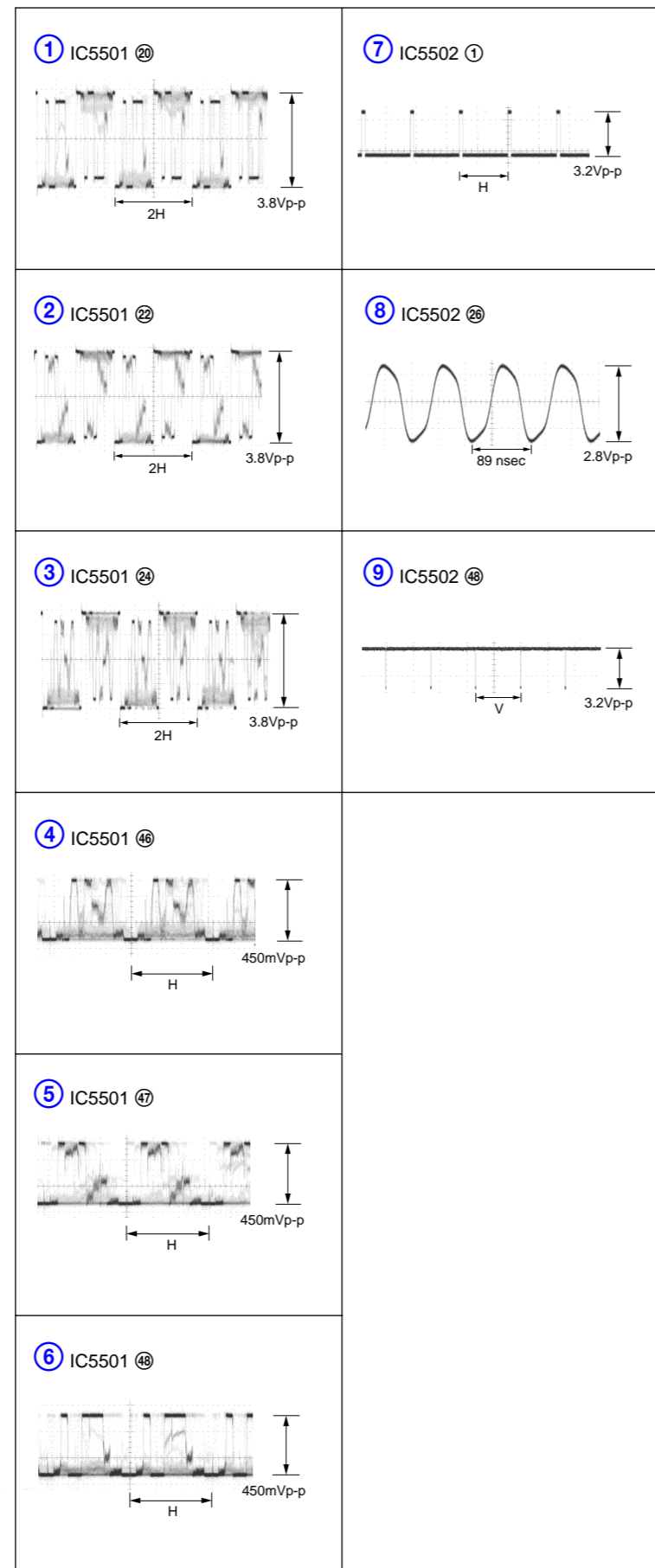

PD-160 BOARD

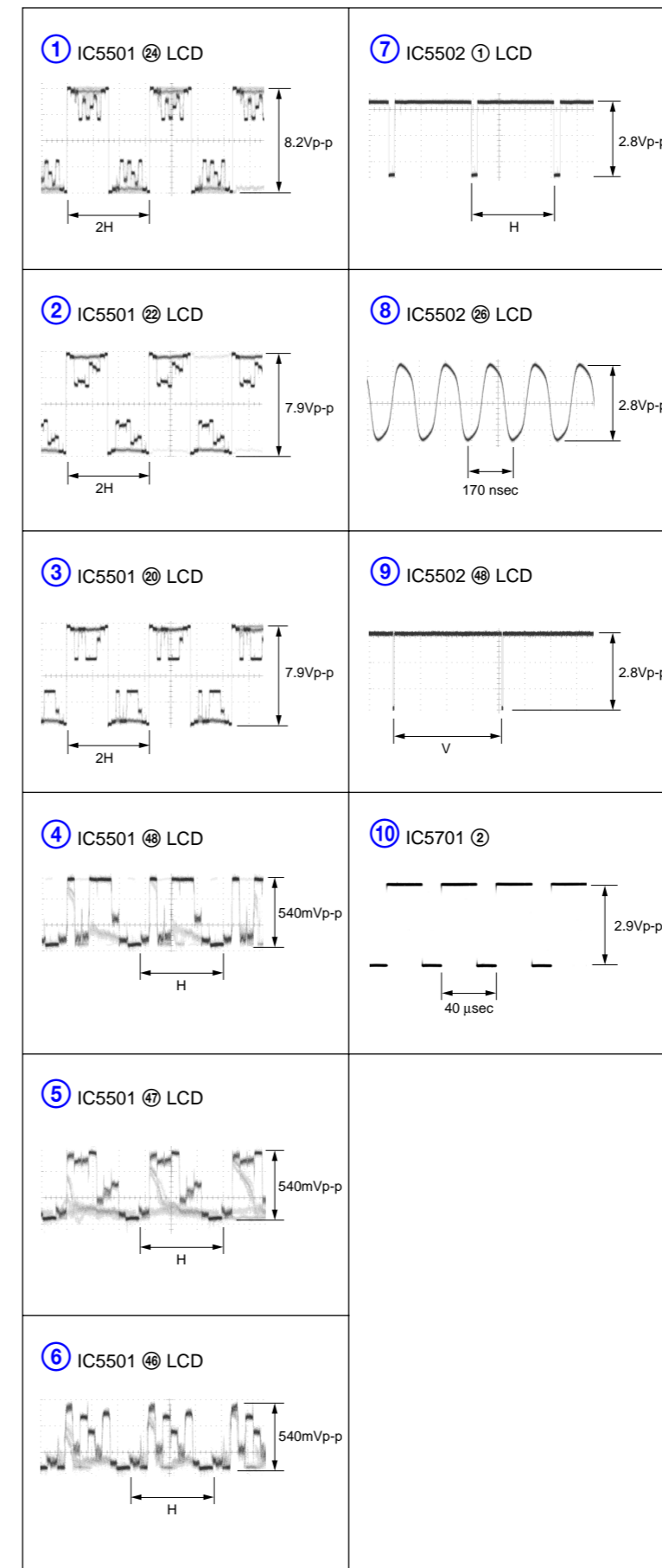

Waveforms of the VC-278 board are not shown.
Pages from 4-93 to 4-95 are not shown.



4-3. PRINTED WIRING BOARDS

4-5. MOUNTED PARTS LOCATION

no mark : side A

* mark : side B

CD-358 BOARD

* C551 A-1
 * C553 A-1
 * C554 A-1
 * C555 A-1
 * C556 A-1
 * C557 A-1
 * C558 A-1
 * C559 A-2
 * C560 A-1
 * C561 B-1
 * C562 B-2
 * C563 B-1
 * C564 B-1
 * C565 B-2
 * C566 A-1
 * C567 A-2

 * CN551 B-1

 * FB551 B-1

 IC551 A-1
 * IC552 A-2

 * L551 B-1
 * L552 B-2

 * Q551 B-1

 * R552 A-1
 * R553 A-1
 * R555 A-1

SI-032 BOARD

C305 B-1
 C309 B-1
 C310 C-2
 C311 C-2
 C312 C-1
 * C313 A-5
 * C314 A-5
 * C315 A-5

 * CN301 B-5
 * CN302 B-5
 * CN304 A-6

 D301 A-2
 D302 A-2
 * D303 B-5
 * D304 B-5
 D306 B-2
 * D309 B-5
 * D310 B-5
 D311 B-2
 D312 B-2
 * D313 B-5

 FB301 C-2
 FB302 B-1

 IC301 A-1

 Q301 B-2

 R301 B-2
 R307 B-2
 * R316 B-5
 R319 A-1
 R320 A-1
 R321 B-2

 * SE301 C-5
 * SE302 C-6

 * VDR301 B-5
 * VDR302 B-5
 * VDR303 B-5

PD-156 BOARD

C5501 B-3
 C5503 B-3
 C5504 B-5
 C5505 B-4
 C5506 B-4
 C5507 B-4
 C5508 B-4
 C5509 B-2
 C5510 B-3
 C5511 B-4
 C5512 B-4
 C5513 B-3
 C5514 B-2
 C5515 B-4
 C5516 B-4
 C5517 C-3
 C5518 C-3
 C5519 C-3
 C5520 B-2
 C5521 C-5
 C5522 B-6
 C5523 D-5
 C5524 C-6
 C5527 B-3
 C5528 D-4
 C5529 B-4
 C5530 D-6
 C5531 D-6
 C5532 C-5
 C5603 D-3
 C5604 B-6
 C5605 B-6
 C5606 D-2
 C5607 D-4
 C5608 D-4
 C5701 A-3

 CN5501 D-5
 CN5502 B-3
 CN5601 D-2
 CN5701 B-1
 CN5702 A-1
 CN5703 A-5
 CN5704 A-2
 CN5705 A-6

 D5502 B-4
 D5503 D-5
 D5504 B-5
 D5505 B-3
 D5601 C-6
 * D5602 D-11
 D5603 B-1
 D5604 B-2
 * D5605 D-11

 FB5501 B-4
 FB5502 C-2
 FB5503 C-1

 IC5501 B-3
 IC5502 B-5
 IC5601 B-5
 IC5602 B-6
 IC5701 A-3

 L5501 B-3
 L5502 C-2
 L5503 B-4

L5601 D-4
 L5602 D-4

 Q5501 B-4
 Q5502 C-6
 Q5503 C-6
 Q5504 C-5
 Q5505 B-5
 Q5601 B-5
 Q5602 D-4
 Q5603 B-6
 Q5604 D-4

 R5501 B-3
 R5502 B-3
 R5503 B-4
 R5504 B-4
 R5505 B-3
 R5506 B-4
 R5507 B-4
 R5508 B-4
 R5509 B-4
 R5510 B-4
 R5511 B-4
 R5512 B-4
 R5513 B-4
 R5514 C-5
 R5515 C-5
 R5516 B-3
 R5517 B-5
 R5518 B-5
 R5519 B-5
 R5520 B-5
 R5521 B-5
 R5522 C-3
 R5523 C-3
 R5524 C-3
 R5525 D-5
 R5526 B-4
 R5528 C-6
 R5529 C-5
 R5530 B-6
 R5531 B-3
 R5532 B-6
 R5533 C-5
 R5534 B-4
 R5539 B-4
 R5540 C-5
 R5541 C-6
 R5601 D-3
 R5602 B-6
 R5603 B-6
 R5604 D-4
 R5605 B-6
 R5606 B-6
 R5607 C-6
 R5608 B-1
 R5609 B-2
 R5612 B-6
 R5613 A-6
 R5614 B-6
 R5702 B-1
 R5703 B-1
 R5704 A-3

 RB5501 C-3
 RB5502 C-5
 RB5503 C-5

 T5601 D-3

PD-160 BOARD

C5501 B-3
 C5503 B-3
 C5504 B-5
 C5505 B-4
 C5506 B-4
 C5507 B-4
 C5508 B-4
 C5509 B-2
 C5510 B-3
 C5511 B-4
 C5512 B-4
 C5515 B-4
 C5516 C-4
 C5517 C-3
 C5518 C-3
 C5519 C-4
 C5527 B-3
 C5529 B-4
 C5532 B-3
 C5533 D-5
 C5534 D-5
 C5536 C-5
 C5538 C-5
 C5540 D-6
 C5602 D-4
 C5604 D-3
 C5605 B-6
 C5606 B-6
 C5607 D-2
 C5608 D-4
 C5701 A-3

 CN5501 D-5
 CN5502 C-3
 CN5601 D-2
 CN5701 B-1
 CN5702 A-1
 CN5703 A-5
 CN5704 A-2
 CN5705 A-6

 D5502 C-4
 D5503 D-5
 D5504 B-5
 D5601 C-6
 * D5602 D-11
 D5603 B-1
 D5604 B-2
 * D5605 D-11

 FB5502 B-4
 FB5504 C-1

 IC5501 B-3
 IC5502 B-5
 IC5601 B-6
 IC5602 B-6
 IC5701 A-3

 L5501 B-3
 L5504 C-2
 L5505 B-4
 L5601 D-4
 L5602 D-4

Q5501 B-4
 Q5503 C-5
 Q5504 D-5
 Q5505 C-5
 Q5506 B-5
 Q5508 C-5
 Q5601 B-5
 Q5602 D-3
 Q5603 B-6

 R5501 B-3
 R5503 B-4
 R5504 B-4
 R5505 B-3
 R5506 B-4
 R5507 B-4
 R5508 B-4
 R5509 B-4
 R5510 B-4
 R5511 B-4
 R5512 B-4
 R5522 C-3
 R5551 B-6
 R5560 B-4
 R5572 C-5
 R5573 C-5
 R5574 C-5
 R5575 C-5
 R5576 C-5
 R5577 B-5
 R5579 C-6
 R5588 D-5
 R5590 B-4
 R5591 B-4
 R5609 B-6
 R5610 D-3
 R5611 B-6
 R5612 B-6
 R5613 D-4
 R5614 B-6
 R5616 B-6
 R5617 B-6
 R5618 C-6
 R5619 B-2
 R5620 B-2
 R5621 B-6
 R5702 B-1
 R5704 A-3

 RB5501 C-3
 RB5502 C-4

 T5601 D-3

Mounted parts location of the VC-278 board is not shown.
 Pages from 4-97 to 4-98 are not shown.



**SECTION 5
ADJUSTMENTS**

Adjustment Section	Adjustment	Board replacement			EEPROM replacement		Supporting RadarW
		SI-032 board (COMPLETE)	PD-156/160 board (COMPLETE) *2 *3	VC-278 board (COMPLETE)	VC-278 board (EEPROM)	VC-278 board IC4903 (EEPROM) *4	
Initialization of 8, A, B, C, D, E, F, 1B, 1C, 1E, 1F page data	Initialization of A, D page data			●		●	
	Initialization of B, 1B page data			●		●	
	Initialization of 8, C, 1C page data			●	●		
	Initialization of E, F, 1E, 1F page data			●	●		
Camera	HALL adj.			●	●		●
	Flange back adj.			●	●		●
	Mechanical shutter adj.			●	●		●
	Black defective CCD adj.			●	●		●
	Color reproduction adj.			●	●		●
	AWB & LV standard data input			●	●		●
	Auto white balance adj.			●	●		●
	Steady shot check	●		●	●		●
EVF	VCO adj.			●	●		
	RGB AMP adj.			●	●		
	Contrast adj.			●	●		
LCD	VCO adj.		●	●	●		
	PSIG gray adj. *3		●	●	●		
	RGB AMP adj.		●	●	●		
	Black limit adj. *3		●	●	●		
	Contrast adj.		●	●	●		
	COM AMP adj.*2, Center level adj.*3		●	●	●		
	V-COM adj.		●	●	●		
White balance adj.		●	●	●			
System control	Serial No. input			●	●		
Servo & RF	REEL FG adj.			●	●		●
	Switching position adj.			●	●		●
	AGC center level adj.			●	●		●
	APC & AEQ adj.			●	●		●
	PLL fo & LPF fo adj.			●	●		●
	Hi8/Std8 switching position adj.			●	●		●
	CAP FG duty adj.			●	●		●
Video	54MHz/66MHz origin oscillation adj.			●	●		
	S VIDEO OUT Y level adj.			●	●		
	S VIDEO OUT chroma level adj.			●	●		
	Hi8/Std8 Y/C output level setting			●	●		●
	Hi8/Std8 AFC fo adj.			●	●		●
Audio	Hi8/Std8 AFM BPF fo adj.			●	●		
	Hi8/Std8 AFM 1.5MHz deviation adj.			●	●		
	Hi8/Std8 AFM 1.7MHz deviation adj.			●	●		
Mechanism	Tape path adj.						

*1: When replacing the drum assy. or mechanism deck, reset the data of page: 7, address: A7 to A9 to "00". (Refer to "Record of Use check" of "5-4. SERVICE MODE")

*2: LCD TYPE CA/SH (PD-156 board)
DCR-TRV738E
DCR-TRV740E: AEP, EE, NE, RU
DCR-TRV840

*3: LCD TYPE SO (PD-160 board)
DCR-TRV740
DCR-TRV740E: E, AUS, HK, CH, JE
DCR-TRV840

*4: When replacing the IC4903, set the loader writing inhibit mode. (Refer to "1-2-2. INITIALIZATION OF B, 1B PAGE DATA".)

• Abbreviation

- HK : Hong Kong model
- AUS : Australian model
- CH : Chinese model
- JE : Tourist model
- EE : East European model
- NE : North European model
- RU : Russian model

Table. 5-1-1 (2).

5-1. CAMERA SECTION ADJUSTMENT

1-1. PREPARATIONS BEFORE ADJUSTMENT (CAMERA SECTION)

1-1-1. List of Service Tools

- Oscilloscope
- Color monitor
- Vectorscope
- Regulated power supply
- Digital voltmeter

Ref. No.	Name	Parts Code	Usage
J-1	Filter for color temperature correction (C14)	J-6080-058-A	Auto white balance adjustment/check White balance adjustment/check
J-2	ND filter 1.0	J-6080-808-A	White balance check
	ND filter 0.4	J-6080-806-A	White balance check
	ND filter 0.1	J-6080-807-A	White balance check
J-3	Pattern box PTB-450	J-6082-200-A	
J-4	Color chart for pattern box	J-6020-250-A	
J-5	Adjustment remote commander (RM-95 upgraded) (Note1)	J-6082-053-B	
J-6	Siemens star chart	J-6080-875-A	For checking the flange back
J-7	Clear chart for pattern box	J-6080-621-A	
J-8	Multi CPC jig	J-6082-311-A	For adjusting the LCD block
J-9	CPC-13 jig	J-6082-443-A	For adjusting the video section For adjusting the color viewfinder
J-10	Minipattern box	J-6082-353-B	For adjusting the flange back
J-11	Camera base	J-6082-384-A	For adjusting the flange back

Note1: If the micro processor IC in the adjustment remote commander is not the new micro processor (UPD7503G-C56-12), the pages cannot be switched. In this case, replace with the new micro processor (8-759-148-35).

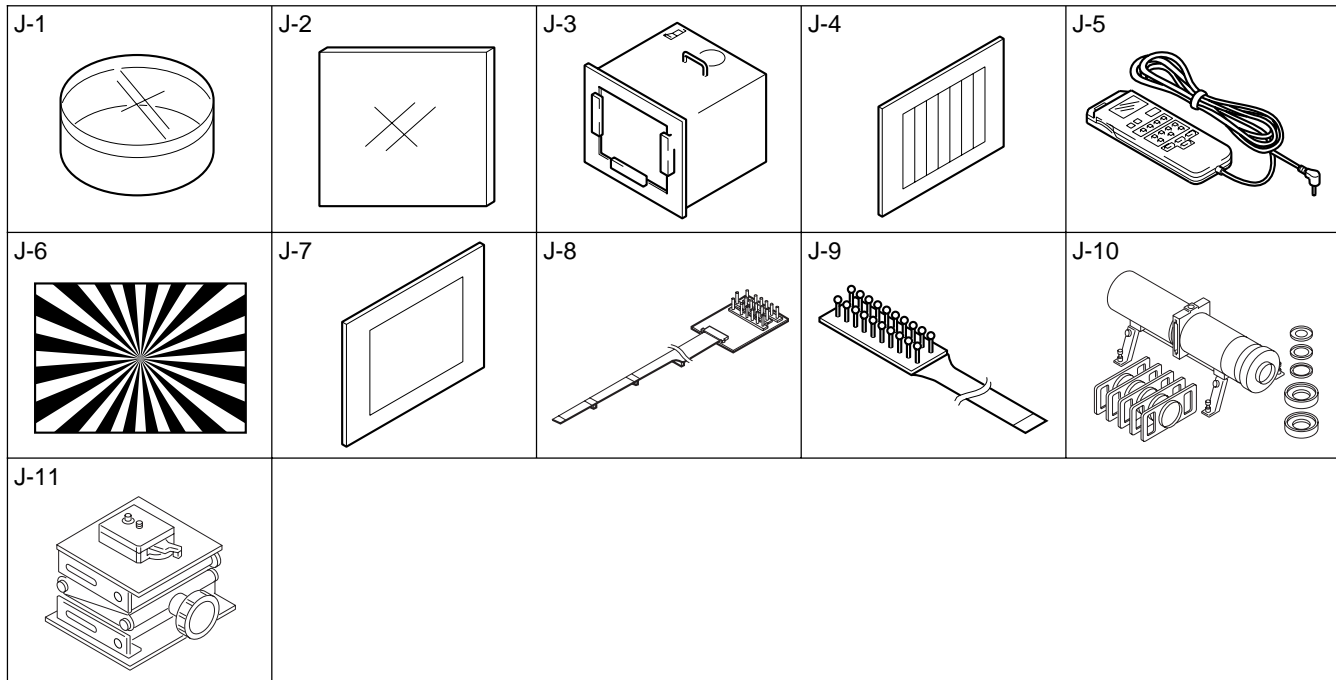

Fig. 5-1-1.

1-1-2. Preparations

Note1: For details of how remove the cabinet and boards, refer to “2. DISASSEMBLY”.

Note2: When performing only the adjustments, the lens block and boards need not be disassembled.

Note3: Before performing the adjustments, check the data of page: 0, address: 10 is “00”. If not, set data: 00 to this address.

- 1) Connect the equipment for adjustments according to Fig. 5-1-3.
- 2) The front panel block (SI-032 board (Microphone amp., remote commander receiver), FP-411 flexible (MIC jack, Head phone jack, LANC jack, MF photo sensor)) must be assembled for connecting the adjusting remote commander.

Note4: As removing the cabinet (R) assembly (removing CN1110 of the VC-278 board) means removing the lithium 3V power supply (BT001 on the CF-2500 block), data such as date, time, user-set menus will be lost. After completing adjustments, reset these data. But the self-diagnosis data and the data on history of use (total drum rotation time etc.) will be kept even if the lithium 3V power supply is removed. (Refer to “5-4.Service Mode” for the self-diagnosis data and the data on history of use.)

Note5: Setting the “Forced Camera Power ON” Mode

- 1) Select page: 0, address: 01, and set data: 01.
- 2) Select page: D, address: 10, set data: 01, and press the PAUSE button.

The above procedure will enable the camera power to be turned on with the SS-1380 block removed. After completing adjustments, be sure to exit the “Forced Camera Power ON Mode”.

Note6: Exiting the “Forced Camera Power ON” Mode

- 1) Select page: 0, address: 01, and set data: 01.
- 2) Select page: D, address: 10, set data: 00, and press the PAUSE button.
- 3) Select page: 0, address: 01, and set data: 00.

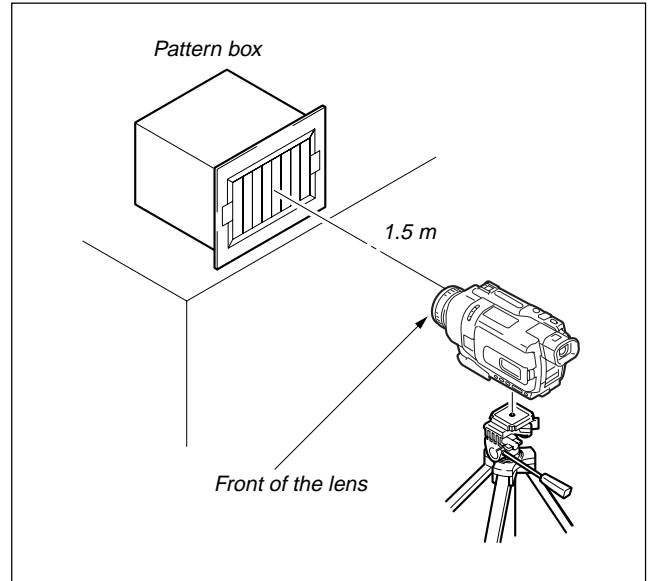

Fig. 5-1-2.

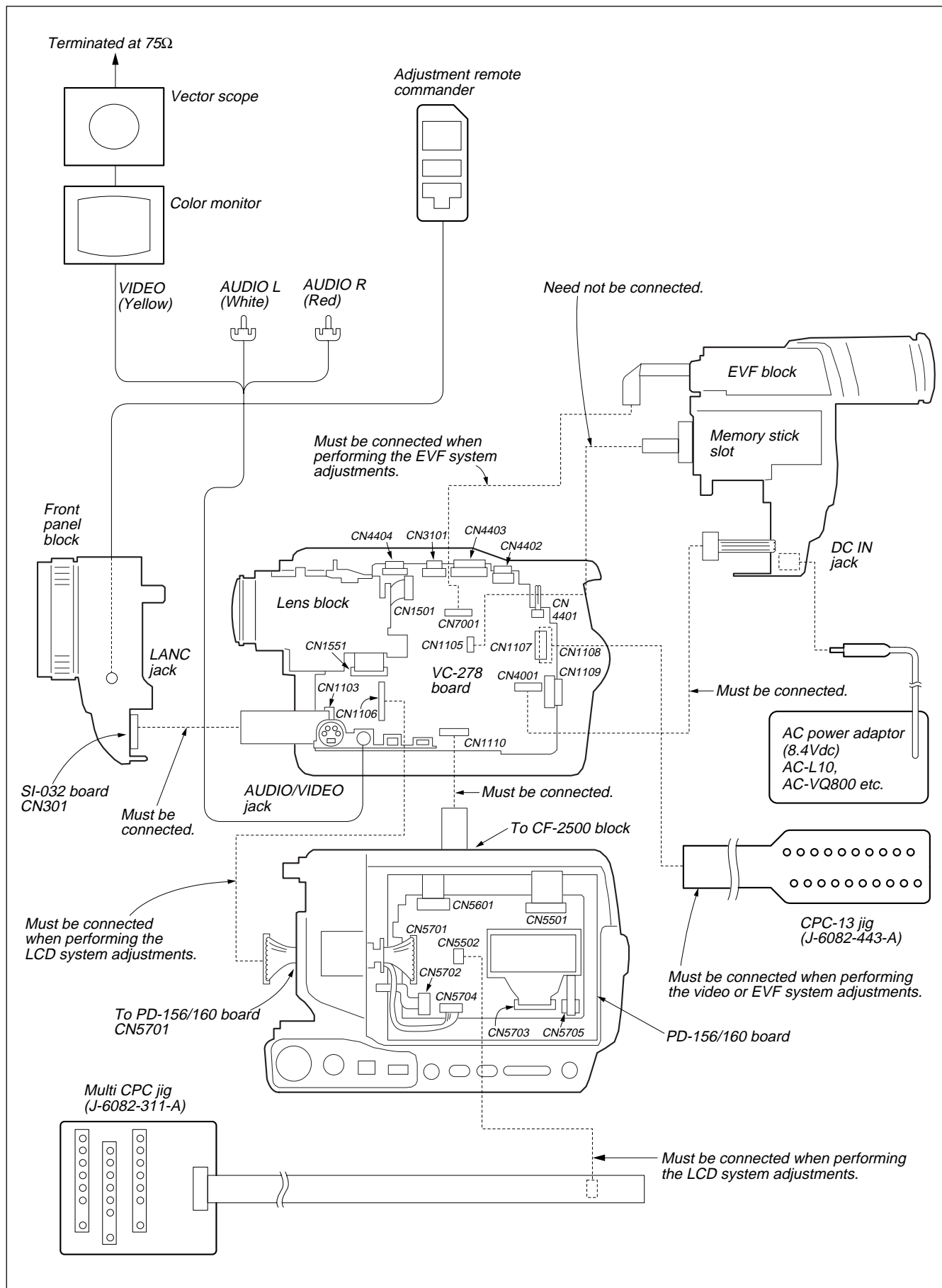

Fig. 5-1-3.

1-1-3. Precaution

1. Setting the Switch

Unless otherwise specified, set the switches as follows and perform adjustments without loading cassette.

- | | | | |
|---------------------------------------------|-----------|-----------------------------------------|--------|
| 1. POWER switch (SS-1380 block) | CAMERA | 9. FOCUS switch (CF-2500 block) | MANUAL |
| 2. NIGHT SHOT switch (Lens block) | OFF | 10. BACK LIGHT (CF-2500 block) | OFF |
| 3. COLOR SLOW SHUTTER (FK-2500 block) | OFF | 11. PROGRAM AE (Menu display) | OFF |
| 4. DEMO MODE (Menu display) | OFF | 12. PICTURE EFFECT (Menu display) | OFF |
| 5. DIGITAL ZOOM (Menu display) | OFF | 13. DIGITAL EFFECT (Menu display) | OFF |
| 6. STEADY SHOT (Menu display) | OFF | 14. AUTO SHUTTER (Menu display) | OFF |
| 7. DISPLAY (Menu display) | V-OUT/LCD | 15. 16 : 9 WIDE (MENU display) | OFF |
| 8. DISPLAY (CF-2500 block) | ON | | |

2. Order of Adjustments

Basically carry out adjustments in the order given.

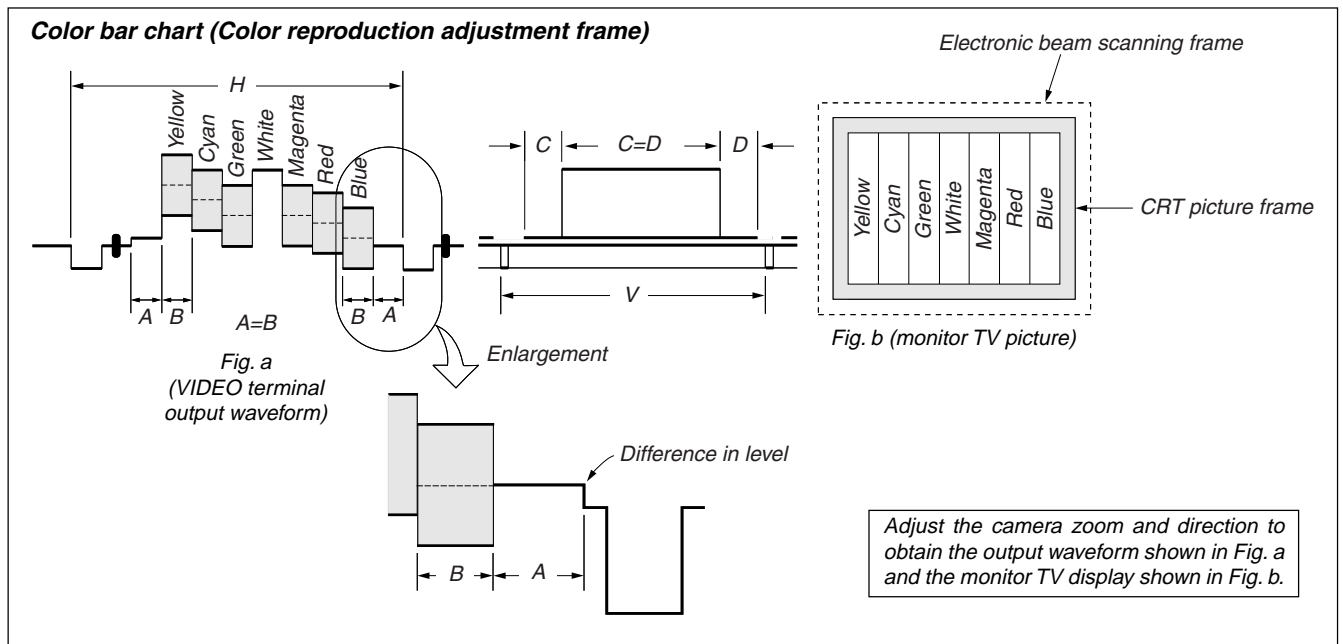

Fig.5-1-4.

3. Subjects

- 1) Color bar chart (Color reproduction adjustment frame)
When performing adjustments using the color bar chart, adjust the picture frame as shown in Fig. 5-1-4. (Color reproduction adjustment frame)
- 2) Clear chart (Color reproduction adjustment frame)
Remove the color bar chart from the pattern box and insert a clear chart in its place. (Do not perform zoom operations during this time.)
- 3) Flange back adjustment chart
Make the chart shown in Fig. 5-1-5 using A0 size (1189mm × 841mm) black and white vellum paper.

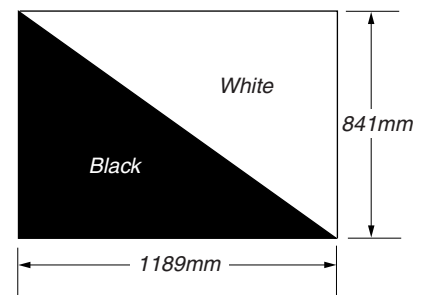

Fig. 5-1-5.

Note: Use matte vellum paper bigger than A0, and make sure the edges of the black and white paper joined together are not rough.

1-2. INITIALIZATION OF 8, A, B, C, D, E, F, 1B, 1C, 1E, 1F PAGE DATA

Note: When reading or writing the 1B, 1C, 1D, 1E or 1F page data, select page: 0, address: 10, and set data: 01, then select B, C, D, E or F page. The 1B, 1C, 1D, 1E or 1F page can be chosen by this data setting.

After reading or writing, reset the data of page: 0, address: 10 to "00".

[Initialization Procedure]

1. Initialization of A, D page data
2. Initialization of B, 1B page data
3. Initialization of 8, C, 1C page data
4. Initialization of E, F, 1E, 1F page data

[Connection of the power supply during the initialization of the data.]

- 1) Connect the regulated power supply and the digital voltmeter to the battery terminal as shown in Fig. 5-1-6.
- 2) Adjust the output voltage of the regulated power supply so that the digital voltmeter display is $6.0 \pm 0.1\text{Vdc}$.
- 3) Turn off the power supply.
- 4) Turn on the HOLD switch of the adjustment remote commander.
- 5) Turn on the power supply.
- 6) Perform the initialization of the data.

Note: This is normal though the following message is indicated on the LCD screen.

"FOR InfoLITHIUM BATTERY ONLY"

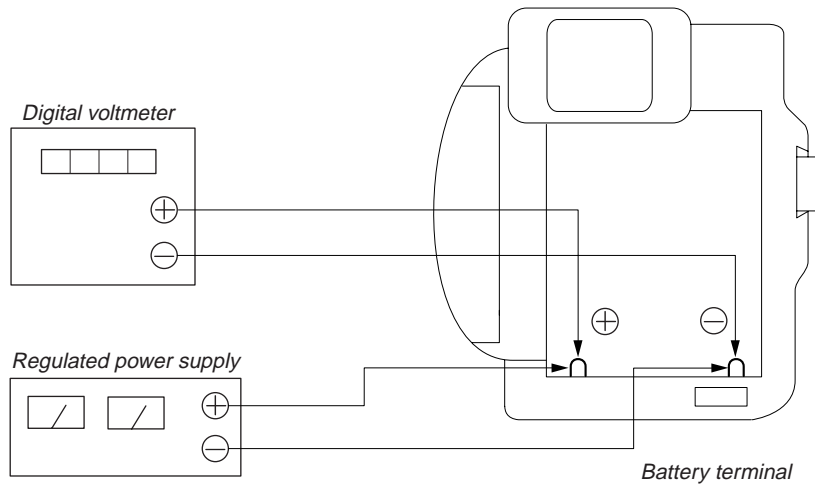

Fig. 5-1-6.

1-2-1. INITIALIZATION OF A, D PAGE DATA

Note: The data of page: 0, address: 10 must be "00".

1. Initializing the A, D Page Data

Note1: If "Initializing the A, D Page Data" is performed, all data of the A page and D page will be initialized. (It is impossible to initialize a single page.)

Note2: If the A, D page data has been initialized, the following adjustments need to be performed again.

1) Modification of A, D page data

Note3: The power supply voltage must be 6.0 ± 0.1 Vdc.

Note4: NTSC model: DCR-TRV740/TRV840

PAL model: DCR-TRV738E/TRV740E

Adjusting page	A
Adjusting Address	10 to FF
Adjusting page	D
Adjusting Address	10 to 67

Initializing Method:

Order	Page	Address	Data	Procedure
1	0	01	01	Set the data.
2	0	10	00	Set the data.
3	7	03		Set the following data. 01 (NTSC), 81 (PAL)
4	7	00	28	Set the data
5	7	01	28	Set the data, and press the PAUSE button.
6	7	02		Check that the data changes to "01"
7	2	00	29	Set the data.
8	2	01	29	Set the data, and press the PAUSE button.
9				Perform "Modification of A, D Page Data".

2. Modification of A, D Page Data

If the A, D page data has been initialized, change the data of the "Fixed data-2" address shown in the following tables by manual input.

Modifying Method:

- Before changing the data, select page: 0, address: 01, and set data: 01.
- New data for changing are not shown in the tables because they are different in destination. When changing the data, copy the data built in the same model.

Note: If copy the data built in the different model, the camcorder may not operate.

- When changing the data, press the PAUSE button of the adjustment remote commander each time when setting new data to write the data in the non-volatile memory.

Processing after Completing Modification of A, D Page data

Order	Page	Address	Data	Procedure
1	0	10	00	Set the data.
2	2	00	29	Set the data.
3	2	01	29	Set the data, and press PAUSE button.

Note: If the following symptoms occur after completing of the "Modification of A, D page data", check that the data of the "Fixed data-2" addresses of A and D page are same as those of the same model of the same destination.

- The self-diagnosis code "E:20:00" on the LCD screen is displayed.
- The power is shut off so that unit cannot operate.

3. A Page Table

Note1: The data of page: 0, address: 10 must be "00".

Note2: Fixed data-1: Initialized data. (Refer to "1. Initializing the A, D Page Data".)

Fixed data-2: Modified data. (Refer to "2. Modification of A, D Page Data".)

Address	Remark
00 to 0F	
10 to 17	Fixed data-1
18	Fixed data-2
19	Fixed data-1
1A	Fixed data-2
1B to 31	Fixed data-1
32	Fixed data-2
33 to 59	Fixed data-1
5A	Fixed data-2
5B to C1	Fixed data-1
C2	Fixed data-2
C3 to CF	Fixed data-1
D0	Fixed data-2
D1	
D2 to FF	Fixed data-1

Table 5-1-2.

4. D Page Table

Note1: The data of page: 0, address: 10 must be "00".

Note2: Fixed data-1: Initialized data. (Refer to "1. Initializing the A, D Page Data".)

Fixed data-2: Modified data. (Refer to "2. Modification of A, D Page Data".)

Address	Remark	
	Initial value	
00 to 0F		
10	00	Test mode
11 to 12		Fixed data-1
13		Fixed data-2
14 to 15		Fixed data-1
16		Fixed data-2
17 to 21		Fixed data-1
22		Fixed data-2 (Modified data. Copy the data built in the same model.)
23		
24		
25		
26		
27 to 29		Fixed data-1
2A		Fixed data-2
2B		
2C to 36		Fixed data-1
37		Fixed data-2
38		Fixed data-1
39		Fixed data-2
3A		
3B to 5E		Fixed data-1
5F		Fixed data-2
60 to 67		Fixed data-1

Table. 5-1-3.

1-2-2. INITIALIZATION OF B, 1B PAGE DATA

Note: When reading or writing the B page data, select page: 0, address: 10, and set data: 00.

When reading or writing the 1B page data, select page: 0, address: 10, and set data: 01, then select B page. The 1B page can be chosen by this data setting.

After reading or writing, reset the data of page: 0, address: 10 to "00".

1. Initializing the B, 1B Page Data

Note1: If "Initializing the B, 1B Page Data" is performed, all data of the B page and 1B page will be initialized. (It is impossible to initialize a single page.)

Note2: If the B, 1B page data has been initialized, the following adjustments need to be performed again.

1) Modification of B, 1B page data

Note3: The power supply voltage must be 6.0 ± 0.1 Vdc.

Adjusting page	B
Adjusting Address	00 to FF
Adjusting page	1B
Adjusting Address	00 to FF

Initializing Method:

Order	Page	Address	Data	Procedure
1	0	01	01	Set the data.
2	0	10	00	Set the data.
3	5	02	FF	Set the data.
4	5	01	F3	Set the data, and press PAUSE button.
5	5	00	01	Set the data, and press PAUSE button.
6	5	02		Check that the data changes to "00".
7	2	00	29	Set the data
8	2	01	29	Set the data, and press the PAUSE button.
9				Perform "Modification of B, 1B Page Data".

2. Modification of B, 1B Page Data

If the B, 1B page data has been initialized, change the data of the "Fixed data-2" address shown in the following tables by manual input.

Modifying Method:

- Before changing the data, select page: 0, address: 01, and set data: 01.
- When changing the B page data, select page: 0, address: 10, and set data: 00.
- When changing the 1B page data, select page: 0, address: 10, and set data: 01.
After completing the modification of 1B page data, reset the data of this address to "00".

- New data for changing are not shown in the tables because they are different in destination. When changing the data, copy the data built in the same model.

Note: If copy the data built in the different model, the camcorder may not operate.

- When changing the data, press the PAUSE button of the adjustment remote commander each time when setting new data to write the data in the non-volatile memory.

Processing after Completing Modification of B, 1B Page data:

Order	Page	Address	Data	Procedure
1	0	10	00	Set the data.
2	2	00	29	Set the data.
3	2	01	29	Set the data, and press PAUSE button.

3. Loader writing inhibit mode setting

When replacing the IC4903 (EEPROM), set the loader inhibit mode.

Setting Method:

Order	Page	Address	Data	Procedure
1	0	01	01	Set the data.
2	0	10	00	Set the data.
3	5	0E	00	Set the data, and press PAUSE button.
4	5	03	20	Set the data, and press PAUSE button.
5	5	01	FA	Set the data, and press PAUSE button.
6	5	00	01	Set the data, and press PAUSE button.
7	5	0E		Check that the data is "01".
8	2	00	29	Set the data
9	2	01	29	Set the data, and press the PAUSE button.

4. B Page Table

Note1: The data of page: 0, address: 10 must be "00".

Note2: Fixed data-1: Initialized data. (Refer to "1. Initializing the B, 1B Page Data".)
Fixed data-2: Modified data. (Refer to "2. Modification of B, 1B Page Data".)

Address	Remark
00 to FF	Fixed data-1

Table 5-1-4.

5. 1B Page Table

Note1: When reading or writing the 1B page data, select page: 0, address: 10, and set data: 01, then select B page. The 1B page can be chosen by this data setting.

After reading or writing, reset the data of page: 0, address: 10 to "00".

Note2: Fixed data-1: Initialized data. (Refer to "1. Initializing the B, 1B Page Data".)
Fixed data-2: Modified data. (Refer to "2. Modification of B, 1B Page Data".)

Address	Remark
00 to FF	Fixed data-1

Table 5-1-5.

1-2-3. INITIALIZATION OF 8, C, 1C PAGE DATA

Note: When reading or writing the 8, C page data, select page: 0, address: 10, and set data: 00.

When reading or writing the 1C page data, select page: 0, address: 10, and set data: 01, then select C page. The 1C page can be chosen by this data setting.

After reading or writing, reset the data of page: 0, address: 10 to "00".

1. Initializing the 8, C, 1C Page Data

Note1: If "Initializing the 8, C, 1C Page Data" is performed, all data of the 8 page, C page and 1C page will be initialized. (It is impossible to initialize a single page.)

Note2: If the 8, C, 1C page data has been initialized, following adjustments need to be performed again.

- 1) Modification of 8, C, 1C page data
- 2) Serial No. input
- 3) Viewfinder system adjustments
- 4) LCD system adjustments
- 5) Servo and RF system adjustments
- 6) Video system adjustments
- 7) Audio system adjustments

Note3: The power supply voltage must be $6.0 \pm 0.1Vdc$.

Adjusting page	8
Adjusting Address	00 to A3
Adjusting page	C
Adjusting Address	10 to FF
Adjusting page	1C
Adjusting Address	00 to FF

Initializing Method:

Order	Page	Address	Data	Procedure
1	0	01	01	Set the data.
2	0	10	00	Set the data.
3	3	81	10	Set the data.
4	3	80	0C	Set the data, and press PAUSE button.
5	3	80		Check that the data changes to "1C".
6	2	00	29	Set the data
7	2	01	29	Set the data, and press the PAUSE button.
8				Perform "Modification of 8, C, 1C Page Data".

2. Modification of 8, C, 1C Page Data

If the 8, C, 1C page data has been initialized, change the data of the "Fixed data-2" address shown in the following table by manual input.

Modifying Method:

- 1) Before changing the data, select page: 0, address: 01, and set data: 01.
- 2) When changing the 8, C page data, select page: 0, address: 10, and set data: 00.
- 3) When changing the 1C page data, select page: 0, address: 10, and set data: 01.

After completing the modification of 1C page data, reset the data of this address to "00".

- 4) New data for changing are not shown in the tables because they are different in destination. When changing the data, copy the data built in the same model.

Note: If copy the data built in the different model, the camcorder may not operate.

- 5) When changing the data, press the PAUSE button of the adjustment remote commander each time when setting new data to write the data in the non-volatile memory.
- 6) Check that the data of adjustment addresses is the initial value. If not, change the data to the initial value.

Processing after Completing Modification of 8, C, 1C Page data

Order	Page	Address	Data	Procedure
1	0	10	00	Set the data.
2	2	00	29	Set the data.
3	2	01	29	Set the data, and press PAUSE button.

3. 8 Page Table**Note1:** The data of page: 0, address: 10 must be "00".**Note2:** Fixed data-1: Initialized data. (Refer to "1. Initializing the 8, C, 1C Page Data".)

Fixed data-2: Modified data. (Refer to "2. Modification of 8, C, 1C Page Data".)

Address	Initial value	Remark
00 to 18		Fixed data-1
19		Fixed data-2
1A to 34		Fixed data-1
35		Fixed data-2
36 to 49		Fixed data-1
4A		Fixed data-2
4B to 51		Fixed data-1
52		Fixed data-2
53 to 79		Fixed data-1
7A		Fixed data-2
7B		(Modified data. Copy the data built in the same model.)
7C		
7D		
7E		
7F		
80		
81		
82		
83		
84		
85 to 89		Fixed data-1
8A		Fixed data-2
8B		Fixed data-1
8C	08	Serial No. input
8D	00	
8E	46	
8F	01	
90	02	
91	00	
92	00	
93	00	
84 to A3		Fixed data-1

Table. 5-1-6.

4. C Page Table**Note1:** The data of page: 0, address: 10 must be "00".**Note2:** Fixed data-1: Initialized data. (Refer to "1. Initializing the 8, C, 1C Page Data".)

Fixed data-2: Modified data. (Refer to "2. Modification of 8, C, 1C Page Data".)

Address	Initial value	Remark
00 to 0F		
10	EE	Switching position adj.
11	00	
12	00	
13	00	
14 to 15		Fixed data-1
16	E0	Hi8/std8 CAP FG duty adj.
17	E0	Reel FG adj.
18	20	AEQ adj.
19	20	
1A		Fixed data-1
1B	25	AEQ adj.
1C	25	
1D		Fixed data-1
1E	25	AGC center level adj.
1F	3E	PLL fo adj.
20	3E	
21	CA	APC adj.
22	99	LPF fo adj.
23 to 24		Fixed data-1
25	88	S VIDEO out Y level adj.
26	E3	S VIDEO out Cr level adj.
27	A1	S VIDEO out Cb level adj.
28		Fixed data-2
29	20	PLL fo adj.
2A to 2B		Fixed data-1
2C	03	APC adj.
2D		Fixed data-1
2E		Fixed data-2
2F	E0	Reel FG adj.
30 to 3C		Fixed data-1
3D		Fixed data-2
3E		Fixed data-1
3F		Fixed data-2
40	0A	Hi8/std8 switching position adj.
41	00	
42		Fixed data-1
43	50	Hi8/std8 AFC fo adj.
44	69	Hi8/Std8 Y/C output level set
45	64	
46 to 47		Fixed data-1
48		Fixed data-2
49		Fixed data-1
4A		Fixed data-2
4B		Fixed data-1
4C	A6	Hi8/std8 AFM 1.5MHz deviation adj.
4D	94	Hi8/std8 AFM 1.7MHz deviation adj.
4E	80	Hi8/std8 AFM BPF fo adj.
4F		Fixed data-2
50		

C page

Address	Initial value	Remark
51	61/69 *1	VCO adj. (EVF)
52	76/56 *1	
53		Fixed data-1
54	9D/9C *1	RGB AMP adj. (EVF)
55 to 57		Fixed data-1
58	2B/26 *1	Contrast adj. (EVF)
59		Fixed data-1
5A		Fixed data-2
5B to 5E		Fixed data-1
5F		Fixed data-2
60	8F/8A/86/ A7/8F *2	Fixed data
61	5C/51/5B/ 67/68 *2	VCO adj. (LCD)
62	70/54/62/ 53/59 *2	
63	21/85/24/ 8B/22 *2	V-COM adj. (LCD)
64	9D/20/B2/ 29/A1 *2	RGB AMP adj. (LCD)
65	08/00/07/ 00/08 *2	Fixed data *3 Black limit adj. (LCD) *4
66	3D/9D/3A/ 99/3F *2	COM AMP adj. *3 PSIG gray adj. (LCD) *4
67	7E/55/7E/ 84/81 *2	White balance adj. (LCD)
68	6C/3F/78/ 5F/6F *2	
69	20/37/2A/ 40/1E *2	Contrast adj. (LCD)
6A	37/00/2D/ 00/37 *2	Fixed data *3 Center level adj. (LCD)*4
6B	0C/50/0F/ 32/0C *2	Fixed data
6C	0C/10/0F/ 12/0C *2	
6D		
6E	5F/1F/DF/ 1F/5F *2	Fixed data
6F to 71		Fixed data-1
72		Fixed data-2
73 to 75		Fixed data-1
76		Fixed data-2
77 to 79		Fixed data-1
7A		Fixed data-2
7B to 81		Fixed data-1
81		Fixed data-2
82		
83 to 85		Fixed data-1
86		Fixed data-2
87 to 88		Fixed data-1
89		Fixed data-2
8A		
8B to A9		Fixed data-1
AA		Fixed data-2

Address	Initial value	Remark
AB		Fixed data-1
AC		Fixed data-2
AD to AE		Fixed data-1
AF		Fixed data-2
B0 to D4		Fixed data-1
D5		Fixed data-2
D6		
D7 to DC		Fixed data-1
DD		Fixed data-2
DE to E1		Fixed data-1
E2		Fixed data-2
E3		
E4 to F3		Fixed data-1
F4	00	Emergency memory address
F5	00	
F6	00	
F7	00	
F8	00	
F9	00	
FA	00	
FB	00	
FC	00	
FD	00	
FE	00	
FF	00	

*1: NTSC/PAL

*2: A/B/C/D/E

A: NTSC 2.5 LCD TYPE SO (DCR-TRV740)

B: NTSC 3.5 LCD TYPE CA (DCR-TRV840)

C: NTSC 3.5 LCD TYPE SO (DCR-TRV840)

D: PAL 2.5 LCD TYPE SH

(DCR-TRV738E/TRV740E (AEP/EE/NE/RU))

E: PAL 2.5 LCD TYPE SO

(DCR-TRV740E (E/AUS/HK/CN/JE))

*3: LCD TYPE CA or SH (PD-156 board)

*4: LCD TYPE SO (PD-160 board)

Table. 5-1-7.

5. 1C Page Table

Note1: When reading or writing the 1C page data, select page: 0, address: 10, and set data: 01, then select C page. The 1C page can be chosen by this data setting.

After reading or writing, reset the data of page: 0, address: 10 to "00".

Note2: Fixed data-1: Initialized data. (Refer to "1. Initializing the 8, C, 1C Page Data".)

Fixed data-2: Modified data. (Refer to "2. Modification of 8, C, 1C Page Data".)

Address	Remark
00 to 03	Fixed data-1
04	Fixed data-2
05 to 06	Fixed data-1
07	Fixed data-2
08	
09	Fixed data-1
0A	Fixed data-2
0B	(Modified data. Copy the data built in the same model.)
0C	
0D	
0E	
0F	Fixed data-1
10	Fixed data-2
11	
12 to 13	Fixed data-1
14	Fixed data-2
15	
16 to 17	Fixed data-1
18	Fixed data-2
19 to 1A	Fixed data-1
1B	Fixed data-2
1C	Fixed data-1
1D	Fixed data-2
1E	Fixed data-1
1F	Fixed data-2
20 to 22	Fixed data-1
23	Fixed data-2
24 to 26	Fixed data-1
27	Fixed data-2
28 to 39	Fixed data-1
3A	Fixed data-2
3B	Fixed data-1
3C	Fixed data-2
3D	(Modified data. Copy the data built in the same model.)
3E	
3F to 40	Fixed data-1
41	Fixed data-2
42 to 43	Fixed data-1
44	Fixed data-2
45	(Modified data. Copy the data built in the same model.)
46	
47	Fixed data-1
48	Fixed data-2
49	Fixed data-1
4A	Fixed data-2
4B to 4F	Fixed data-1
50	Fixed data-2
51 to 55	Fixed data-1

Address	Remark
56	Fixed data-2
57	
58 to 5A	Fixed data-1
5B	Fixed data-2
5C	Fixed data-1
5D	Fixed data-2
5E	Fixed data-1
5F	Fixed data-2
60	
61	Fixed data-1
62	Fixed data-2
63	(Modified data. Copy the data built in the same model.)
64	
65	
66	Fixed data-2
67	Fixed data-1
68	Fixed data-2
69	(Modified data. Copy the data built in the same model.)
6A	
6B to 6C	Fixed data-1
6D	Fixed data-2
6E	
6F	Fixed data-1
70	Fixed data-2
71	Fixed data-1
72	Fixed data-2
73	(Modified data. Copy the data built in the same model.)
74	
75	
76	
77	
78	Fixed data-1
79	Fixed data-2
7A	(Modified data. Copy the data built in the same model.)
7B	
7C	
7D	
7E	
7F	
80	
81	
82	Fixed data-2
83 to 85	Fixed data-1
86	Fixed data-2
87	(Modified data. Copy the data built in the same model.)
88	
89	
8A	
8B	
8C to 97	Fixed data-1
98	Fixed data-2
99 to 9E	Fixed data-1
9F	Fixed data-2
A0 to FF	Fixed data-1

Table. 5-1-8.

1-2-4. INITIALIZATION OF E, F, 1E, 1F PAGE DATA

Note: When reading or writing the E, F page data, select page: 0, address: 10, and set data: 00.

When reading or writing the 1E or 1F page data, select page: 0, address: 10, and set data: 01, then select E or F page. The 1E or 1F page can be chosen by this data setting.

After reading or writing, reset the data of page: 0, address: 10 to "00".

1. Initializing the E, F, 1E, 1F Page Data

Note1: If "Initializing the E, F, 1E, 1F Page Data" is performed, all data of the E page, F page, 1E page and 1F page will be initialized. (It is impossible to initialize a single page.)

Note2: If the E, F, 1E, 1F page data has been initialized, following adjustments need to be performed again.

- 1) Modification of E, F, 1E, 1F page data
- 2) 54MHz/66MHz origin osc. Adj.
- 3) Camera system adjustments

Note3: The power supply voltage must be 6.0 ± 0.1 Vdc.

Note4: NTSC model: DCR-TRV840
PAL model: DCR-TRV738E/TRV740E

Adjusting page	E
Adjusting Address	00 to FF
Adjusting page	F
Adjusting Address	10 to FF
Adjusting page	1E
Adjusting Address	00 to 2F
Adjusting page	1F
Adjusting Address	00 to FF

Initializing Method:

Order	Page	Address	Data	Procedure
1	0	01	01	Set the data.
2	0	10	00	Set the data.
3	6	01		Set the following data, and press PAUSE button. 2D (NTSC), 2F (PAL)
4	6	03	01	Set the data, and press PAUSE button.
5	6	02		Check that the data changes to "01".
6	2	00	29	Set the data
7	2	01	29	Set the data, and press the PAUSE button.
8				Perform "Modification of E, F, 1E, 1F Page Data".

2. Modification of E, F, 1E, 1F Page Data

If the E, F, 1E, 1F page data has been initialized, change the data of the "Fixed data-2" address shown in the following table by manual input.

Modifying Method:

- 1) Before changing the data, select page: 0, address: 01, and set data: 01.
- 2) When changing the E, F page data, select page: 0, address: 10, and set data: 00.
- 3) When changing the 1E, 1F page data, select page: 0, address: 10, and set data: 01.
After completing the modification of 1E, 1F page data, reset the data of this address to "00".
- 4) New data for changing are not shown in the tables because they are different in destination. When changing the data, copy the data built in the same model.
Note: If copy the data built in the different model, the camcorder may not operate.
- 5) When changing the data, press the PAUSE button of the adjustment remote commander each time when setting new data to write the data in the non-volatile memory.
- 6) Check that the data of adjustment addresses is the initial value. If not, change the data to the initial value.

Processing after Completing Modification of E, F, 1E, 1F Page data

Order	Page	Address	Data	Procedure
1	0	10	00	Set the data.
2	2	00	29	Set the data.
3	2	01	29	Set the data, and press PAUSE button.

3. E Page Table

Note1: The data of page: 0, address: 10 must be "00".

Note2: Fixed data-1: Initialized data. (Refer to "1. Initializing the E, F, 1E, 1F Page Data".)
Fixed data-2: Modified data. (Refer to "2. Modification of E, F, 1E, 1F Page Data".)

Address	Remark
00 to 04	Fixed data-1
05	Fixed data-2
06 to 07	Fixed data-1
08	Fixed data-2
09	(Modified data. Copy the data built in the same model.)
0A	
0B	
0C to 0C	Fixed data-1
0D	Fixed data-2
0E	
0F to 1A	Fixed data-1
1B	Fixed data-2
1C to 1F	Fixed data-1
20	Fixed data-2
21	(Modified data. Copy the data built in the same model.)
22	
23	
24	Fixed data-1
25	Fixed data-2
26	(Modified data. Copy the data built in the same model.)
27	
28 to 3B	Fixed data-1
3C	Fixed data-2
3D	(Modified data. Copy the data built in the same model.)
3E	
3F	
40 to 41	Fixed data-1
42	Fixed data-2
43 to 46	Fixed data-1
47	Fixed data-2
48 to 53	Fixed data-1
54	Fixed data-2
55	
56 to 5A	Fixed data-1
5B	Fixed data-2
5C	(Modified data. Copy the data built in the same model.)
5D	
5E	
5F	
60	Fixed data-1
61	Fixed data-2
62	(Modified data. Copy the data built in the same model.)
63	
64 to 65	Fixed data-1
66	Fixed data-2
67	(Modified data. Copy the data built in the same model.)
68	
69	
6A to 6E	Fixed data-1

Address	Remark
6F	Fixed data-2
70	(Modified data. Copy the data built in the same model.)
71	
72 to 9B	Fixed data-1
9C	Fixed data-2
9D	Fixed data-1
9E	Fixed data-2
9F to CD	Fixed data-1
CE	Fixed data-2
CF to DF	Fixed data-1
E0	Fixed data-2
E1	
E2	Fixed data-1
E3	Fixed data-2
E4	(Modified data. Copy the data built in the same model.)
E5	
E6	
E7	
E8	
E9	
EA	
EB to EE	
EF	Fixed data-2
F0 to F6	Fixed data-1
F7	Fixed data-2
F8 to FF	Fixed data-1

Table. 5-1-9.

4. F Page Table

Note1: The data of page: 0, address: 10 must be "00".

Note2: Fixed data-1: Initialized data. (Refer to "1. Initializing the E, F, 1E, 1F Page Data".)

Fixed data-2: Modified data. (Refer to "2. Modification of E, F, 1E, 1F Page Data".)

Address	Initial value	Remark
00 to FF		
10	40	54/66MHz origin osc. adj.
11 to 12		Fixed data-1
13	44	HALL adj.
14	CE	
15	17	
16 to 18		Fixed data-1
19		Fixed data-2
1A	80	AWB & LV standard data input
1B	7A	
1C to 2F		Fixed data-1
30	4D	AWB & LV standard data input
31	3E	
32	64	
33	59	
34	98	Auto white balance adj.
35	75	
36		Fixed data-1
37	3A	Color reproduction adj.
38		Fixed data-1
39	2E	Color reproduction adj.
3A to 3F		Fixed data-1
40	FE	Color reproduction adj.
41	DF	
42 to 43		Fixed data-1
44		Fixed data-2 (Modified data. Copy the data built in the same model.)
45		
46		
47		
48	28	Flange back adj.
49	8E	
4A	34	
4B	69	
4C	11	
4D	64	
4E	00	
4F	00	
50	00	
51	00	
52	2B	
53	19	
54	00	
55	2F	
56	00	
57	00	
58	00	
59 to 71		Fixed data-1
72		Fixed data-2
73		
74 to 75		Fixed data-1
76	40	Mechanical shutter adj.
77	00	
78	34	
79	00	

Address	Initial value	Remark
7A	30	Mechanical shutter adj.
7B	00	
7C	2A	
7D	00	
7E	28	
7F	00	
80	40	
81	3A	
82	31	
83	31	
84	35	
85	1E	
86	80	
87	80	
88	80	
89	80	
8A	80	
8B	80	
8C	03	
8D	80	
8E	80	
8F	80	
90 to 97		Fixed data-1
98		Fixed data-2
99		
9A		
9B		
9C to A8		Fixed data-1
A9		Fixed data-2
AA		Fixed data-1
AB		Fixed data-2
AC to CF		Fixed data-1
D0		Fixed data-2
D1 to D7		Fixed data-1
D8		Fixed data-2 (Modified data. Copy the data built in the same model.)
D9		
DA		
DB		
DC		
DD		
DE		
DF		
E0 to E2		
E3		Fixed data-2
E4		
E5 to F6		Fixed data-1
E7		Fixed data-2
E8 to F4		Fixed data-1
F5		Fixed data-2
F6		Fixed data-1
F7		Fixed data-2 (Modified data. Copy the data built in the same model.)
F8		
F9		
FA		
FB		
FC to FD		Fixed data-1
FE		Fixed data-2
FF		Fixed data-1

Table 5-1-10.

5. 1E Page Table

Note1: When reading or writing the 1E page data, select page: 0, address: 10, and set data: 01, then select E page. The 1E page can be chosen by this data setting.

After reading or writing, reset the data of page: 0, address: 10 to "00".

Note2: Fixed data-1: Initialized data. (Refer to "1. Initializing the E, F, 1E, 1F Page Data".)

Fixed data-2: Modified data. (Refer to "2. Modification of E, F, 1E, 1F Page Data".)

Address	Remark	
	Initial value	
00 to 1F		Fixed data-1
20	00	Black defective CCD adj.
21	00	
22	00	
23	00	
24	00	
25	00	
26	00	
27	00	
28	00	
29	00	
2A	00	
2B	00	
2C	00	
2D	00	
2E	00	
2F	00	

Table. 5-1-11.

6. 1F Page Table

Note1: When reading or writing the 1F page data, select page: 0, address: 10, and set data: 01, then select F page. The 1F page can be chosen by this data setting.

After reading or writing, reset the data of page: 0, address: 10 to "00".

Note2: Fixed data-1: Initialized data. (Refer to "1. Initializing the E, F, 1E, 1F Page Data".)

Fixed data-2: Modified data. (Refer to "2. Modification of E, F, 1E, 1F Page Data".)

Address	Remark	
	Initial value	
00 to 38		Fixed data-1
39		Fixed data-2
3A to 41		Fixed data-1
42		Fixed data-2
43 to 44		Fixed data-1
45		Fixed data-2
46		
47 to 9F		Fixed data-1
A0		Fixed data-2
A1		Fixed data-1
A2		Fixed data-2
A3 to AB		Fixed data-1
AC		Fixed data-2 (Modified data. Copy the data built in the same model.)
AD		
AE		
AF		
B0 to B1		Fixed data-1
B2		Fixed data-2
B3		Fixed data-1
B4		Fixed data-2
B5 to B7		Fixed data-1
B8		Fixed data-2 (Modified data. Copy the data built in the same model.)
B9		
BA		
BB to BD		Fixed data-1
BE		Fixed data-2
BF to C9		Fixed data-1
CA		Fixed data-2
CB		
CC		
CD to CE		Fixed data-1
CF		Fixed data-2
D0 to DC		Fixed data-1
DD		Fixed data-2
DE to E4		Fixed data-1
E5		Fixed data-2
E6 to FF		Fixed data-1

Table. 5-1-12.

1-3. CAMERA SYSTEM ADJUSTMENTS

Before perform the camera system adjustments, check that the specified values of “VIDEO SYSTEM ADJUSTMENTS” are satisfied.

And check that the data of page: 0, address: 10 is “00”. If not, set data: 00 to this address.

1. HALL Adjustment 

For detecting the position of the lens iris, adjust AMP gain and offset.

Subject	Not required
Measurement Point	Display data of page 1 (Note1)
Measuring Instrument	Adjustment remote commander
Adjustment Page	F
Adjustment Address	13, 14, 15
Specified Value 1	15 to 19
Specified Value 2	89 to 8D

Note1: Displayed data of page 1 of the adjustment remote commander.
1 : 00 : XX

IRIS display data

Note2: The data of page: 0, address: 10 must be “00”.

Switch setting:

POWER CAMERA

Adjusting method:

Order	Page	Address	Data	Procedure
1	0	01	01	Set the data.
2	6	94	17	Set the data.
3	6	95	8B	Set the data.
4	6	01	6D	Set the data, and press PAUSE button.
5	6	02		Check that the data changes to “01”. (Note3)
6	6	01	00	Set the data, and press PAUSE button.

Note3: The adjustment data will be automatically input to page: F, address: 13, 14, 15.

Checking method:

Order	Page	Address	Data	Procedure
1	0	03	03	Set the data.
2	6	01	01	Set the data, and press PAUSE button.
3	1			Check that the IRIS display data (Note1) satisfies the specified value 1.
4	6	01	03	Set the data, and press PAUSE button.
5	1			Check that the IRIS display data (Note1) satisfies the specified value.2.

Processing after Completing Adjustments:

Order	Page	Address	Data	Procedure
1	6	94	00	Set the data.
2	6	95	00	Set the data.
3	0	03	00	Set the data.
4	6	01	00	Set the data, and press PAUSE button.
5	0	01	00	Set the data.

2. Flange Back Adjustment (Using Minipattern Box)

The inner focus lens flange back adjustment is carried out automatically. In whichever case, the focus will be deviated during auto focusing/manual focusing.

Subject	Siemens star chart with ND filter for the minipattern box (Note1)
Measuring Instrument	Adjustment remote commander
Adjustment Page	F
Adjustment Address	48 to 58

Note1: Dark Siemens star chart.

Note2: This adjustment should be carried out upon completion of "HALL adjustment".

Note3: Make the lens horizontal and perform this adjustment.

Note4: The data of page: 0, address: 10 must be "00".

Note5: Check that the data of page: 6, address: 02 is "00". If not, set data: 00 to this address, and press the PAUSE button.

Switch setting:

- 1) POWER CAMERA
- 2) NIGHT SHOT OFF
- 3) COLOR SLOW SHUTTER OFF

Preparations:

- 1) The minipattern box is installed as shown in the following figure.
Note: The attachment lenses are not used.
- 2) Install the minipattern box so that the distance between it and the front of the lens of the camcorder is less than 3cm.
- 3) Make the height of the minipattern box and the camcorder equal.
- 4) Check that the output voltage of the regulated power supply is the specified voltage.
- 5) Check that at both the zoom lens TELE end and WIDE end, the center of the Siemens star chart and center of the exposure screen coincide.

Specified voltage: The specified voltage varies according to the minipattern box, so adjust the power supply output voltage to the specified voltage written on the sheet which is supplied with the minipattern box.

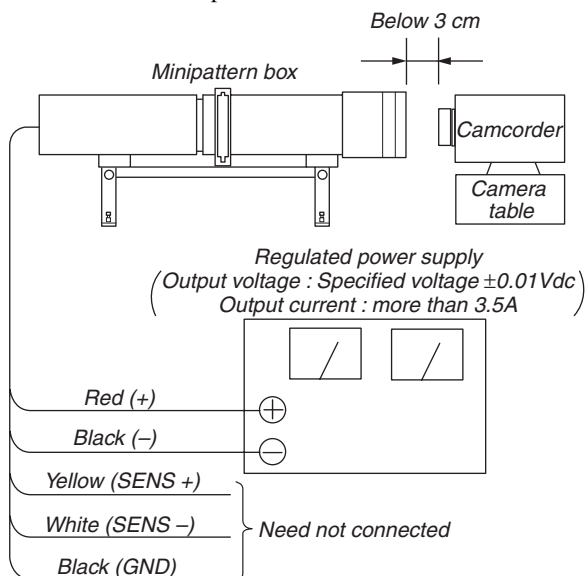

Fig. 5-1-7.

Adjusting method:

Order	Page	Address	Data	Procedure
1	0	01	01	Set the data.
2	6	01	13	Set the data, and press PAUSE button.
3	6	01	27	Set the data, and press PAUSE button.
4	6	02		Check that the data changes to "01". (Note6)

Note6: The adjustment data will be automatically input to page: F, address: 48 to 58.

Processing after Completing Adjustments:

Order	Page	Address	Data	Procedure
1	0	01	00	Set the data.
2				Turn off the power and turn on again.
3				Perform "Flange Back Check".

3. Flange Back Adjustment
(Using Flange Back Adjustment Chart and Subject
More Than 500m Away)

The inner focus lens flange back adjustment is carried out automatically. In whichever case, the focus will be deviated during auto focusing/manual focusing.

3-1. Flange Back Adjustment (1) *RadarW*

Subject	Flange back adjustment chart (2.0 m from the front of the protection glass) (Luminance: 350 ± 50 lux)
Measuring Instrument	Adjustment remote commander
Adjustment Page	F
Adjustment Address	48 to 58

Note1: This adjustment should be carried out upon completion of "HALL adjustment".

Note2: Make the lens horizontal and perform this adjustment.

Note3: The data of page: 0, address: 10 must be "00".

Note4: Check that the data of page: 6, address: 02 is "00". If not, set data: 00 to this address, and press the PAUSE button.

Switch setting:

- 1) POWER CAMERA
- 2) NIGHT SHOT OFF
- 3) COLOR SLOW SHUTTER OFF

Adjusting method:

Order	Page	Address	Data	Procedure
1	0	01	01	Set the data.
2	6	01	13	Set the data, and press PAUSE button.
3	6	01	15	Set the data, and press PAUSE button.
4	6	02		Check that the data changes to "01". (Note5)

Note5: The adjustment data will be automatically input to page: F, address: 48 to 58.

Processing after Completing Adjustments:

Order	Page	Address	Data	Procedure
1				Turn off the power and turn on again.
2				Perform "Flange Back Adjustment (2)"

3-2. Flange Back Adjustment (2) *RadarW*

Perform this adjustment after performing "Flange Back Adjustment (1)".

Subject	Subject more than 500m away (Subjects with clear contrast such as buildings, etc.)
Measurement Point	Check operation on TV monitor
Measuring Instrument	
Adjustment Page	F
Adjustment Address	48 to 58

Note1: Make the lens horizontal and perform this adjustment.

Note2: The data of page: 0, address: 10 must be "00".

Note3: Check that the data of page: 6, address: 02 is "00". If not, set data: 00 to this address, and press the PAUSE button.

Switch setting:

- 1) POWER CAMERA
- 2) NIGHT SHOT OFF
- 3) COLOR SLOW SHUTTER OFF

Preparations:

- 1) Set the zoom lens to the TELE end and expose a subject that is more than 500m away (subject with clear contrast such as building, etc.). (Nearby subjects less than 500m away should not be in the screen.)

Adjusting method:

Order	Page	Address	Data	Procedure
1	0	01	01	Set the data.
2	6	01	13	Set the data, and press PAUSE button.
3				Place a ND filter on the lens so that the optimum image is obtain.
4	6	01	29	Set the data, and press PAUSE button.
5	6	02		Check that the data changes to "01". (Note4)

Note4: The adjustment data will be automatically input to page: F, address: 48 to 58.

Processing after Completing Adjustments:

Order	Page	Address	Data	Procedure
1	0	01	00	Set the data.
2				Turn off the power and turn on again.
3				Perform "Flange Back Check".

4. Flange Back Check

Subject	Siemens star (2.0m from the front of the lens) (Luminance : approx. 200 lux)
Measurement Point	Check operation on TV monitor
Measuring Instrument	
Specified Value	Focused at the TELE end and WIDE end.

Note1: The data of page: 0, address: 10 must be "00".

Switch setting:

- 1) POWER CAMERA
- 2) NIGHT SHOT OFF
- 3) DIGITAL ZOOM (Menu display) OFF
- 4) STEADY SHOT (Menu display) OFF

Note2: When the auto focus is ON, the lens can be checked if it is focused or not by observing the data on the page 1 of the adjustment remote commander.

- 1) Select page: 0, address: 03, and set data: 0F.
- 2) Page 1 shows the state of the focus.

1 : 00 : XX
 └── Odd: Focused
 └── Even: Unfocused

Checking method:

- 1) Place the Siemens star 2.0m from the front of the lens.
- 2) To open the IRIS, decrease the luminous intensity to the Siemens star up to a point before noise appear on the image.
- 3) Shoot the Siemens star with the zoom TELE end.
- 4) Turn on the auto focus.
- 5) Check that the lens is focused (Note2).
- 6) Select page: 6, address: 21, and set data: 10.
- 7) Shoot the Siemens star with the zoom WIDE end.
- 8) Observe the TV monitor and check that the lens is focused.

Processing after Completing Adjustments:

- 1) Select page: 6, address: 21, and set data: 00.
- 2) Select page: 0, address: 03, and set data: 00.

5. Mechanical Shutter Adjustment 

Adjustment Page	F
Adjustment Address	76 to 8F

Note1: The data of page: 0, address: 10 must be "00".

Input method:

- 1) Select page: 0, address: 01, and set data: 01.
- 2) Input the following data to page: F, addresses: 76 to 8F.

Note2: Press the PAUSE button of the adjustment remote commander each time to set the data.

Address	Data
76	40
77	00
78	34
79	00
7A	30
7B	00
7C	2A
7D	00
7E	28
7F	00
80	40
81	3A
82	31
83	31
84	35
85	1E
86	80
87	80
88	80
89	80
8A	80
8B	80
8C	03
8D	80
8E	80
8F	80

- 3) Select page: 0, address: 01, and set data: 00.

6. Black Defective CCD Adjustment *RadarW*

Subject	Clear chart (All white) (Note1) (Approx. 40cm from the front of the lens)
Adjustment Page	1E (Note2)
Adjustment Address	20 to 2F

Note1: Shoot the clear chart with the zoom WIDE end. And adjust the direction of the camera so that the whole of the screen is white.

Note2: When reading or writing the 1E page data, select page: 0, address: 10, and set data: 01, then select E page. The 1E page can be chosen by this data setting.

After reading or writing, reset the data of page: 0, address: 10 to "00".

Note3: This adjustment should be carried out upon completion of the following adjustment.

Flange Back Adjustment

Note4: Check that the data of page: 6, address: 02 is "00". If not, set data: 00 to this address, and press the PAUSE button.

Switch setting:

- 1) POWER CAMERA
- 2) NIGHT SHOT OFF

Adjusting method:

Order	Page	Address	Data	Procedure
1	0	01	01	Set the data.
2	0	10	00	Set the data.
3	6	2C	01	Set the data.
4	6	9C	01	Set the data.
5	6	90	80	Set the data.
6	6	91	01	Set the data.
7	6	92	00	Set the data.
8	6	93	01	Set the data.
9	6	01	79	Set the data, and press PAUSE button.
10	6	01	8D	Set the data, and press PAUSE button.
11	6	02		Check that the data changes to "01". (Note5)

Note5: The adjustment data will be automatically input to page: 1E, address: 20 to 2F.

Processing after Completing Adjustments:

Order	Page	Address	Data	Procedure
1	0	10	00	Set the data.
2	6	01	00	Set the data, and press PAUSE button.
3	6	2C	00	Set the data.
4	6	9C	00	Set the data.
5	6	90	00	Set the data.
6	6	91	00	Set the data.
7	6	92	00	Set the data.
8	6	93	00	Set the data.
9	0	01	00	Set the data.

7. Picture Frame Setting

Subject	Color bar chart (Color reproduction adjustment frame) (1.5m from the front of the lens)
Measurement Point	Video output terminal
Measuring Instrument	Oscilloscope and TV monitor
Specified Value	A=B, C=D, E=F

Note1: The following adjustments should be carried out upon completion of "Flange back adjustment".

Note2: The data of page: 0, address: 10 must be "00".

Switch setting:

- 1) POWER CAMERA
- 2) NIGHT SHOT OFF
- 3) DIGITAL ZOOM (Menu display) OFF
- 4) STEADY SHOT (Menu display) OFF

Setting method:

- 1) Adjust the zoom and the camera direction, and set to the specified position.
- 2) Mark the position of the picture frame on the monitor display, and adjust the picture frame to this position in following adjustments using "Color reproduction adjustment frame".

Check on the oscilloscope

1. Horizontal period

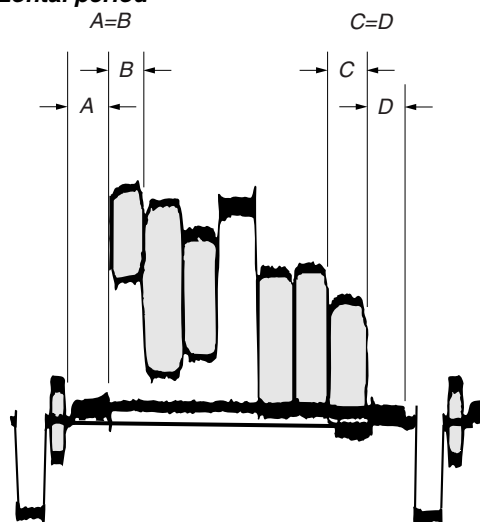

Fig. 5-1-8.

2. Vertical period

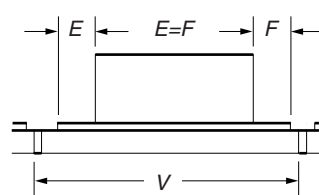

Fig. 5-1-9.

Check on the monitor TV (Underscanned mode)

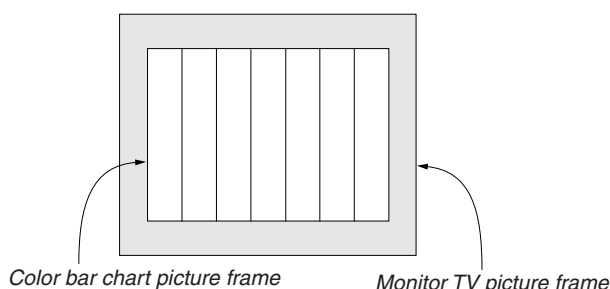

Fig. 5-1-10.

8. Color Reproduction Adjustment

Adjust the color Separation matrix coefficient so that proper color reproduction is produced.

Subject	Color bar chart (Color reproduction adjustment frame)
Measurement Point	Video output terminal
Measuring Instrument	Vectorscope
Adjustment Page	F
Adjustment Address	37, 39, 40, 41
Specified Value	All color luminance points should settle within each color reproduction frame.

Note1: The data of page: 0, address: 10 must be "00".

Note2: NTSC model: DCR-TRV740/TRV840

PAL model: DCR-TRV738E/TRV740E

Switch setting:

- 1) POWER CAMERA
- 2) NIGHT SHOT OFF
- 3) DIGITAL ZOOM (Menu display) OFF
- 4) STEADY SHOT (Menu display) OFF

Adjusting method:

- 1) Select page: 0, address: 01, and set data: 01.
- 2) Select page: 6, address: 9D, set data: 17.
- 3) Select page: 6, address: 01, set data: 3D, and press the PAUSE button.
- 4) Select page: F, address: F0, set following data, and press the PAUSE button.
37 (NTSC), B7 (PAL)
- 5) Adjust the GAIN and PHASE of the vectorscope, and adjust the burst luminance point to the burst position of the color reproduction frame.
- 6) Change the data of page: F, address: 37, 39, 40 and 41, settle each color luminance point in each color reproduction frame.

Note: Be sure to press the PAUSE button of the adjustment remote commander before changing the addresses. If not, the new data will not be written to the memory.

Processing after Completing Adjustments:

- 1) Select page: 6, address: 01, set data: 00, and press the PAUSE button.
- 2) Select page: 6, address: 9D, and set data: 00.
- 3) Select page: 0, address: 01, and set data: 00.

For NTSC model

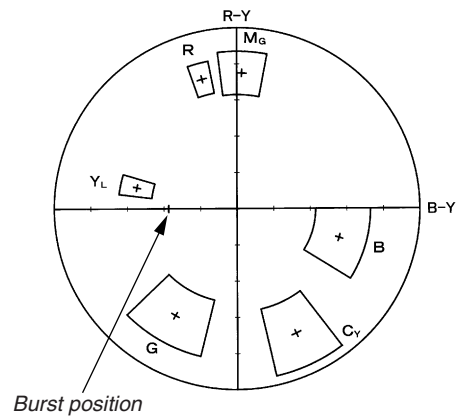

For PAL model

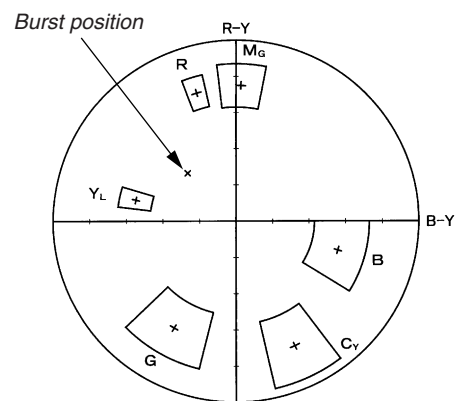

Fig. 5-1-11.

9. Auto White Balance & LV Standard Data Input 

Adjust the white balance reference at 3200K, and adjust the normal coefficient of the light value.

Subject	Clear chart (Color reproduction adjustment frame)
Measurement Point	Display data of page 1 (Note5)
Measuring Instrument	Adjustment remote commander
Adjustment Page	F
Adjustment Address	1A, 1B, 30 to 33
Specified Value	0FF0 to 1010

Note1: This adjustment should be carried out upon completion of “Color reproduction adjustments”.

Note2: After the power is turned on, this adjustment can be done only once.

Note3: The data of page: 0, address: 10 must be “00”.

Note4: Check that the data of page: 6, address: 02 is “00”. If not, set data: 00 to this address, and press the PAUSE button.

Note5: Displayed data of page 1 of the adjustment remote commander.
1 : XX : XX

└─── Display data

Switch setting:

- 1) POWER CAMERA
- 2) NIGHT SHOT OFF
- 3) DIGITAL ZOOM (Menu display) OFF
- 4) STEADY SHOT (Menu display) OFF

Adjusting method:

Order	Page	Address	Data	Procedure
1	0	01	01	Set the data.
2	6	16	02	Set the data.
3				Wait for 2 sec.
4	6	01	11	Set the data, and press PAUSE button.
5	6	01	0D	Set the data, and press PAUSE button.
6	6	02		Check that the data changes to “01”. (Note6)
7	0	03	1E	Set the data.
8	1			Check that the display data (Note5) satisfies the specified value.

Note6: The adjustment data will be automatically input to page: F, address: 1A, 1B, 30 to 33.

Processing after Completing Adjustments

Order	Page	Address	Data	Procedure
1	6	01	00	Set the data, and press PAUSE button.
2	6	16	00	Set the data.
3	0	03	00	Set the data.
4	0	01	00	Set the data.
5				Perform “Auto White Balance Adjustment”.

10. Auto White Balance Adjustment 

Adjust to the proper auto white balance output data.

If it is not correct, auto white balance and color reproducibility will be poor.

Subject	Clear chart (Color reproduction adjustment frame)
Filter	Filter C14 for color temperature correction
Measurement Point	Display data of page 1 (Note4)
Measuring Instrument	Adjustment remote commander
Adjustment Page	F
Adjustment Address	34, 35
Specified Value	R ratio: 2BD8 to 2CD8 B ratio: 5970 to 5A70

Note1: This adjustment should be carried out upon completion of “Auto White Balance & LV Standard Data Input”.

Note2: After the power is turned on, this adjustment can be done only once.

Note3: The data of page: 0, address: 10 must be “00”.

Note4: Displayed data of page 1 of the adjustment remote commander.

1 : XX : XX
 └─── Display data

Switch setting:

- 1) POWER CAMERA
- 2) NIGHT SHOT OFF
- 3) DIGITAL ZOOM (Menu display) OFF
- 4) STEADY SHOT (Menu display) OFF

Adjusting method:

Order	Page	Address	Data	Procedure
1				Place the C14 filter for color temperature correction on the lens.
2	0	01	01	Set the data.
3	F	44		Write down the data.
4	F	44	2C	Set the data, and press PAUSE button.
5	F	45		Write down the data.
6	F	45	58	Set the data, and press PAUSE button.
7	F	46		Write down the data.
8	F	46	59	Set the data, and press PAUSE button.
9	F	47		Write down the data.
10	F	47	F0	Set the data, and press PAUSE button.
11	6	01	83	Set the data, and press PAUSE button.
12	6	01	81	Set the data, and press PAUSE button.
13	6	02		Check that the data changes to “01”. (Note5)
14	6	01	3F	Set the data, and press PAUSE button.
15	0	03	04	Set the data.
16	1			Check that the display data (Note4) satisfies the R ratio specified value.
17	0	03	05	Set the data.
18	1			Check that the display data (Note4) satisfies the B ratio specified value.

Note5: The adjustment data will be automatically input to page: F, address: 34, 35.

Processing after Completing Adjustments:

Order	Page	Address	Data	Procedure
1	6	01	00	Set the data, and press PAUSE button.
2	F	44		Set the data that is written down at step 3, and press PAUSE button.
3	F	45		Set the data that is written down at step 5, and press PAUSE button.
4	F	46		Set the data that is written down at step 7, and press PAUSE button.
5	F	47		Set the data that is written down at step 9, and press PAUSE button.
6	0	03	00	Set the data.
7	0	01	00	Set the data.

11. White Balance Check **RadarW**

Subject	Clear chart (Color reproduction adjustment frame)
Filter	Filter C14 for color temperature correction ND filter 1.0 and 0.4 and 0.1
Measurement Point	Video output terminal
Measuring Instrument	Vectorscope
Specified Value	Fig. 5-1-12. A to B

Note: The data of page: 0, address: 10 must be "00".

Switch setting:

- 1) POWER CAMERA
- 2) NIGHT SHOT OFF
- 3) DIGITAL ZOOM (Menu display) OFF
- 4) STEADY SHOT (Menu display) OFF

Checking method:

Order	Page	Address	Data	Procedure
Indoor white balance check				
1				Check that the lens is not covered with either filter.
2	6	01	0F	Set the data, and press PAUSE button.
3				Check that the center of the white luminance point is within the circle shown Fig. 5-1-12. A.
4	6	01	00	Set the data, and press PAUSE button.
Outdoor white balance check				
5				Place the C14 filter on the lens.
6	6	01	3F	Set the data, and press PAUSE button.
7				Check that the center of the white luminance point is within the circle shown Fig. 5-1-12. B.
8				Remove the C14 filter.
LV data check				
9				Place the ND filter 1.5 (1.0 + 0.1 + 0.4) on the lens.
10	6	01	00	Set the data, and press PAUSE button.
11	0	03	06	Set the data.
12	1			Check that the display data (Note) satisfies the specified value. Specified value: 8000 to 8BC0

Note: Displayed data of the adjustment remote commander.

1 : XX:XX
 └───┬─── Display data

Processing after Completing Adjustments

Order	Page	Address	Data	Procedure
1	6	01	00	Set the data, and press PAUSE button.
2	0	03	00	Set the data.

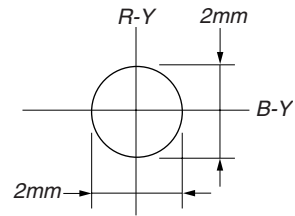

Fig. 5-1-12. (A)

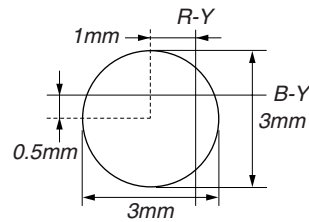

Fig. 5-1-12. (B)

12. Steady Shot Check **Precautions on the Parts Replacement**

There are two types of repair parts.

Type A: ENC03JA

Type B: ENC03JB

Replace the broken sensor with a same type sensor. If replace with other type parts, the image will vibrate up and down or left and right during hand-shake correction operations.

Precautions on Angular Velocity Sensor

The sensor incorporates a precision oscillator. Handle it with care as if it dropped, the balance of the oscillator will be disrupted and operations will not be performed properly.

Subject	Arbitrary
Measurement Point	Display data of page 1 (Note1)
Measuring Instrument	Adjustment remote commander
Specified Value	2B00 to 4B00

Note1: Displayed data of the adjustment remote commander.

1 : XX : XX

Display data

Note2: The data of page: 0, address: 10 must be "00".

Switch setting:

- 1) STEADY SHOT (Menu display) ON
- 2) ZOOM TELE end

Adjusting method:

Order	Page	Address	Data	Procedure
				Pitch sensor check (SI-032 board SE301)
1	0	03	11	Set the data.
2	1			Check that the display data (Note1) satisfies the specified value. Specified value: 2B00 to 4B00
				Yaw sensor check (SI-032 board SE302)
3	0	03	12	Set the data.
4	1			Check that the display data (Note1) satisfies the specified value. Specified value: 2B00 to 4B00

Processing after Completing Adjustments

Order	Page	Address	Data	Procedure
1	0	03	00	Set the data.
2				Move the camcorder, and check that the steady shot operations have been performed normally.

1-4. ELECTRONIC VIEWFINDER SYSTEM ADJUSTMENT

Note1: When replacing the LCD unit, be careful to prevent damages caused by static electricity.

Note2: Before performing the adjustments, check the data of page: 0, address: 10 is "00". If not, set data: 00 to this address.

Note3: Switch setting:
LCD panel Close

Note4: NTSC model: DCR-TRV740/TRV840
PAL model: DCR-TRV738E/TRV740E

[Adjusting connector]

Most of the measuring points for adjusting the viewfinder system are concentrated in CN1108 of VC-278 board.

Connect the Measuring Instruments via the CPC-13 jig (J-6082-443-A).

The following table shows the Pin No. and signal name of CN1108.

Pin No.	Signal Name	Pin No.	Signal Name
1	REG GND	11	VCO
2	N. C.	12	EVF VG
3	BPF MONI	13	RF SWP
4	N. C.	14	N. C.
5	PB RF	15	CAP FG
6	REG GND	16	RF MON
7	N. C.	17	N. C.
8	RF SWP	18	REG GND
9	N. C.	19	REG GND
10	N. C.	20	REG GND

Table 5-1-13.

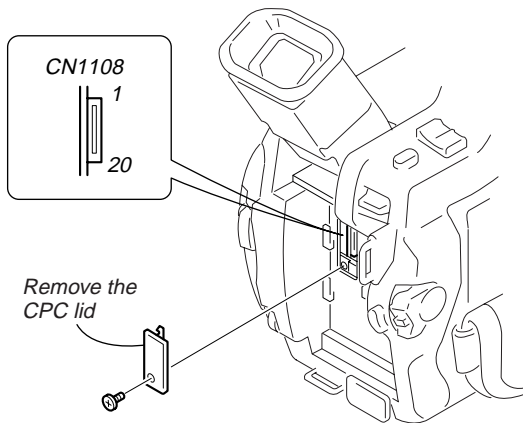

Fig. 5-1-13.

1. VCO Adjustment (VC-278 board)

Set the VCO free-run frequency. If deviated, the EVF screen will be blurred.

Mode	Camera
Subject	Arbitrary
Measurement Point	Pin ⑩ of CN1108 (VCO)
Measuring Instrument	Frequency counter
Adjustment Page	C
Adjustment Address	51, 52
Specified Value	f = 15734 ± 30Hz (NTSC) f = 15625 ± 30Hz (PAL)

Note1: The data of page: 0, address: 10 must be "00".

Adjusting method:

Order	Page	Address	Data	Procedure
1	0	01	01	Set the data.
2	C	51		Change the data and set the VCO frequency (f) to the specified value.
3	C	51		Press PAUSE button.
4	C	51		Read the data, and this data is named D ₅₁ .
5				Convert D ₅₁ to decimal notation, and obtain D ₅₁ '. (Note1)
6				Calculate D ₅₂ ' using following equations (Decimal calculation) [NTSC model] When D ₅₁ ' ≤ 236 D ₅₂ ' = D ₅₁ ' + 19 When D ₅₁ ' > 236 D ₅₂ ' = 255 [PAL model] When D ₅₁ ' ≥ 19 D ₅₂ ' = D ₅₁ ' - 19 When D ₅₁ ' < 19 D ₅₂ ' = 00
7				Convert D ₅₂ ' to a hexadecimal number, and obtain D ₅₂ . (Note)
8	C	52	D ₅₂	Set the data, and press PAUSE button.
9	0	01	00	Set the data.

Note2: Refer to "Table 5-4-1. Hexadecimal-decimal Conversion Table".

2. RGB AMP Adjustment (VC-278 board)

Set the D range of the RGB driver used to drive the LCD to the specified value. If deviated, the LCD screen will become blackish or saturated (whitish).

Mode	Camera
Subject	Arbitrary
Measurement Point	Pin ⑫ of CN1108 (EVF VG)
Measuring Instrument	Oscilloscope
Adjustment Page	C
Adjustment Address	54
Specified Value	A = $7.50 \pm 0.10\text{V}$ (NTSC) A = $7.52 \pm 0.10\text{V}$ (PAL)

Note: The data of page: 0, address: 10 must be "00".

Adjusting method:

Order	Page	Address	Data	Procedure
1	0	01	01	Set the data.
2	C	54		Change the data and set the voltage (A) between the reversed waveform pedestal and non-reversed waveform pedestal to the specified value.
3	C	54		Press PAUSE button.
4	0	01	00	Set the data.

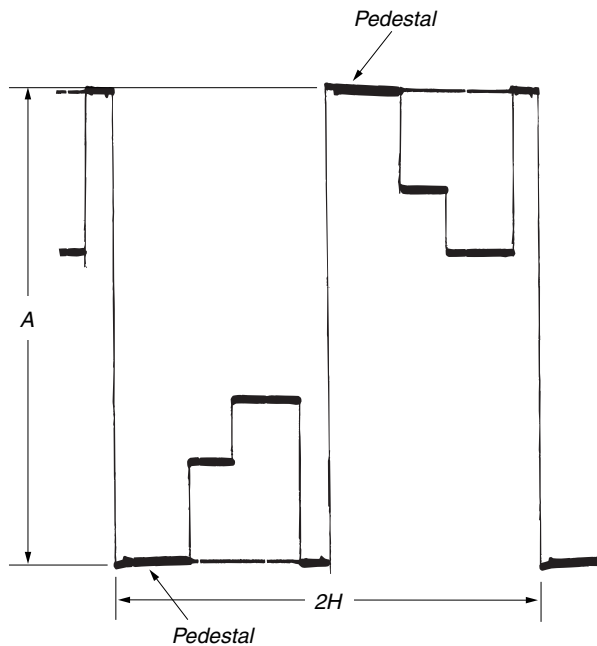

Fig. 5-1-14.

3. Contrast Adjustment (VC-278 board)

Set the level of the VIDEO signal for driving the LCD to the specified value. If deviated, the screen image will be blackish or saturated (whitish).

Mode	Camera
Subject	Arbitrary
Measurement Point	Pin ⑫ of CN1108 (EVF VG)
Measuring Instrument	Oscilloscope
Adjustment Page	C
Adjustment Address	58
Specified Value	A = $2.49 \pm 0.10\text{V}$ (NTSC) A = $2.42 \pm 0.10\text{V}$ (PAL)

Note: The data of page: 0, address: 10 must be "00".

Adjusting method:

Order	Page	Address	Data	Procedure
1	0	01	01	Set the data.
2	C	58		Change the data and set the voltage (A) between the 100 IRE and 0 IRE (pedestal) to the specified value. (The data should be "00" to "7F".)
3	C	58		Press PAUSE button.
4	0	01	00	Set the data.

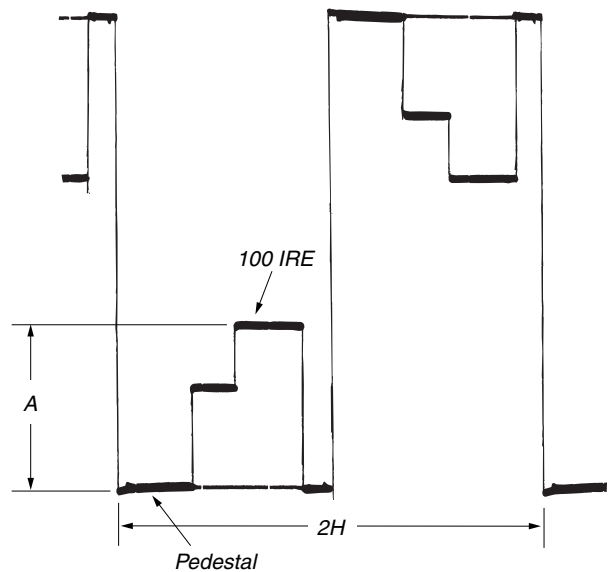

Fig. 5-1-15.

1-5. LCD SYSTEM ADJUSTMENT

Note1: The back light (fluorescent tube) is driven by a high voltage AC power supply. Therefore, do not touch the back light holder to avoid electrical shock.

Note2: When replacing the LCD unit, be careful to prevent damages caused by static electricity.

Note3: Before performing the adjustments, check the data of page: 0, address: 10 is "00". If not, set data: 00 to this address.

Note4: Set the LCD BRIGHT (Menu display) to the center.
Set the LCD COLOR (Menu display) to the center.

[Adjusting connector]

Most of the measuring points for adjusting the LCD system are concentrated in CN5502 of the PD-156/160 board. Connect the measuring instruments via the multi CPC jig (J-6082-311-A). The following table shows the Pin No. and signal name of CN5502.

PD-156 board

Pin No.	Signal Name	Pin No.	Signal Name
1	VB	2	XVD OUT
3	VG	4	PANEL COM
5	VR	6	PANEL ID
7	C-SYNC/XHD	8	XHD OUT
9	GND	10	GND

Table 5-1-14.

PD-160 board

Pin No.	Signal Name	Pin No.	Signal Name
1	VB	2	XVD OUT
3	VG	4	PSIG
5	VR	6	MAKER CHECK
7	XHD	8	XHD OUT
9	GND	10	GND

Table 5-1-15.

PD-156/160 board

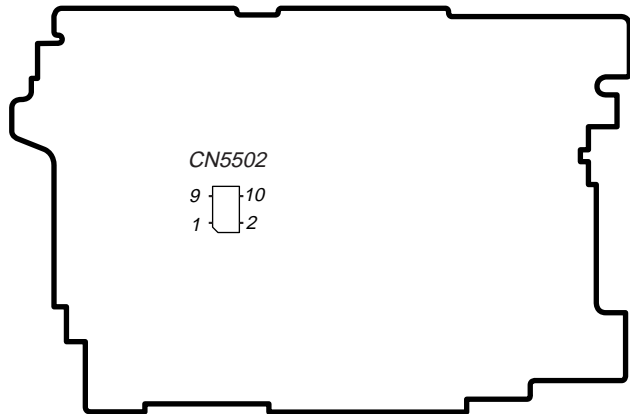

1-5-1. LCD Type Check

By measuring the resistor value between Pin ⑥ of CN5502 and GND, the type of LCD can be discriminated.

Resistor value	LCD type	PD board	DCR-
2.2kΩ	2.5 LCD TYPE SH (123k)	PD-156	TRV738E TRV740E *1
6.8kΩ	3.5 LCD TYPE CA (123k)	PD-156	TRV840
22kΩ	2.5 LCD TYPE SO (61k)	PD-160	TRV740 TRV740E *2
47kΩ	3.5 LCD TYPE SO (123k)	PD-160	TRV840

*1: AEP/EE/NE/RU model

*2: E/AUS/HK/CH/JE model

When the type of LCD is "LCD TYPE CA" or "LCD TYPE SH", perform "1-5-2. LCD SYSTEM ADJUSTMENT (PD-156 board)"

When the type of LCD is "LCD TYPE SO", perform "1-5-3. LCD SYSTEM ADJUSTMENT (PD-160 board)"

- Abbreviation
 HK : Hong Kong model
 AUS : Australian model
 CH : Chinese model
 JE : Tourist model
 EE : East European model
 NE : North European model
 RU : Russian model

1-5-2. LCD SYSTEM ADJUSTMENT (PD-156 board)**1. VCO Adjustment (PD-156 board)**

Set the VCO free-run frequency. If deviated, the LCD screen will be blurred.

Mode	VTR stop
Signal	No signal
Measurement Point	Pin ⑧ of CN5502 (XHD OUT)
Measuring Instrument	Frequency counter
Adjustment Page	C
Adjustment Address	61, 62
Specified Value	f = 15734 ± 30Hz (NTSC) f = 15625 ± 30Hz (PAL)

Note1: NTSC model: DCR-TRV840

PAL model: DCR-TRV738E/TRV740E

Note2: Refer to "LCD Type Check" for the discrimination of the LCD type.

Note3: The data of page: 0, address: 10 must be "00".

Adjusting method:

Order	Page	Address	Data	Procedure
1	0	01	01	Set the data.
2	C	61		Change the data and set the VCO frequency (f) to the specified value.
3	C	61		Press PAUSE button.
4	C	61		Read the data, and this data is named D ₆₁ .
5				Convert D ₆₁ to decimal notation, and obtain D ₆₁ ' (Note2)
6				Calculate D ₆₂ ' using following equations (Decimal calculation) [NTSC 3.5 LCD TYPE CA] When D ₆₁ ' ≤ 252 D ₆₂ ' = D ₆₁ ' + 3 When D ₆₁ ' > 252 D ₆₂ ' = 255 [PAL 2.5 LCD TYPE SH] When D ₆₁ ' ≥ 20 D ₆₂ ' = D ₆₁ ' - 20 When D ₆₁ ' < 20 D ₆₂ ' = 0
7				Convert D ₆₂ ' to a hexadecimal number, and obtain D ₆₂ . (Note4)
8	C	62	D ₆₂	Set the data, and press PAUSE button.
9	0	01	00	Set the data.

Note4: Refer to "Table 5-4-1. Hexadecimal-decimal Conversion Table".

2. RGB AMP Adjustment (PD-156 board)

Set the D range of the RGB decoder used to drive the LCD to the specified value. If deviated, the LCD screen will become blackish or saturated (whitish).

Mode	VTR stop
Signal	No signal
Measurement Point	Pin ③ of CN5502 (VG) Ext. trigger: Pin ④ of CN5502 (PANEL COM)
Measuring Instrument	Oscilloscope
Adjustment Page	C
Adjustment Address	64
Specified Value	NTSC 3.5 LCD TYPE CA: A = 3.22 ± 0.05V PAL 2.5 LCD TYPE SH: A = 3.55 ± 0.05V

Note1: NTSC model: DCR-TRV840

PAL model: DCR-TRV738E/TRV740E

Note2: Refer to "LCD Type Check" for the discrimination of the LCD type.

Note3: The data of page: 0, address: 10 must be "00".

Adjusting method:

Order	Page	Address	Data	Procedure
1	0	01	01	Set the data.
2	C	64		Change the data and set the voltage (A) between the reversed waveform pedestal and non-reversed waveform pedestal to the specified value. (The data should be "00" to "3F".)
3	C	64		Press PAUSE button.
4	0	01	00	Set the data.

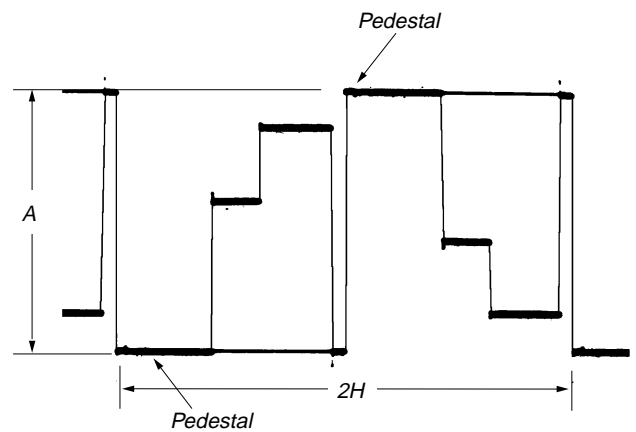

Fig. 5-1-16.

3. Contrast Adjustment (PD-156 board)

Set the level of the VIDEO signal for driving the LCD to the specified value. If deviated, the screen image will be blackish or saturated (whitish).

Mode	VTR stop
Signal	No signal
Measurement Point	Pin ③ of CN5502 (VG) Ext. trigger: Pin ④ of CN5502 (PANEL COM)
Measuring Instrument	Oscilloscope
Adjustment Page	C
Adjustment Address	69
Specified Value	NTSC 3.5 LCD TYPE CA: A = 3.18 ± 0.05V PAL 2.5 LCD TYPE SH: A = 3.19 ± 0.05V

Note1: NTSC model: DCR-TRV840

PAL model: DCR-TRV738E/TRV740E

Note2: Refer to "LCD Type Check" for the discrimination of the LCD type.

Note3: The data of page: 0, address: 10 must be "00".

Adjusting method:

Order	Page	Address	Data	Procedure
1	0	01	01	Set the data.
2	C	69		Change the data and set the voltage (A) between the 100 IRE and 0 IRE (pedestal) to the specified value. (The data should be "00" to "7F".)
3	C	9		Press PAUSE button.
4	0	01	00	Set the data.

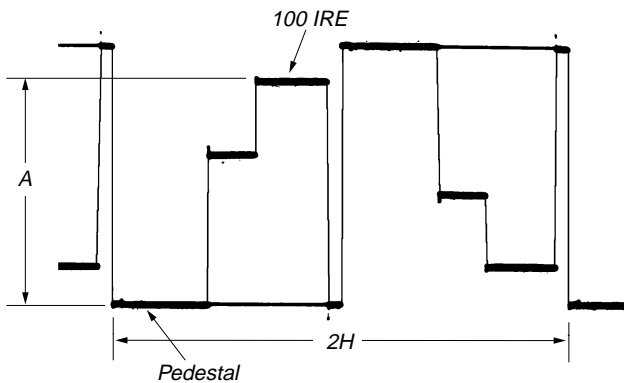

Fig. 5-1-17.

4. COM AMP Adjustment (PD-156 board)

Set the common electrode drive signal level of LCD to the specified value.

Mode	VTR stop
Signal	No signal
Measurement Point	Pin ④ of CN5502 (PANEL COM)
Measuring Instrument	Oscilloscope
Adjustment Page	C
Adjustment Address	66
Specified Value	NTSC 3.5 LCD TYPE CA: A = 5.80 ± 0.05V PAL 2.5 LCD TYPE SH: A = 6.16 ± 0.05V

Note1: NTSC model: DCR-TRV840

PAL model: DCR-TRV738E/TRV740E

Note2: Refer to "LCD Type Check" for the discrimination of the LCD type.

Note3: The data of page: 0, address: 10 must be "00".

Adjusting method:

Order	Page	Address	Data	Procedure
1	0	01	01	Set the data.
2	C	66		Change the data and set the PANEL COM signal level (A) to the specified value.
3	C	66		Press PAUSE button.
4	0	01	00	Set the data.

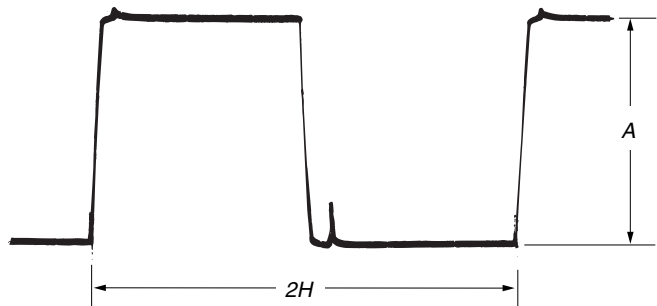

Fig. 5-1-18.

5. V-COM Adjustment (PD-156 board)

Set the DC bias of the common electrode drive signal of LCD to the specified value.

If deviated, the LCD display will move, producing flicker and conspicuous vertical lines.

Mode	VTR stop
Signal	No signal
Measurement Point	Check on LCD display
Measuring Instrument	
Adjustment Page	C
Adjustment Address	63
Specified Value	The brightness difference between the section A and section B is minimum.

Note1: This adjustment should be carried out upon completion of the following adjustments.
 RGB AMP Adjustment
 Contrast Adjustment
 COM AMP Adjustment

Note2: The data of page: 0, address: 10 must be "00".

Adjusting method:

Order	Page	Address	Data	Procedure
1	0	01	01	Set the data.
2	C	63		Change the data so that the brightness of the section A and that of the section B is equal.
3	C	63		Subtract 8 from the data.
4	C	63		Press PAUSE button.
5	0	01	00	Set the data.

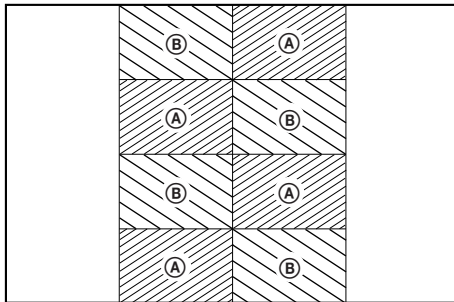

Fig. 5-1-19.

6. White Balance Adjustment (PD-156 board)

Correct the white balance.

If deviated, the reproduction of the LCD screen may degenerate.

Mode	VTR stop
Signal	No signal
Measurement Point	Check on LCD screen
Measuring Instrument	
Adjustment Page	C
Adjustment Address	67, 68
Specified Value	The LCD screen should not be colored.

Note1: Check the white balance only when replacing the following parts.
 If necessary, adjust them.

1. LCD panel
2. Light induction plate
3. IC5501

Note2: The data of page: 0, address: 10 must be "00".

Adjusting method:

Order	Page	Address	Data	Procedure
1	0	01	01	Set the data.
2	C	67		Set the following data, and press PAUSE button. 55 (NTSC 3.5 LCD TYPE CA) 84 (PAL 2.5 LCD TYPE SH)
3	C	68		Set the following data, and press PAUSE button. 3F (NTSC 3.5 LCD TYPE CA) 5F (PAL 2.5 LCD TYPE SH)
4	C	68		Check that the LCD screen is not colored. If not colored, proceed to step 10.
5	C	67		Change the data so that the LCD screen is not colored.
6	C	67		Press PAUSE button.
7	C	68		Change the data so that the LCD screen is not colored.
8	C	68		Press PAUSE button.
9	C	68		If the LCD screen is colored, repeat steps 5 to 9.
10	0	01	00	Set the data.

1-5-3. LCD SYSTEM ADJUSTMENT (PD-160 board)

1. VCO Adjustment (PD-160 board)

Set the VCO free-run frequency. If deviated, the LCD screen will be blurred.

Mode	VTR stop
Signal	No signal
Measurement Point	Pin ⑧ of CN5502 (XHD OUT)
Measuring Instrument	Frequency counter
Adjustment Page	C
Adjustment Address	61, 62
Specified Value	f = 15734 ± 30Hz (NTSC) f = 15625 ± 30Hz (PAL)

Note1: NTSC model: DCR-TRV740/TRV840
PAL model: DCR-TRV740E

Note2: The data of page: 0, address: 10 must be "00".

Adjusting method:

Order	Page	Address	Data	Procedure
1	0	01	01	Set the data.
2	C	61		Change the data and set the VCO frequency (f) to the specified value.
3	C	61		Press PAUSE button.
4	C	61		Read the data, and this data is named D ₆₁ .
5				Convert D ₆₁ to decimal notation, and obtain D ₆₁ '. (Note2)
6				Calculate D ₆₂ ' using following equations (Decimal calculation) [NTSC 2.5 LCD] When D ₆₁ ' ≤ 238 D ₆₂ ' = D ₆₁ ' + 17 When D ₆₁ ' > 238 D ₆₂ ' = 255 [NTSC 3.5 LCD] When D ₆₁ ' ≤ 247 D ₆₂ ' = D ₆₁ ' + 8 When D ₆₁ ' > 247 D ₆₂ ' = 255 [PAL 2.5 LCD] When D ₆₁ ' ≥ 17 D ₆₂ ' = D ₆₁ ' - 17 When D ₆₁ ' < 17 D ₆₂ ' = 0
7				Convert D ₆₂ ' to a hexadecimal number, and obtain D ₆₂ . (Note3)
8	C	62	D ₆₂	Set the data, and press PAUSE button.
9	0	01	00	Set the data.

Note3: Refer to "Table 5-4-1. Hexadecimal-decimal Conversion Table".

2. PSIG Gray Adjustment (PD-160 board)

Set the uniformity improvement signal to an appropriate level.

Mode	VTR stop
Signal	No signal
Measurement Point	Pin ④ of CN5502 (PSIG)
Measuring Instrument	Oscilloscope
Adjustment Page	C
Adjustment Address	66
Specified Value	A = 5.00 ± 0.1V

Note: The data of page: 0, address: 10 must be "00".

Adjusting method:

Order	Page	Address	Data	Procedure
1	0	01	01	Set the data.
2	C	66		Change the data and set the PSIG signal level (A) to the specified value. (The data should be "00" to "7F")
3	C	66		Press PAUSE button.
4	0	01	00	Set the data.

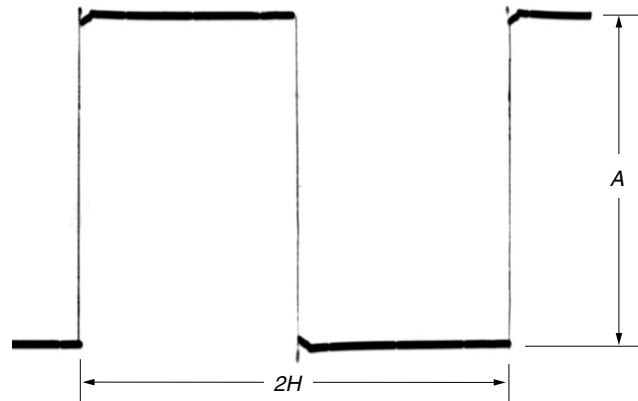

Fig. 5-1-20.

3. RGB AMP Adjustment (PD-160 board)

Set the D range of the RGB decoder used to drive the LCD to the specified value. If deviated, the LCD screen will become blackish or saturated (whitish).

Mode	VTR stop
Signal	No signal
Measurement Point	Pin ③ of CN5502 (VG) Ext. trigger: Pin ④ of CN5502 (PSIG)
Measuring Instrument	Oscilloscope
Adjustment Page	C
Adjustment Address	64
Specified Value	NTSC 2.5 LCD: A = $7.68 \pm 0.05V$ NTSC 3.5 LCD: A = $7.48 \pm 0.05V$ PAL 2.5 LCD: A = $7.62 \pm 0.05V$

Note1: NTSC model: DCR-TRV740/TRV840
PAL model: DCR-TRV740E

Note2: The data of page: 0, address: 10 must be "00".

Adjusting method:

Order	Page	Address	Data	Procedure
1	0	01	01	Set the data.
2	C	64		Change the data and set the voltage (A) between the reversed waveform pedestal and non-reversed waveform pedestal to the specified value.
3	C	64		Press PAUSE button.
4	0	01	00	Set the data.

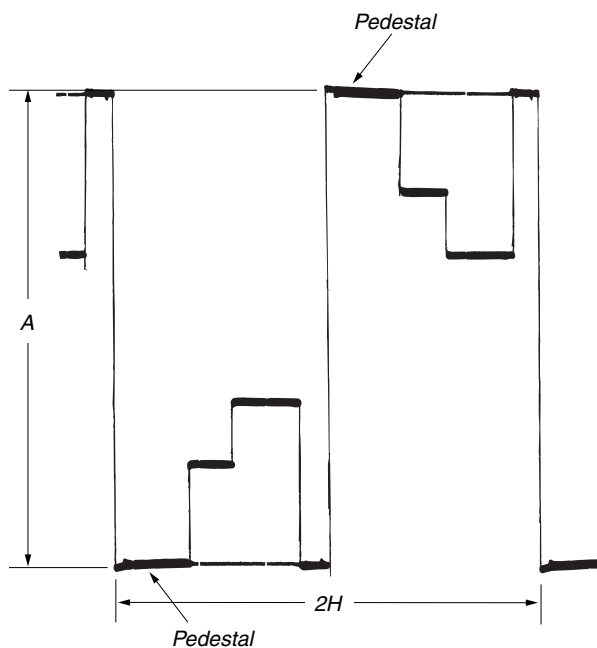

Fig. 5-1-21.

4. Black Limit Adjustment (PD-160 board)

Set the dynamic range of the LCD driver to an appropriate level. If deviated, the LCD screen will become blackish or saturated (whitish).

Mode	VTR stop
Signal	No signal
Measurement Point	Pin ④ of CN5502 (PSIG)
Measuring Instrument	Oscilloscope
Adjustment Page	C
Adjustment Address	65
Specified Value	A = $8.30 \pm 0.08V$

Note: The data of page: 0, address: 10 must be "00".

Adjusting method:

Order	Page	Address	Data	Procedure
1	0	01	01	Set the data.
2	3	C4	61	Set the data.
3	3	C5		Set the following data. 58 (NTSC), 50 (PAL)
4	C	65		Change the data and set the PSIG signal amplitude (A) to the specified value. (The data should be "00" to "0F".)
5	C	65		Press PAUSE button.
6	3	C4	00	Set the data.
7	3	C5	00	Set the data.
8	0	01	00	Set the data.
9				Check that the specified value of "RGB AMP Adjustment" is satisfied.

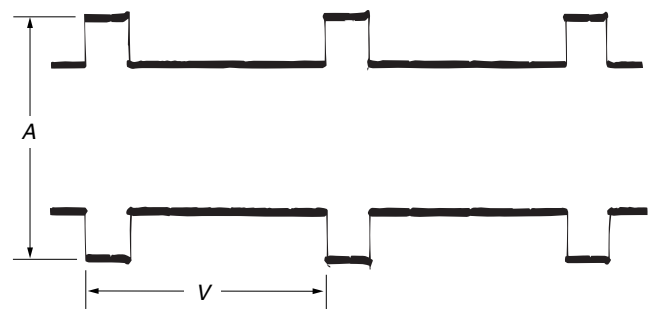

Fig. 5-1-22.

5. Contrast Adjustment (PD-160 board)

Set the level of the VIDEO signal for driving the LCD to the specified value. If deviated, the screen image will be blackish or saturated (whitish).

Mode	VTR stop
Signal	No signal
Measurement Point	Pin ③ of CN5502 (VG) Ext. trigger: Pin ④ of CN5502 (PSIG)
Measuring Instrument	Oscilloscope
Adjustment Page	C
Adjustment Address	69
Specified Value	NTSC 2.5 LCD: A = $2.72 \pm 0.05V$ NTSC 3.5 LCD: A = $2.60 \pm 0.05V$ PAL 2.5 LCD: A = $3.19 \pm 0.05V$

Note1: NTSC model: DCR-TRV740/TRV840
PAL model: DCR-TRV740E

Note2: The data of page: 0, address: 10 must be "00".

Adjusting method:

Order	Page	Address	Data	Procedure
1	0	01	01	Set the data.
2	C	69		Change the data and set the voltage (A) between the 100 IRE and 0 IRE (pedestal) to the specified value. (The data should be "00" to "7F".)
3	C	69		Press PAUSE button.
4	0	01	00	Set the data.

6. Center Level Adjustment (PD-160 board)

Set the video signal center level of LCD panel to an appropriate level.

Mode	VTR stop
Signal	No signal
Measurement Point	Pin ③ of CN5502 (VG)
Measuring Instrument	Digital voltmeter
Adjustment Page	C
Adjustment Address	6A
Specified Value	A = $7.00 \pm 0.03Vdc$

Note: The data of page: 0, address: 10 must be "00".

Adjusting method:

Order	Page	Address	Data	Procedure
1	0	01	01	Set the data.
2	C	6A		Change the data and set the DC voltage (A) to the specified value. (The data should be "00" to "7F".)
3	C	6A		Press PAUSE button.
4	0	01	00	Set the data.

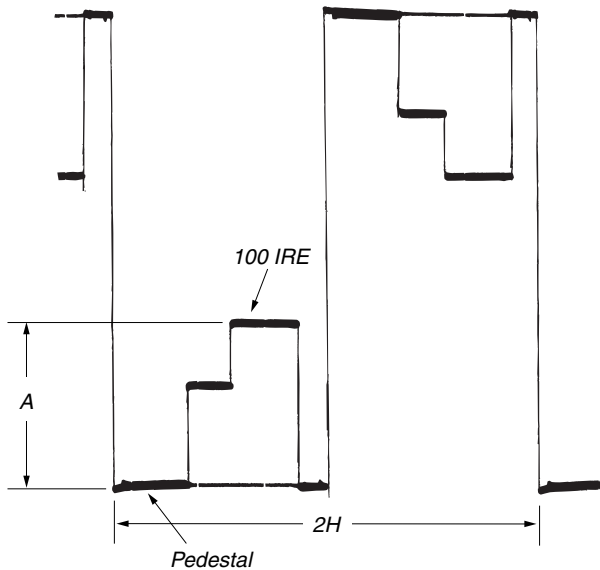

Fig. 5-1-23.

7. V-COM Adjustment (PD-160 board)

Set the DC bias of the common electrode drive signal of LCD to the specified value.

If deviated, the LCD display will move, producing flicker and conspicuous vertical lines.

Mode	VTR stop
Signal	No signal
Measurement Point	Check on LCD display
Measuring Instrument	
Adjustment Page	C
Adjustment Address	63
Specified Value	The brightness difference between the section A and section B is minimum.

Note1: This adjustment should be carried out upon completion of the following adjustments.

- RGB AMP Adjustment
- Black Limit Adjustment
- Contrast Adjustment
- Center Level Adjustment

Note2: The data of page: 0, address: 10 must be "00".

Adjusting method:

Order	Page	Address	Data	Procedure
1	0	01	01	Set the data.
2	C	63		Change the data so that the brightness of the section A and that of the section B is equal. (The data should be "00" to "3F".)
3	C	63		Subtract 2 from the data.
4	C	63		Press PAUSE button.
5	0	01	00	Set the data.

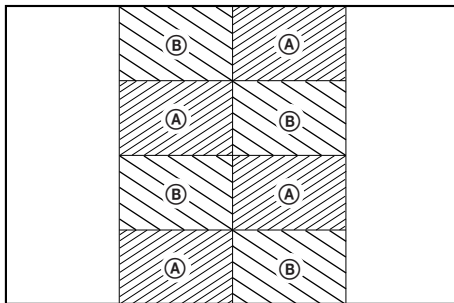

Fig. 5-1-24.

8. White Balance Adjustment (PD-160 board)

Correct the white balance.

If deviated, the reproduction of the LCD screen may degenerate.

Mode	VTR stop
Signal	No signal
Measurement Point	Check on LCD screen
Measuring Instrument	
Adjustment Page	C
Adjustment Address	67, 68
Specified Value	The LCD screen should not be colored.

Note1: Check the white balance only when replacing the following parts. If necessary, adjust them.

1. LCD panel
2. Light induction plate
3. IC5501

Note2: The data of page: 0, address: 10 must be "00".

Adjusting method:

Order	Page	Address	Data	Procedure
1	0	01	01	Set the data.
2	C	67		Set the following data, and press PAUSE button. 7E (NTSC 2.5 LCD) 7E (NTSC 3.5 LCD) 81 (PAL 2.5 LCD)
3	C	68		Set the following data, and press PAUSE button. 6C (NTSC 2.5 LCD) 78 (NTSC 3.5 LCD) 6F (PAL 2.5 LCD)
4	C	68		Check that the LCD screen is not colored. If not colored, proceed to step 10.
5	C	67		Change the data so that the LCD screen is not colored.
6	C	67		Press PAUSE button.
7	C	68		Change the data so that the LCD screen is not colored.
8	C	68		Press PAUSE button.
9	C	68		If the LCD screen is colored, repeat steps 5 to 9.
10	0	01	00	Set the data.

5-2. MECHANISM SECTION ADJUSTMENT

Mechanism Section adjustments, checks, and replacement of mechanism parts, refer to the separate volume "8mm Video Mechanism Adjustment Manual [M2000 Mechanism]".

2-1. Hi8/STANDARD 8 MODE

Note1: Before performing the adjustments, check the data of page: 0, address: 10 is "00". If not, set data: 00 to this address.

2-1-1. OPERATING WITHOUT CASSETTE

- 1) Refer to "Section 2. DISASSEMBLY" and supply the power with the cabinet assembly removed. (So that the mechanical deck can be operated.)
- 2) Connect the adjustment remote commander to the LANC jack.
- 3) Turn on the HOLD switch of the adjustment remote commander.
- 4) Close the cassette compartment without loading a cassette and complete loading.
- 5) Select page: 0, address: 01, and set data: 01.
- 6) Select page: C, address: 3E, set data: 01, and press the PAUSE button of the adjustment remote commander.
- 7) Select page: A, address: 10, set data: 10, and press the PAUSE button.
- 8) Disconnect the power supply of the unit, and connect it again.
- 9) Select page: 7, address: 62, and set data: 02.

By carrying out the above procedure, the unit can be operated without loading a cassette. (Note2)

Be sure to carry out "Processing after Operations" after checking the operations.

Set the data of page: D, address: 10 to "02", if the sensor ineffective mode, forced VTR power supply ON mode is to be used together.

Note2: Except for the camera recording mode and VTR recording mode.

[Procedure after checking operations]

- 1) Select page: 0, address: 01, and set data: 01.
- 2) Select page: C, address: 3E, set data: 00, and press the PAUSE button.
- 3) Select page: D, address: 10, set data: 00, and press the PAUSE button.
- 4) Select page: A, address: 10, set data: 00, and press the PAUSE button.
- 5) Select page: 7, address: 62, and set data: 00.
- 6) Select page: 0, address: 01, and set data: 00.
- 7) Disconnect the power supply of the unit.

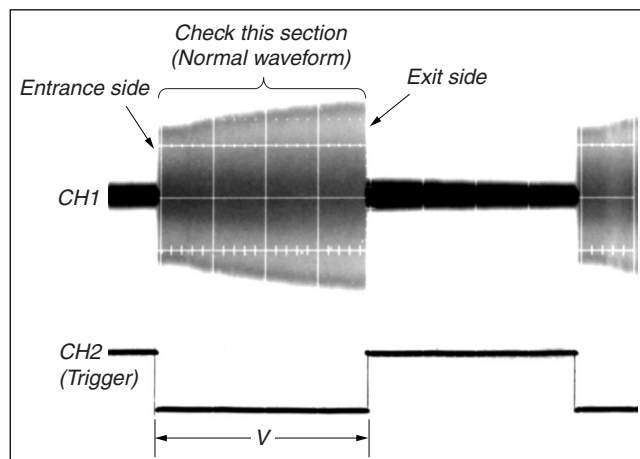

Fig. 5-2-1.

2-1-2. TAPE PATH ADJUSTMENT

1. Preparations for Adjustment

- 1) Clean the tape path face (tape guide, capstan shaft, pinch roller).
- 2) Connect the adjustment remote commander to the LANC jack.
- 3) Turn on the HOLD switch of the adjustment remote commander.
- 4) Select page: 0, address: 01, and set data: 01.
- 5) Select page: 7, address: 62, and set data: 02.
- 6) Select page: C, address: 3E, set data: 08, and press the PAUSE button of the adjustment remote commander.
(Be sure to perform "Processing after operation" after completing adjustments.)
- 7) Connect the oscilloscope to VC-278 board CN1108 via CPC-13 jig (J-6082-443-A).
Channel 1: VC-278 board, CN1108 Pin ⑤
External trigger: VC-278 board, CN1108 Pin ⑧
- 8) Playback Hi8/standard 8mm alignment tape for tracking. (WR5-1NP (NTSC), WR5-1CP (PAL))
- 9) Check that the oscilloscope RF waveform is normal at the entrance and exit. (Fig. 5-2-1.)
If not normal, adjust according to the separate volume "8mm Video Mechanical Adjustment Manual [M2000 Mechanism]".
- 10) Perform "Processing after operations", after completing adjustment.

CN1108 of VC-278 board

Pin No.	Signal Name	Pin No.	Signal Name
1	REG GND	11	VCO
2	N. C.	12	EVF VG
3	BPF MONI	13	RF SWP
4	N. C.	14	N. C.
5	PB RF	15	CAP FG
6	REG GND	16	RF MON
7	N. C.	17	N. C.
8	RF SWP	18	REG GND
9	N. C.	19	REG GND
10	N. C.	20	REG GND

Table 5-2-1.

[Procedure after operations]

- 1) Connect the adjustment remote commander, and turn on the HOLD switch.
- 2) Select page: 0, address: 01, and set data: 01.
- 3) Select page: 7, address: 62, and set data: 00.
- 4) Select page: C, address: 3E, set data: 00, and press the PAUSE button.
- 5) Select page: 0, address: 01, and set data: 00.
- 6) Remove the power supply from the unit.

2-2. DIGITAL8 MODE

Note: Before performing the adjustments, check the data of page: 0, address: 10 is "00". If not, set data: 00 to this address.

2-2-1. HOW TO ENTER RECORD MODE WITHOUT CASSETTE

- 1) Connect the adjustment remote commander to the LANC jack.
- 2) Turn the HOLD switch of the adjustment remote commander to the ON position.
- 3) Close the cassette compartment without the cassette.
- 4) Select page: 3, address: 01, and set data: 0C, and press the PAUSE button of the adjustment remote commander. (The mechanism enters the record mode automatically.)
Note: The function buttons becomes inoperable.
- 5) To quit the record mode, select page: 3, address: 01, set data: 00, and press the PAUSE button. (Whenever you want to quit the record mode, be sure to quit following this procedure.)

2-2-2. HOW TO ENTER PLAYBACK MODE WITHOUT CASSETTE

- 1) Connect the adjustment remote commander to the LANC jack.
- 2) Turn the HOLD switch of the adjustment remote commander to the ON position.
- 3) Close the cassette compartment without the cassette.
- 4) Select page: 3, address: 01, and set data: 0B, and press the PAUSE button. (The mechanism enters the playback mode automatically.)
Note: The function buttons becomes inoperable.
- 5) To quit the playback mode, select page: 3, address: 01, set data: 00, and press the PAUSE button. (Whenever you want to quit the playback mode, be sure to quit following this procedure.)

2-2-3. OVERALL TAPE PATH CHECK

1. Recording of the tape path check signal

- 1) Clean the tape running side (tape guide, capstan shaft, pinch roller).
- 2) Connect the adjustment remote commander to the LANC jack.
- 3) Turn the HOLD switch of the adjustment remote commander to the ON position.
- 4) Set to the camera recording mode.
- 5) Select page: 3, address: 1C, set data: 5D, and press the PAUSE button of the adjustment remote commander.
- 6) Record for several minutes.
- 7) Release the camera recording mode.
- 8) Select page: 3, address: 1C, set data: 00, and press the PAUSE button.

2. Tape path check

- 1) Clean the tape running side (tape guide, capstan shaft, pinch roller).
- 2) Connect the adjustment remote commander to the LANC jack.
- 3) Turn the HOLD switch of the adjustment remote commander to the ON position.
- 4) Connect an oscilloscope to VC-278 board CN1108 via the CPC-13 jig (J-6082-443-A).
Channel 1: VC-278 board, CN1108 Pin ⑯ (Note)
External trigger: VC-278 board, CN1108 Pin ⑬
Note: Connect a 75Ω resistor between Pins ⑯ of CN1108 and ⑥ (GND).
- 5) Select page: 7, address: 62, and set data: 01.
- 6) Playback the tape path check signal.
- 7) Select page: 3, address: 26, and set data: 31.
- 8) Select page: 3, address: 33, and set data: 08.
- 9) Check that the oscilloscope RF waveform is flat at the entrance and exit.
If not flat, perform "2-1-2. TAPE PATH ADJUSTMENT" of "2-1. HI8/STANDARD 8mm MODE".
- 10) Select page: 3, address: 26, and set data: 00.
- 11) Select page: 3, address: 33, and set data: 00.
- 12) Select page: 7, address: 62, and set data: 00.

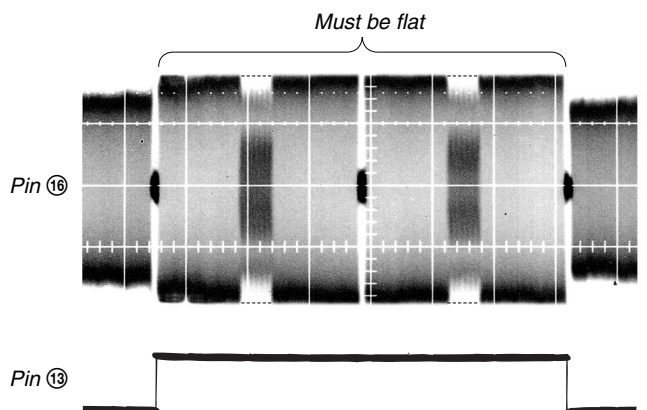

Fig. 5-2-2.

5-3. VIDEO SECTION ADJUSTMENT

3-1. PREPARATIONS BEFORE ADJUSTMENTS

Use the following measuring instruments for video section adjustments.

3-1-1. Equipment to Required

- 1) TV monitor
- 2) Oscilloscope (dual-phenomenon, band width above 30 MHz with delay mode) (Unless specified otherwise, use a 10 : 1 probe.)
- 3) Frequency counter
- 4) Pattern generator with video output terminal
- 5) Digital voltmeter
- 6) Audio generator
- 7) Audio level meter
- 8) Audio distortion meter
- 9) Audio attenuator
- 10) Regulated power supply
- 11) Digital8 alignment tapes
 - SW/OL standard (WR5-2D)
Parts code: 8-967-993-22
 - Audio operation check for NTSC (WR5-3ND)
Parts code: 8-967-993-32
 - System operation check for NTSC (WR5-5ND)
Parts code: 8-967-993-42
 - Audio operation check for PAL (WR5-3CD)
Parts code: 8-967-993-37
 - System operation check for PAL (WR5-5CD)
Parts code: 8-967-993-47
- 12) NTSC Hi8/standard8 alignment tapes (For NTSC model)
 - For tracking adjustment (WR5-1NP)
Parts code : 8-967-995-02
 - For video frequency characteristics adjustment (WR5-7NE)
Parts code : 8-967-995-13
 - For checking Standard 8 mode operations
For LP (WR5-4NL)
Parts code : 8-967-995-51
For SP (WR5-5NSP)
Parts code : 8-967-995-42

Note : The following alignment tapes can also be used.
WR5-4NSP (8-967-995-41)

 - For checking Hi8 mode operations
For LP (WR5-8NLE)
Parts code : 8-967-995-52
For SP (WR5-8NSE)
Parts code : 8-967-995-43
 - For Checking AFM stereo operations (WR5-9NS)
Parts code : 8-967-995-23
 - For BPF adjustment (WR5-11NS)
Parts code : 8-967-995-71
- 13) PAL Hi8/standard8 alignment tapes (For PAL model)
 - For tracking adjustment (WR5-1CP)
Parts code : 8-967-995-07
 - For video frequency characteristics adjustment (WR5-7CE)
Parts code : 8-967-995-18
 - For checking Standard 8 mode operations
For LP (WR5-4CL)
Parts code : 8-967-995-56
For SP (WR5-5CSP)
Parts code : 8-967-995-47

Note : The following alignment tapes can also be used.

 - 1) WR5-3CL (8-967-995-36)
 - 2) WR5-4CSP (8-967-995-46)
 - For checking Hi8 mode operations
For LP (WR5-8CLE)
Parts code : 8-967-995-57
For SP (WR5-8CSE)
Parts code : 8-967-995-48
 - For Checking AFM stereo operations (WR5-9CS)
Parts code : 8-967-995-28
 - For BPF adjustment (WR5-11CS)
Parts code : 8-967-995-76
- 14) Adjustment remote commander (J-6082-053-B)
- 15) CPC-13 jig (J-6082-443-A)

3-1-2. Precautions on Adjusting

Note1: Before performing the adjustments, check the data of page: 0, address: 10 is "00". If not, set data: 00 to this address.

- 1) The adjustments of this unit are performed in the VTR mode or camera mode.

To set to the VTR mode, set the power switch to "VCR or PLAYER" or set the "Forced VTR Power ON mode" using the adjustment remote commander (Note2).

To set to the Camera mode, set the power switch to "CAMERA" or set the "Forced Camera Power ON mode" using the adjustment remote commander (Note3).

After completing adjustments, be sure to exit the "Forced VTR Power ON Mode" or "Forced Camera Power ON Mode". (Note4)

- 2) The front panel block (SI-032 board (Microphone amp., remote commander receiver), FP-411 flexible (MIC jack, Head phone jack, LANC jack, MF photo sensor)) must be assembled for connecting the adjusting remote commander.

To remove it, disconnect the following connector.

VC-278 board CN1116 (30P 0.5mm)

- 3) As removing the cabinet (R) assembly (removing CN1110 of the VC-278 board) means removing the lithium 3V power supply (BT001 on the CF-2500 block), data such as date, time, user-set menus will be lost. After completing adjustments, reset these data.

But the self-diagnosis data and the data on history of use (total drum rotation time etc.) will be kept even if the lithium 3V power supply is removed. (Refer to "5-4.Service Mode" for the self-diagnosis data and the data on history of use.)

- 4) The cabinet (R) assembly (CF-2500 block, LCD block) need not be connected to operate the VTR block. (Use the adjustment remote commander, to operate the VTR block.) When removing the cabinet (R) assembly, disconnect the following connector.

1. VC-278 board CN1110 (22P, 0.5mm)

2. VC-278 board CN1106 (20P, 0.8mm)

- 5) The memory stick connector is need not be connected. To remove it, disconnect the following connector.

VC-278 board CN1105 (10P, 0.5mm)

- 6) The viewfinder block is need not be connected. To remove it, disconnect the following connector.

VC-278 board CN7001 (20P, 0.5mm)

- 7) The lens block (CD-358 board) need not be connected. To remove, disconnect the following connectors.

1. VC-278 board CN1501 (24P, 0.5mm)

2. VC-278 board CN1551 (24P, 0.5mm)

- 8) By setting the "Forced VTR Power ON mode" or "Forced Camera Power ON mode", the video section can be operate even if the cabinet (L) assembly (SS-1380 block) has been removed. When removing the cabinet (L) assembly, disconnect the following connector.

1. VC-278 board CN1109 (12P 0.8mm)

Note2: Setting the "Forced VTR Power ON" mode (VTR mode)

1) Select page: 0, address: 01, and set data: 01.

2) Select page: D, address: 10, set data: 02, and press the PAUSE button.

The above procedure will enable the VTR power to be turned on with the cabinet (L) assembly (SS-1380 block) removed.

After completing adjustments, be sure to exit the "Forced VTR Power ON mode".

Note3: Setting the "Forced Camera Power ON" mode (Camera mode)

1) Select page: 0, address: 01, and set data: 01.

2) Select page: D, address: 10, set data: 01, and press the PAUSE button.

The above procedure will enable the camera power to be turned on with the cabinet (L) assembly (SS-1380 block) removed.

After completing adjustments, be sure to exit the "Forced Camera Power ON mode".

Note4: Exiting the "Forced Power ON" mode

1) Select page: 0, address: 01, and set data: 01.

2) Select page: D, address: 10, set data: 00, and press the PAUSE button.

3) Select page: 0, address: 01, and set data: 00.

3-1-3. Adjusting Connectors

Some of the adjusting points of the video section are concentrated at VC-278 board CN1108. Connect the measuring instruments via the CPC-13 jig (J-6082-443-A). The following table lists the pin numbers and signal names of CN1108.

Pin No.	Signal Name	Pin No.	Signal Name
1	REG GND	11	VCO
2	N. C.	12	EVF VG
3	BPF MONI	13	RF SWP
4	N. C.	14	N. C.
5	PB RF	15	CAP FG
6	REG GND	16	RF MON
7	N. C.	17	N. C.
8	RF SWP	18	REG GND
9	N. C.	19	REG GND
10	N. C.	20	REG GND

Table 5-3-1.

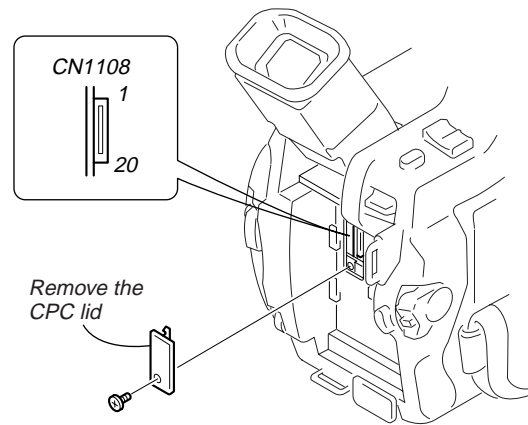

Fig. 5-3-1.

3-1-4. Connecting the Equipment

Connect the measuring instruments as shown in Fig. 5-3-2 and perform the adjustments.

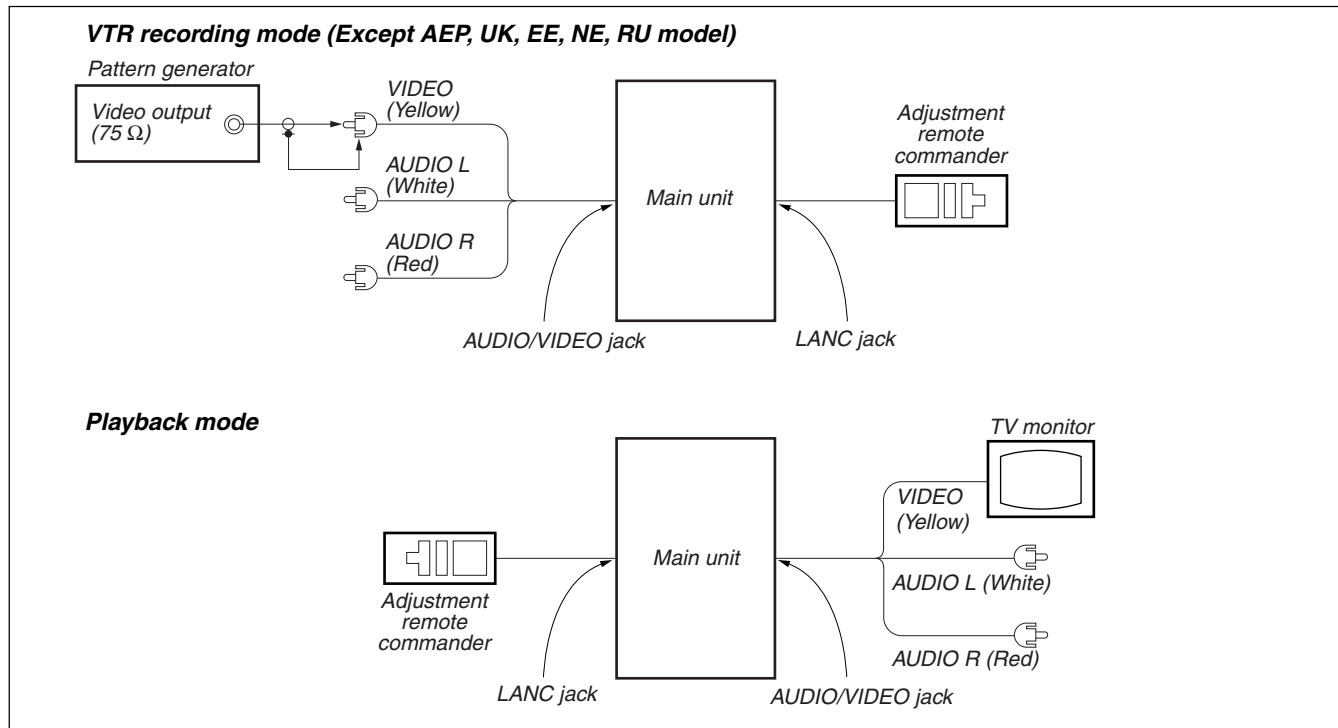

Fig. 5-3-2.

- Abbreviation
 EE : East European model
 NE : North European model
 RU : Russian model

3-1-5. Alignment Tape

The following table lists alignment tapes which are available. Use the tape specified in the signal column for each adjustment. If the type of tape to be used for checking operations is not specified, use whichever type.

Digital8 alignment tape

Name	Usage
SW/OL standard (WR5-2D)	Switching position adjustment
Audio operation check (WR5-3ND (NTSC), WR5-3CD (PAL))	Audio system adjustment
System operation check (WR5-5ND (NTSC), WR5-5CD (PAL))	Operation check

Hi8/standard 8 mm alignment tape

Name	Recording mode	Tape type	Tape speed	Usage
Tracking (WR5-1NP(NTSC), WR5-1CP(PAL))	Standard 8	MP	SP	Tape path adjustment, Switching position adjustment
Video frequency characteristics (WR5-7NE(NTSC), WR5-7CE(PAL))	Hi8	ME	SP(NTSC) LP(PAL)	Frequency characteristics adjustment
Operation check (WR5-5NSP(NTSC), WR5-5CSP(PAL))	Standard 8	MP	SP	Operation check
Operation check (WR5-8NSE(NTSC), WR5-8CSE(PAL))	Hi8	ME	SP	
Operation check (WR5-4NL(NTSC), WR5-4CL(PAL))	Standard 8	MP	LP	
Operation check (WR5-8NLE(NTSC), WR5-8CLE(PAL))	Hi8	ME	LP	
AFM stereo operation check WR5-9NS(NTSC), WR5-9CS(PAL)	Standard 8	MP	SP	AFM stereo Operation check
BPF adjustment WR5-11NS(NTSC), WR5-11CS(PAL)	Standard 8	MP	SP	BPF adjustment

Tape type

ME Particle type metal tape

MP Evaporated type metal tape

Table. 5-3-2.

Fig. 5-3-3. Shows the color bar signals recorded on the alignment tape.

Note: Measure using the video terminal of AUDIO/VIDEO jack (Terminated at 75 Ω).

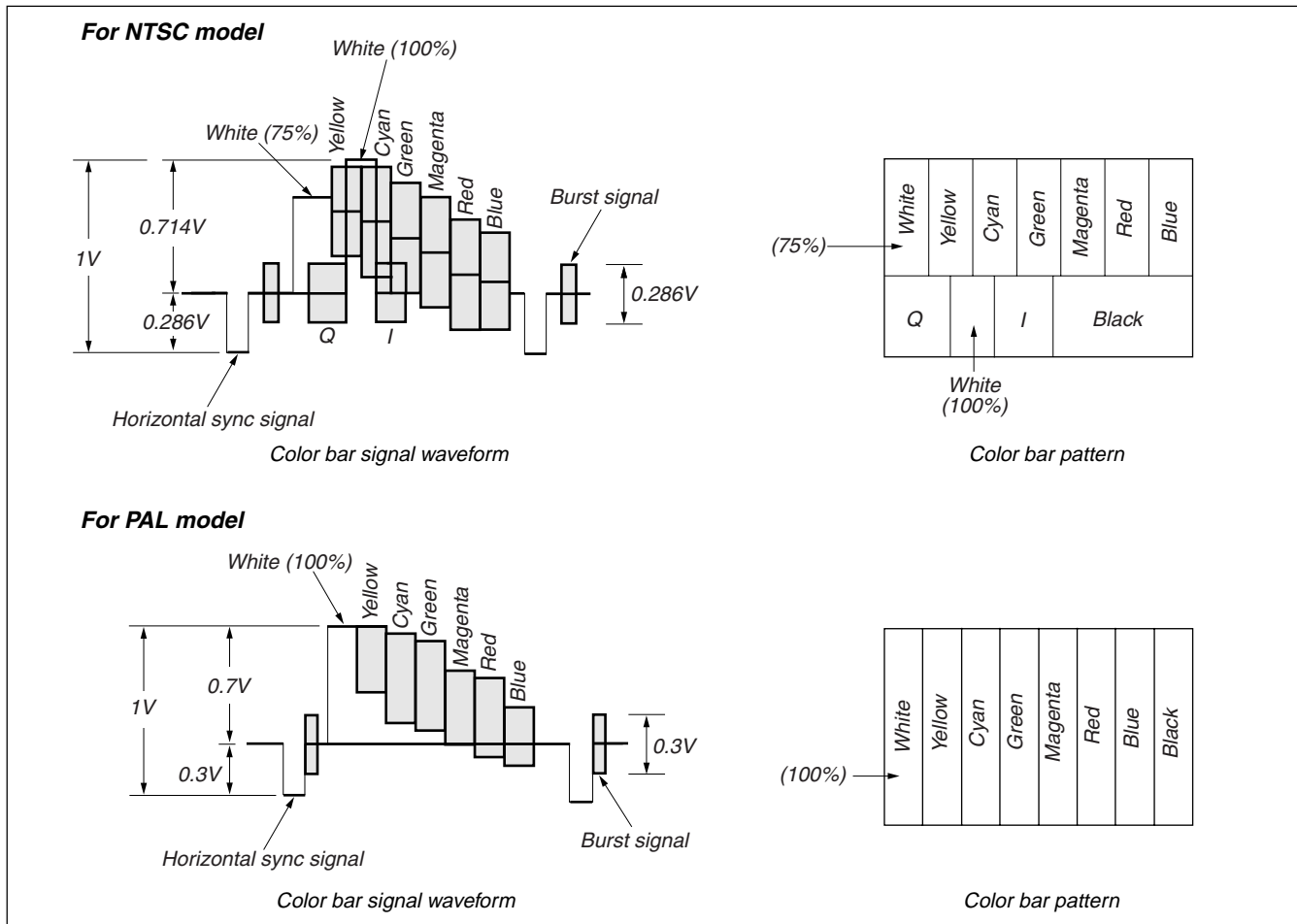

Fig. 5-3-3. Color Bar Signal of the Alignment Tape

3-1-6. Input/output Level and Impedance

Video input/output

Special stereo minijack, 1Vp-p, 75Ω, unbalanced, sync negative

S video input/output

4-pin mini DIN

Luminance signal:

1Vp-p, 75Ω, unbalanced, sync negative

Chrominance signal:

0.286Vp-p, 75Ω, unbalanced (NTSC)

0.300Vp-p, 75Ω, unbalanced (PAL)

Audio input/output

Special stereo minijack:

Input: -7.5dBs, input impedance more than 47kΩ

Output: -7.5dBs, (at load impedance 47kΩ), output impedance less than 2.2kΩ

3-2. SYSTEM CONTROL SYSTEM ADJUSTMENT

1. Initialization of 8, A, B, C, D, E, F, 1B, 1C, 1E, 1F Page Data

If the 8, A, B, C, D, E, F, 1B, 1C, 1E, 1F page data is erased due to some reason, perform "1-2. INITIALIZATION OF PAGE DATA" of "5-1. CAMERA SECTION ADJUSTMENT"

Note: When reading or writing the 1B, 1C, 1E, 1F page data, select page: 0, address: 10, and set data: 01, then select B, C, E or F page. The 1B, 1C, 1E or 1F page can be chosen by this data setting. After reading or writing, reset the data of page: 0, address: 10 to "00".

2. Serial No. Input

Note: Before performing the adjustments, check the data of page: 0, address: 10 is "00". If not, set data: 00 to this address.

2-1. Company ID Input

Write the company ID in the EEPROM (nonvolatile memory).

Page	8
Address	8C, 8D, 8E, 8F, 90

Input method:

- 1) Select page: 0, address: 01, and set data: 01.
- 2) Input the following data to page: 8, addresses: 8C to 90.
Note: Press the PAUSE button of the adjustment remote commander each time to set the data.
- 3) Select page: 0, address: 01, and set data: 00.

Address	Data
8C	08
8D	00
8E	46
8F	01
90	02

2-2. Serial No. Input

Write the serial No. and model code in the EEPROM (nonvolatile memory). Convert the serial No. on the name plate from decimal to hexadecimal, and write in the EEPROM.

Page	8
Address	91, 92, 93

Input method:

- 1) Select page: 0, address: 01, and set data: 01.
- 2) Read the serial No. on the name plate, and take it as D₁.

Example: If the serial No. is 77881.

$$D_1 = 77881$$

Note: Use six digits of the low rank when a serial No. is more than seven digits.

- 3) Obtain D₂ and H₁ corresponding to D₁ from Table 5-3-3.

Example: If D₁ is "77881".

$$D_2 = D_1 - 65536 = 12345$$

$$H_1 = FE$$

D ₁ (Decimal)	D ₂ (Decimal)	H ₁ (Hexadecimal) (Service model code)
000001 to 065535	D ₁	FE
065536 to 131071	D ₁ - 65536	FE
131072 to 196607	D ₁ - 131072	FE

Table 5-3-3.

- 4) Input H₁ to page: 8, address: 91. (Model code input)
Example: If H₁ is "FE".
Select page: 8, address: 91, set data: FE, and press the PAUSE button.
- 5) Obtain the maximum decimal not exceeding D₂ from Table 5-3-4, and take this as D₃.
Example: If D₂ is "12345".
 $D_3 = 12288$
- 6) Obtain the hexadecimal corresponding to D₃ from Table 5-3-4, and take this as H₃.
Example: If D₃ is "12288".
 $H_3 = 3000$
- 7) Obtain the difference D₄ between D₂ and D₃. (Decimal calculation, $0 \leq D_4 \leq 255$)
 $D_4 = D_2 - D_3$
Example: If D₂ is "12345" and D₃ is "12288".
 $D_4 = 12345 - 12288 = 57$
- 8) Convert D₄ to hexadecimal, and take this as H₄. (Refer to "Hexadecimal-decimal conversion table" in "5-4. Service Mode".)
Example: If D₄ is "57".
 $H_4 = 39$
- 9) Input the upper 2 digits of H₃ to page: 8, address: 92.
Example: If H₃ is "3000".
Select page: 8, address: 92, set data: 30, and press the PAUSE button.
- 10) Input H₄ to page: 8, address: 93.
Example: If H₄ is "39".
Select page: 8, address: 93, set data: 39, and press the PAUSE button.
- 11) Select page: 0, address: 01, and set data: 00.

DCR-TRV738E/TRV740/TRV740E/TRV840

Decimal (D ₃)	Hexa-decimal (H ₃)	Decimal (D ₃)	Hexa-decimal (H ₃)	Decimal (D ₃)	Hexa-decimal (H ₃)	Decimal (D ₃)	Hexa-decimal (H ₃)	Decimal (D ₃)	Hexa-decimal (H ₃)	Decimal (D ₃)	Hexa-decimal (H ₃)	Decimal (D ₃)	Hexa-decimal (H ₃)	Decimal (D ₃)	Hexa-decimal (H ₃)
0	0000	8192	2000	16384	4000	24576	6000	32768	8000	40960	A000	49152	C000	57344	E000
256	0100	8448	2100	16640	4100	24832	6100	33024	8100	41216	A100	49408	C100	57600	E100
512	0200	8704	2200	16896	4200	25088	6200	33280	8200	41472	A200	49664	C200	57856	E200
768	0300	8960	2300	17152	4300	25344	6300	33536	8300	41728	A300	49920	C300	58112	E300
1024	0400	9216	2400	17408	4400	25600	6400	33792	8400	41984	A400	50176	C400	58368	E400
1280	0500	9472	2500	17664	4500	25856	6500	34048	8500	42240	A500	50432	C500	58624	E500
1536	0600	9728	2600	17920	4600	26112	6600	34304	8600	42496	A600	50688	C600	58880	E600
1792	0700	9984	2700	18176	4700	26368	6700	34560	8700	42752	A700	50944	C700	59136	E700
2048	0800	10240	2800	18432	4800	26624	6800	34816	8800	43008	A800	51200	C800	59392	E800
2304	0900	10496	2900	18688	4900	26880	6900	35072	8900	43264	A900	51456	C900	59648	E900
2560	0A00	10752	2A00	18944	4A00	27136	6A00	35328	8A00	43520	AA00	51712	CA00	59904	EA00
2816	0B00	11008	2B00	19200	4B00	27392	6B00	35584	8B00	43776	AB00	51968	CB00	60160	EB00
3072	0C00	11264	2C00	19456	4C00	27648	6C00	35840	8C00	44032	AC00	52224	CC00	60416	EC00
3328	0D00	11520	2D00	19712	4D00	27904	6D00	36096	8D00	44288	AD00	52480	CD00	60672	ED00
3584	0E00	11776	2E00	19968	4E00	28160	6E00	36352	8E00	44544	AE00	52736	CE00	60928	EE00
3840	0F00	12032	2F00	20224	4F00	28416	6F00	36608	8F00	44800	AF00	52992	CF00	61184	EF00
4096	1000	12288	3000	20480	5000	28672	7000	36864	9000	45056	B000	53248	D000	61440	F000
4352	1100	12544	3100	20736	5100	28928	7100	37120	9100	45312	B100	53504	D100	61696	F100
4608	1200	12800	3200	20992	5200	29184	7200	37376	9200	45568	B200	53760	D200	61952	F200
4864	1300	13056	3300	21248	5300	29440	7300	37632	9300	45824	B300	54016	D300	62208	F300
5120	1400	13312	3400	21504	5400	29696	7400	37888	9400	46080	B400	54272	D400	62464	F400
5376	1500	13568	3500	21760	5500	29952	7500	38144	9500	46336	B500	54528	D500	62720	F500
5632	1600	13824	3600	22016	5600	30208	7600	38400	9600	46592	B600	54784	D600	62976	F600
5888	1700	14080	3700	22272	5700	30464	7700	38656	9700	46848	B700	55040	D700	63232	F700
6144	1800	14336	3800	22528	5800	30720	7800	38912	9800	47104	B800	55296	D800	63488	F800
6400	1900	14592	3900	22784	5900	30976	7900	39168	9900	47360	B900	55552	D900	63744	F900
6656	1A00	14848	3A00	23040	5A00	31232	7A00	39424	9A00	47616	BA00	55808	DA00	64000	FA00
6912	1B00	15104	3B00	23296	5B00	31488	7B00	39680	9B00	47872	BB00	56064	DB00	64256	FB00
7168	1C00	15360	3C00	23552	5C00	31744	7C00	39936	9C00	48128	BC00	56320	DC00	64512	FC00
7424	1D00	15616	3D00	23808	5D00	32000	7D00	40192	9D00	48384	BD00	56576	DD00	64768	FD00
7680	1E00	15872	3E00	24064	5E00	32256	7E00	40448	9E00	48640	BE00	56832	DE00	65024	FE00
7936	1F00	16128	3F00	24320	5F00	32512	7F00	40704	9F00	48896	BF00	57088	DF00	65280	FF00

Table 5-3-4.

3-3. SERVO AND RF SYSTEM ADJUSTMENT

Before perform the servo and RF system adjustments, check that the specified value of “54MHz/66MHz Origin Oscillation Adjustment” of “VIDEO SYSTEM ADJUSTMENT” is satisfied. And check that the data of page: 0, address: 10 is “00”. If not, set data: 00 to this address.

Note: NTSC model: DCR-TRV740/TRV840
PAL model: DCR-TRV738E/TRV740E

Adjusting Procedure:

1. REEL FG adjustment
2. PLL f₀ & LPF f₀ adjustment
3. Switching position adjustment
4. AGC center level and APC & AEQ adjustment
5. PLL f₀ & LPF f₀ fine adjustment
6. Hi8/Standrd8 switching position adjustment
7. Cap FG duty adjustment

1. REEL FG Adjustment (VC-278 board)

Compensates the dispersion of the hall elements.

Measurement Point	Display data of page: 3, address: 03
Measuring Instrument	Adjustment remote commander
Adjustment Page	C
Adjustment Address	17, 2F
Specified Value	00 or 01 or 04 or 05

Note: The data of page: 0, address: 10 must be “00”.

Adjusting method:

Order	Page	Address	Data	Procedure
1				Close the cassette compartment without inserting a cassette.
2	0	01	01	Set the data.
3	3	01	1C	Set the data, and press PAUSE button.
4	3	02		Check that the data changes to “00”.
5	3	03		Check that the data is “00” or “01” or “04” or “05”. (Note)
6	0	01	00	Set the data.

Note: If the data is other value, adjustment has errors. (Take an appropriate remedial measures according to the errors referring to the following table.)

Data	Contents of defect
02, 03, 06, 07	T reel is defective
08, 09, 0C, 0D	S reel is defective
0A, 0B, 0E, 0F	S reel and T reel are defective

2. PLL f₀ & LPF f₀ Adjustment (VC-278 board)

Mode	VTR stop
Measurement Point	Display data of page: 3, address: 02, 03
Measuring Instrument	Adjustment remote commander
Adjustment Page	C
Adjustment Address	1F, 20, 22, 29
Specified Value	Data of page: 3, address: 02 is “00”. Data of page: 3, address: 03 is “00”.

Note1: The data of page: 0, address: 10 must be “00”.

Adjusting method:

Order	Page	Address	Data	Procedure
1	0	01	01	Set the data.
2	C	21	CA	Set the data, and press PAUSE button.
3	3	01	00	Set the data, and press PAUSE button.
4	3	01	30	Set the data, and press PAUSE button.
5	3	02		Check that the data changes to “00” with in 10 sec. (Note2)
6	3	03		Check that the data is “00”. (Note2)
7	0	01	00	Set the data.

Note2: If it isn't satisfied, select page: C, address: 21, set the following data, and press the PAUSE button, and repeat steps 3 to 6.

	Setting data
When the data of page: C, address: 21 is “CA”.	CE
When the data of page: C, address: 21 is “CE”.	C6
When the data of page: C, address: 21 is “C6”.	D2
When the data of page: C, address: 21 is “D2”.	C2

There are errors when it isn't satisfied even if the above treatment is done.

If bit2, bit3, bit4, bit5 or bit 6 of the data of page: 3, address: 03 is “1”, there are errors. For the error contents, see the following table. (For the bit values, refer to “5-4. SERVICE MODE”, “4-3. 3. Bit value discrimination”).

Bit value of page: 3, address: 03 data	Error contents
bit 2 = 1 or bit 3 = 1	PLL f ₀ fine adjustment is defective
bit 4 = 1 or bit 5 = 1	PLL f ₀ adjustment is defective
bit 6 = 1	LPF f ₀ adjustment is defective

3. Switching Position Adjustment (VC-278 board) *RadarW*

To obtain normal playback waveform output during the Digital8 playback mode, adjust the switching position.

Mode	VTR playback
Signal	SW/OL reference tape (WR5-2D)
Measurement Point	Display data of page: 3, address: 03
Measuring Instrument	Adjustment remote commander
Adjustment Page	C
Adjustment Address	10, 11, 12, 13
Specified Value	00

Note1: The data of page: 0, address: 10 must be "00".

Adjusting method:

Order	Page	Address	Data	Procedure
1				Insert the SW/OL reference tape and enter the VTR STOP mode.
2	0	01	01	Set the data.
3	C	10	EE	Set the data, and press PAUSE button.
4	3	21		Check that the data is "02". (Note2)
5	3	01	0D	Set the data, and press PAUSE button.
6	3	02		Check that the data changes to "00" in the following order. "0E"→"29"→"0E"→"20"→"00"
7	3	03		Check that the data is "00". (Note3)
8	C	10		Check that the data is other than "EE". (Note3)
9	0	01	00	Set the data.

Note2: If the data of page: 3, address: 21 is "72", the tape top being played. After playing the tape for 1 to 2 seconds, stop it, perform step 5 and higher.

Note3: If the data is other than "00", select page: C, address: 21, after write down the data, set data: 10, and press the PAUSE button, and repeat from step1.

There are errors when the data of page: 3, address: 03 is other than "00" even if this treatment is done. Select page: C, address: 21, set the data written down, and press the PAUSE button.

If bit 0 of the data is "1", the A channel is defective. If bit 1 is "1", the B channel is defective. Contents of the defect is written into page: C, addresses: 10 and 12. See the following table. (For the bit values, refer to "5-4. SERVICE MODE", "4-3. 3. Bit value discrimination".) If bit 3 of the data is "1", the tape end being played, and adjustment has errors.

Note4: If the data is "EE", rewind the tape and repeat steps 1 to 7.

When the A channel is defective

Data of page: C, address: 10	Contents of defect
EE	Writing into EEPROM (IC4502) is defective
E8	Adjustment data is out of range
E7	No data is returned from IC3301

When the B channel is defective

Data of page: C, address: 12	Contents of defect
E8	Adjustment data is out of range
E7	No data is returned from IC3301

4. AGC Center Level and APC & AEQ Adjustment

Note: The data of page: 0, address: 10 must be "00".

Use a Hi8 MP tape.

4-1. Preparations before adjustments

Mode	Camera recording
Subject	Arbitrary

Adjusting method:

Order	Page	Address	Data	Procedure
1	0	01	01	Set the data.
2	8	21	C8	Set the data.
3				Record the camera signal for three minutes.

4-2. AGC Center Level Adjustment (VC-278 board)*RadarW*

Mode	Playback
Signal	Recorded signal at "Preparations before adjustments"
Measurement Point	Pin ⑩ of CN1108 (RF MON) (Note 1) Ext. trigger: Pin ⑬ of CN1108 (RF SWP)
Measuring Instrument	Oscilloscope
Adjustment Page	C
Adjustment Address	1E
Specified Value	The data of page: 3, address: 03 is "00"

Note1: Connect a 75Ω resistor between Pin ⑩ and Pin ⑳ (GND) of CN1108.

75Ω resistor (Parts code: 1-247-804-11)

Adjusting method:

Order	Page	Address	Data	Procedure
1				Playback the recorded signal at "Preparations before adjustments"
2	0	01	01	Set the data.
3	7	62	01	Set the data.
4	3	33	08	Set the data.
5				Confirm that the playback RF signal is stable. (Fig. 5-3-4.)
6	3	01	23	Set the data, and press PAUSE button.
7	3	02		Check that the data is "00".
8	3	03		Check that the data is "00". (Note2)
9				Perform "APC & AEQ Adjustment".

Note2: If the data of page: 3, address: 03 is other than "00", adjustment has errors.

4-3. APC & AEQ Adjustment (VC-278 board) 

Mode	Playback
Signal	Recorded signal at "Preparations before adjustments"
Measurement Point	Pin ⑯ of CN1108 (RF MON) (Note 1) Ext. trigger: Pin ⑬ of CN1108 (RF SWP)
Measuring Instrument	Oscilloscope
Adjustment Page	C
Adjustment Address	18, 19, 1B, 1C, 21, 2C
Specified Value	The data of page: 3, address: 03 is "00"

Note1: Connect a 75Ω resistor between Pin ⑯ and Pin ⑳ (GND) of CN1108.

75Ω resistor (Parts code: 1-247-804-11)

Note2: The "AGC Center Level Adjustment" must have already been completed before starting this adjustment.

Adjusting method:

Order	Page	Address	Data	Procedure
1	0	01	01	Set the data.
2	C	18	20	Set the data, and press PAUSE button.
3	C	19	20	Set the data, and press PAUSE button.
4	C	1B	25	Set the data, and press PAUSE button.
5	C	1C	25	Set the data, and press PAUSE button.
6	C	21	CA	Set the data, and press PAUSE button.
7	C	2C	03	Set the data, and press PAUSE button.
8				Playback the recorded signal at "Preparations before adjustments"
9	7	62	01	Set the data.
10	3	33	08	Set the data.
11				Confirm that the playback RF signal is stable. (Fig. 5-3-4.)
12	3	01	07	Set the data, and press PAUSE button.
13	3	02		Check that the data changes from "07" to "00" in about 20 seconds after pressing PAUSE button.
14	3	03		Check that the data is "00". (Note3)
15				Perform "Processing after Completing Adjustments".

Note3: If the data is other than "00", adjustment has errors.

4-4. Processing after Completing Adjustments 

Order	Page	Address	Data	Procedure
1	0	01	01	Set the data.
2	7	62	00	Set the data.
3	3	33	00	Set the data.
4	8	21	00	Set the data, and press PAUSE button.
5	0	01	00	Set the data.

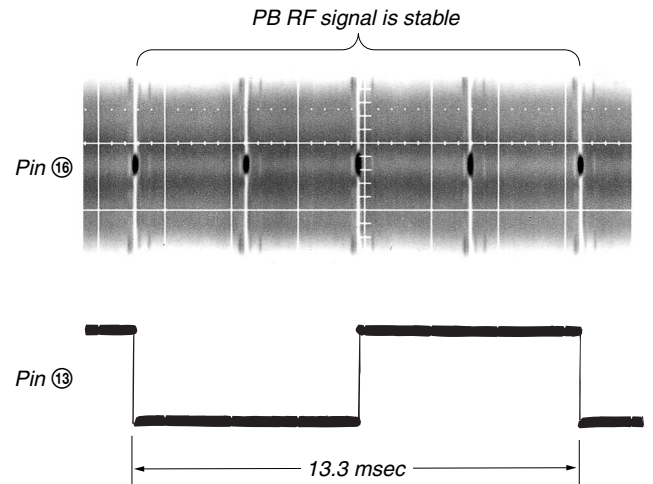

Fig. 5-3-4.

5. PLL f₀ & LPF f₀ Fine Adjustment (VC-278 board)

RadarW

Mode	VTR stop
Signal	Arbitrary
Measurement Point	Display data of page: 3, address: 02, 03
Measuring Instrument	Adjustment remote commander
Adjustment Page	C
Adjustment Address	1F, 20, 22, 29
Specified Value	Display data of page: 3, address: 02 is "00". Display data of page: 3, address: 03 is "00".

Note1: The data of page: 0, address: 10 must be "00".

Adjusting method:

Order	Page	Address	Data	Procedure
1	0	01	01	Set the data.
2	3	01	30	Set the data, and press PAUSE button.
3	3	02		Check that the data changes to "00" with in 10 sec. (Note2)
4	3	03		Check that the data is "00". (Note3)
5	0	01	00	Set the data.

Note2: If it isn't satisfied, there are errors.

Note3: If the data of page: 3, address: 03 is other than "00", there are errors. For the error contents, see the following table. (For the bit values, refer to "5-4. SERVICE MODE", "4-3. 3. Bit value discrimination".)

Bit value of page: 3, address: 03	Error contents
bit 2 = 1 or bit 3 = 1	PLL f ₀ fine adjustment is defective
bit 4 = 1 or bit 5 = 1	PLL f ₀ adjustment is defective
bit 6 = 1	LPF f ₀ adjustment is defective

6. Hi8/Standard8 Switching Position Adjustment (VC-278 board)

If deviated in this case causes switching noise or jitter on the Hi8/Standard8 mode played back screen.

Mode	Playback
Signal	Hi8/Standard8 alignment tape: For tracking adjustment (WR5-1NP (NTSC), WR5-1CP (PAL))
Measurement Point	CH1: Pin ⑧ of CN1108 (RF SWP) CH2: Pin ⑤ of CN1108 (PB RF)
Measuring Instrument	Oscilloscope
Adjustment Page	C
Adjustment Address	40, 41
Specified Value	t ₁ = 0 ± 10 μsec

Note1: The data of page: 0, address: 10 must be "00".

Adjusting Method:

Order	Page	Address	Data	Procedure
1				Set to the stop mode.
2	0	01	01	Set the data.
3	C	3E	40	Set the data, and press PAUSE button.
4	7	62	02	Set the data.
5				Set to the playback mode.
6	C	40		Change the data and minimize "t ₁ ". (Coarse adjustment)
7	C	40		Press PAUSE button
8	C	41		Change the data and adjust so that the switching position (t ₁) becomes the specified value. (Fine adjustment)
9	C	41		Press PAUSE button
10	C	3E	00	Set the data, and press PAUSE button.
11	7	62	00	Set the data.
12	0	01	00	Set the data.

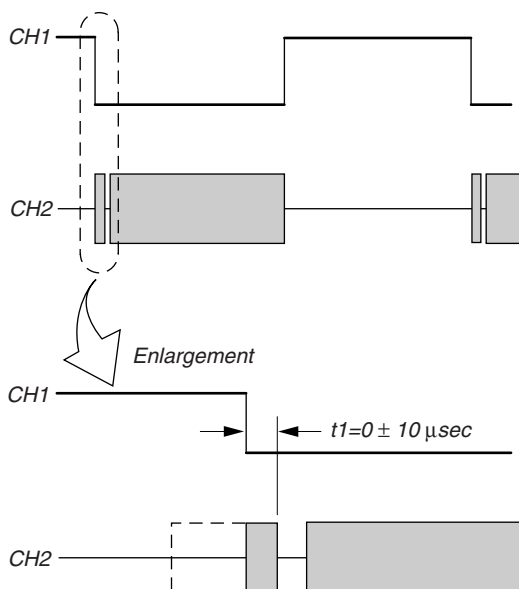

Fig. 5-3-5.

7. CAP FG Duty Adjustment (VC-278 board) **RadarW**

Set the Cap FG signal duty cycle to 50% to establish an appropriate capstan servo. If deviated, the uneven rotation of capstan and noise can occur in the Hi8/Standard8 LP mode.

Mode	Playback
Signal	Hi8/standard 8 alignment tape : For checking operation (WR5-5NSP (NTSC), WR5-5CSP (PAL))
Measurement Point	Pin ⑨ of CN1108 (CAP FG)
Measuring Instrument	Oscilloscope
Adjustment Page	C
Adjustment Address	16
Specified value	Duty = 50 ± 1 %

Note1: The data of page: 0, address: 10 must be "00".

Adjusting method:

Order	Page	Address	Data	Procedure
1				Set to the playback mode.
2	0	01	01	Set the data.
3	3	01	00	Set the data, and press PAUSE button.
4	3	01	81	Set the data, and press PAUSE button.
5	3	02		Check that the data changes from "81" to "00".
6	3	03		Check that the data is "00". (Note2)
7				Check that Duty of CAP FG signal satisfies the specified value. If not, repeat steps 3 to 7.
8	0	01	00	Set the data.

Note2: If the data of page: 3, address: 03 is other than "00", there are errors. For the error contents, see the following table. (For the bit values, refer to "5-4. SERVICE MODE", "4-3. 3. Bit value discrimination".)

Bit value of page: 3, address: 03	Error contents
bit 0 = 1	Adjustment time-out
bit 1 = 1	Hi8/Standard8 mode wasn't set up.

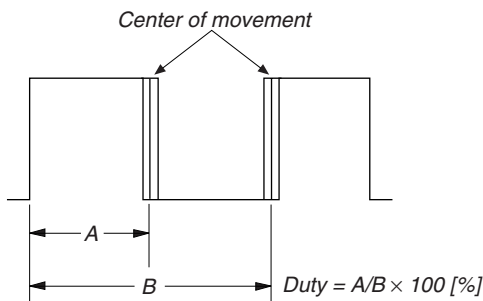

Fig. 5-3-6.

3-4. VIDEO SYSTEM ADJUSTMENTS

Note1: Before performing the adjustments, check the data of page: 0, address: 10 is "00". If not, set data: 00 to this address.

Note2: NTSC model: DCR-TRV740/TRV840
PAL model: DCR-TRV738E/TRV740E

1. 54MHz/66MHz Origin Oscillation Adjustment (VC-278 board)

Set the frequency of the clock for synchronization. If deviated, the synchronization will be disrupted and the color will become inconsistent.

Mode	Camera
Subject	Not required
Measurement Point	Pin ⑩ of IC1502
Measuring Instrument	Frequency counter
Adjustment Page	F
Adjustment Address	10
Specified Value	f = 33000000 ± 166Hz (NTSC) f = 27000000 ± 134Hz (APL)

Note: The data of page: 0, address: 10 must be "00".

Adjusting method:

Order	Page	Address	Data	Procedure
1	0	01	01	Set the data.
2	F	10		Change the data and set the frequency (f) to the specified value.
3	F	10		Press PAUSE button.
4	0	01	00	Set the data.

VC-278 board

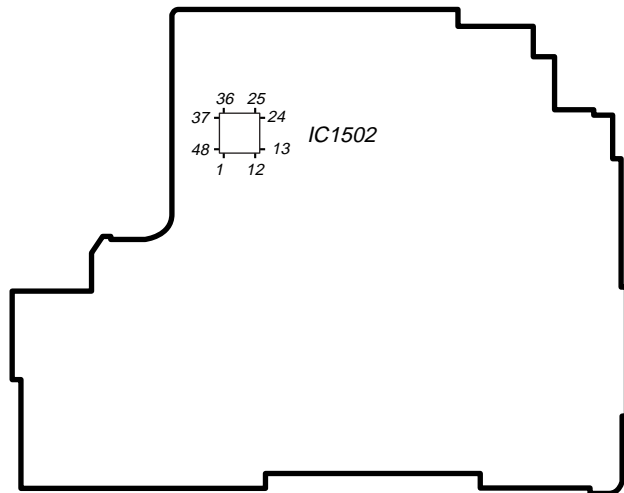

2. S VIDEO OUT Y Level Adjustment (VC-278 board)

Mode	VTR stop
Signal	No signal
Measurement Point	Y signal terminal of S VIDEO jack (75Ω terminated)
Measuring Instrument	Oscilloscope
Adjustment Page	C
Adjustment Address	25
Specified Value	A = 1000 ± 20mV

Note1: The data of page: 0, address: 10 must be "00".

Adjusting method:

Order	Page	Address	Data	Procedure
1	0	01	01	Set the data.
2	A	12	10	Set the data, and press PAUSE button.
3	3	0C	02	Set the data, and press PAUSE button.
4	C	25		Change the data and set the Y signal level (A) to the specified value.
5	C	25		Press PAUSE button.
6	3	0C	00	Set the data, and press PAUSE button.
7	A	12	00	Set the data, and press PAUSE button.
8	0	01	00	Set the data.

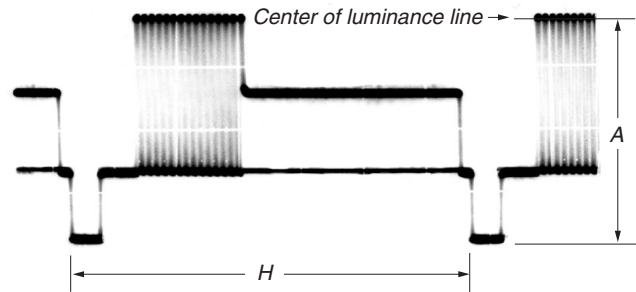

Fig. 5-3-7.

3. S VIDEO OUT Chroma Level Adjustment (VC-278 board)

Mode	VTR stop
Signal	No signal
Measurement Point	Chroma signal terminal of S VIDEO jack (75Ω terminated) External trigger: Y signal terminal of S VIDEO jack
Measuring Instrument	Oscilloscope
Adjustment Page	C
Adjustment Address	26, 27
Specified Value	Cr level: A = 714 ± 14mV (NTSC) A = 700 ± 14mV (PAL) Cb level: B = 714 ± 14mV (NTSC) B = 700 ± 14mV (PAL) Burst level: C = 286 ± 6mV (NTSC) C = 300 ± 6mV (PAL)

Note: The data of page: 0, address: 10 must be "00".

Adjusting method:

Order	Page	Address	Data	Procedure
1	0	01	01	Set the data.
2	A	12	10	Set the data, and press PAUSE button.
3	3	0C	02	Set the data, and press PAUSE button.
4	C	26		Change the data and set the Cr signal level (A) to the specified value.
5	C	26		Press PAUSE button.
6	C	27		Change the data and set the Cb signal level (B) to the specified value.
7	C	27		Press PAUSE button.
8	3	0C	00	Set the data, and press PAUSE button.
9	A	12	00	Set the data, and press PAUSE button.
10	0	01	00	Set the data.

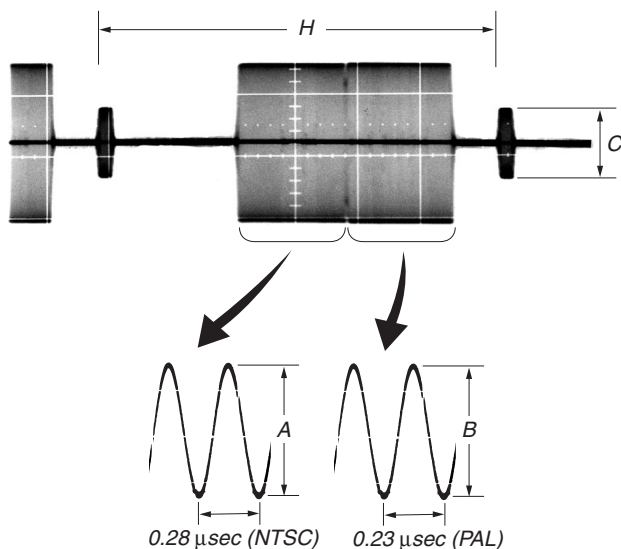

Fig. 5-3-8.

4. VIDEO OUT Y, Chroma Level Check (VC-278 board)

Mode	VTR stop
Signal	No signal
Measurement Point	Video signal terminal of AUDIO/VIDEO jack (75Ω terminated)
Measuring Instrument	Oscilloscope
Specified Value	Sync level: A = 293 ± 18mV (NTSC) A = 307 ± 18mV (PAL) Burst level: B = 286 ± 18mV (NTSC) B = 300 ± 18mV (PAL)

Note: The data of page: 0, address: 10 must be "00".

Adjusting method:

Order	Page	Address	Data	Procedure
1	0	01	01	Set the data.
2	A	12	10	Set the data, and press PAUSE button.
3	3	0C	02	Set the data, and press PAUSE button.
4				Check that the sync signal level (A) satisfies the specified value.
5				Check that the burst signal level (B) satisfies the specified value.
6	3	0C	00	Set the data, and press PAUSE button.
7	A	12	00	Set the data, and press PAUSE button.
8	0	01	00	Set the data.

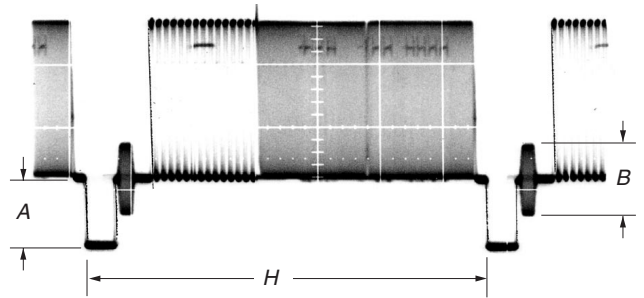

Fig. 5-3-9.

5. Hi8/Standard8 Y/C Output Level Setting (VC-278 board)

Set the Y/C signal output level during the Hi8/Standard8 playback mode.

Mode	VTR stop
Signal	No signal
Adjustment Page	C
Adjustment Address	44, 45

Note1: Perform this adjustment when IC2201 is replaced.

Note2: The data of page: 0, address: 10 must be "00".

Adjusting method:

Order	Page	Address	Data	Procedure
1	0	01	01	Set the data.
2	D	10	02	Set the data, and press PAUSE button.
3	3	9E	01	Set the data.
4	3	A4		Check that the data. When the data is "53", proceed to step 5. When the data is "03", proceed to step 8.
5	C	44	<69> [65]	Set the data, and press PAUSE [65]button. (Note3)
6	C	45	<64> [72]	Set the data, and press PAUSE button. (Note3)
7				Proceed to step 10.
8	C	44	A0	Set the data, and press PAUSE button.
9	C	45	<AA> [B8]	Set the data, and press PAUSE button. (Note3)
10	3	9E	00	Set the data.
11	D	10	00	Set the data, and press PAUSE button.
12	0	01	00	Set the data.

Note3: <>: NTSC model, []: PAL model

6. Hi8/standard 8mm AFC fo Adjustment (VC-278 board)

Adjust the pull-in range of the clock generator (IC2201) for A/D conversion during Hi8/standard 8mm playback.

Mode	VTR stop
Signal	No signal
Measurement Point	Display data of page: 3, address: 9D
Measuring Instrument	Adjustment remote commander
Adjustment Page	C
Adjustment Address	43
Specified Value	7C to 84

Note: The data of page: 0, address: 10 must be "00".

Adjusting method:

Order	Page	Address	Data	Procedure
1	0	01	01	Set the data.
2	D	10	02	Set the data, and press PAUSE button.
3	3	0D	04	Set the data, and press PAUSE button.
4	3	93	04	Set the data.
5	3	9E	01	Set the data.
6	C	43	50	Set the data, and press PAUSE button.
7	3	01	60	Set the data, and press PAUSE button.
8	3	02		Check that the data changes from "60" to "00".
9	3	03		Check that the data is "00".
10	3	01	00	Set the data, and press PAUSE button.
11	3	9D		Check that the data satisfies the specifies value. When the data doesn't satisfy the specified value, return to step 6.
12	3	0D	00	Set the data, and press PAUSE button.
13	3	93	00	Set the data.
14	3	9E	00	Set the data.
15	D	10	00	Set the data, and press PAUSE button.
16	0	01	00	Set the data.

3-5. AUDIO SYSTEM ADJUSTMENTS

Note1: Before performing the adjustments, check the data of page: 0, address: 10 is "00". If not, set data: 00 to this address.

Note2: NTSC model: DCR-TRV740/TRV840
PAL model: DCR-TRV738E/TRV740E

[Connecting the measuring instruments for the audio]

Connect the audio system measuring instruments in addition to the video system measuring instruments as shown in Fig. 5-3-10.

[Adjustment Procedure]

- 1) Hi8/Standard8 AFM BPF f_0 adjustment
- 2) Hi8/Standard8 AFM 1.5MHz deviation adjustment
- 3) Hi8/Standard8 AFM 1.7MHz deviation adjustment
- 4) Digital8 playback level check
- 5) Overall level characteristics check
- 6) Overall distortion check
- 7) Overall noise level check
- 8) Overall separation check

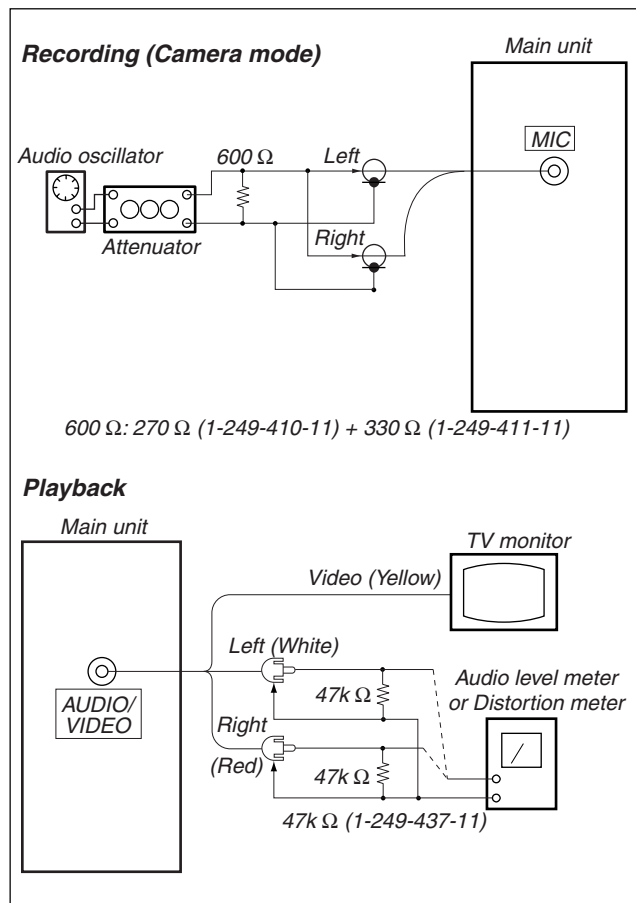

Fig. 5-3-10.

1. Hi8/Standard8 AFM BPF f_0 Adjustment (VC-278 board)

Sets the BPF passing frequency of IC5701 so that the AFM signal can separate from the playback RF signal properly. If deviated, the mono/stereo mode will be differentiated incorrectly, and noises and distortions will increase during high volume playback.

Mode	Playback
Signal	Hi8/Standard8 alignment tape: For BPF adjustment (WR5-11NS (NTSC), WR5-11CS (PAL))
Measurement Point	AUDIO/VIDEO jack left or right
Measuring Instrument	Distortion meter
Adjustment Page	C
Adjustment Address	4E
Specified Value	The Main and Sub channel distortion rate should be almost the same (within $\pm 1\%$) and minimum.

Note: The data of page: 0, address: 10 must be "00".

Adjusting method:

- 1) Select page: 0, address: 01, and set data: 01.
- 2) Set the Hi-Fi SOUND switch (menu display) to "2".
- 3) Select page: C, address: 4E, change the data and minimize the distortion rate.
- 4) Press the PAUSE button.
- 5) Set the Hi-Fi SOUND switch (menu display) to "1".
- 6) Select page: C, address: 4E, change the data and minimize the distortion rate.
- 7) Press the PAUSE button.
- 8) Repeat steps 2) to 7) and set the data of address: 4E so that the distortions rates when the Hi-Fi SOUND switch is set to "2" and set to "1" respectively are almost the same and minimum.
- 9) Press the PAUSE button.
- 10) Select page: 0, address: 01, and set data: 00.
- 11) Set the Hi-Fi SOUND switch to "STEREO".

2. Hi8/Standard8 AFM 1.5 MHz Deviation Adjustment (VC-278 board)

Adjust to the optimum 1.5MHz audio FM signal deviation.

If the adjustment is not correct, its playback level will differ from that of other units.

Mode	Playback
Signal	Hi8/Standard8 alignment tape: For checking AFM stereo operation Monoscope section (WR5-9NS (NTSC), WR5-9CS (PAL))
Measurement Point	AUDIO/VIDEO jack left or right
Measuring Instrument	Audio level meter
Adjustment Page	C
Adjustment Address	4C
Specified Value	$-7.5 \pm 2.0\text{dB}$ s

Note: The data of page: 0, address: 10 must be "00".

Adjusting method:

- 1) Select page: 0, address: 01, and set data: 01.
- 2) Set the Hi-Fi SOUND switch (menu display) to "1".
- 3) Select page: C, address: 4C, change the data and set the 400Hz signal level to the specified value.
- 4) Press the PAUSE button.
- 5) Set the Hi-Fi SOUND switch (menu display) to "STEREO".
- 6) Select page: 0, address: 01, and set data: 00.

3. Hi8/Standard8 AFM 1.7 MHz Deviation Adjustment (VC-278 board)

Adjust to the optimum 1.7MHz audio FM signal deviation.

If improper, this causes deteriorated separation (with stereo signal).

Mode	Playback
Signal	Hi8/Standard8 alignment tape: For checking AFM stereo operation Monoscope section (WR5-9NS (NTSC), WR5-9CS (PAL))
Measurement Point	AUDIO/VIDEO jack left or right
Measuring Instrument	Oscilloscope
Adjustment Page	C
Adjustment Address	4D
Specified Value	$-7.5 \pm 2.0\text{dB}$ s

Note: The data of page: 0, address: 10 must be "00".

Adjusting method:

- 1) Select page: 0, address: 01, and set data: 01.
- 2) Set the Hi-Fi SOUND switch (menu display) to "2".
- 3) Select page: C, address: 4D, change the data and set the 1kHz signal level to the specified value.
- 4) Press the PAUSE button.
- 5) Set the Hi-Fi SOUND switch (menu display) to "STEREO".
- 6) Select page: 0, address: 01, and set data: 00.

4. Digital8 Playback Level Check

Mode	Playback
Signal	Digital8 alignment tape: For audio operation check (WR5-3ND (NTSC), WR5-3CD (PAL))
Measurement Point	AUDIO/VIDEO jack left or right
Measuring Instrument	Audio level meter and frequency counter
Specified Value	32 kHz mode: 1 kHz, $+3.0 \pm 2.0\text{dB}$ s 48 kHz mode: 1 kHz, $+3.0 \pm 2.0\text{dB}$ s 44.1 kHz mode: The 7.35kHz signal level during EMP OFF is $+2.0 \pm 2.0\text{dB}$ s. The 7.35kHz signal level during EMP ON is -6 ± 2 dB from the signal level during EMP OFF.

Checking Method:

- 1) Check that the playback signal level is the specified value.

5. Overall Level Characteristics Check

Mode	Recording and playback
Signal	400Hz, -66dB s signal: MIC jack left and right
Measurement Point	AUDIO/VIDEO jack left or right
Measuring Instrument	Audio level meter
Specified Value	$-7.5 \pm 3.0\text{dB}$ s

Checking Method:

- 1) Input the 400Hz, -66dB s signal in the MIC jack left and right.
- 2) Record the signal.
- 3) Playback the recorded section.
- 4) Check that the 400Hz signal level is the specified value.

6. Overall Distortion Check

Mode	Recording and playback
Signal	400Hz, -66dB s signal: MIC jack left and right
Measurement Point	AUDIO/VIDEO jack left or right
Measuring Instrument	Audio distortion meter
Specified Value	Below 0.4% (200Hz to 6kHz BPF ON)

Checking Method:

- 1) Input the 400Hz, -66dB s signal in the MIC jack left and right.
- 2) Record the signal.
- 3) Playback the recorded section.
- 4) Check that the distortion is the specified value.

7. Overall Noise Level Check

Mode	Recording and playback
Signal	No signal: MIC jack left and right
Measurement Point	AUDIO/VIDEO jack left or right
Measuring Instrument	Audio level meter
Specified Value	Below -45dBs (IHF-A filter ON, 20kHz LPF ON)

Checking Method:

- 1) Connect the left terminal of MIC jack and its ground terminal with a jumper wire.
- 2) Connect the right terminal of MIC jack and its ground terminal with a jumper wire.
- 3) Record the signal.
- 4) Playback the recorded section.
- 5) Check that the noise level is the specified value.
- 6) Remove the jumper wires.

8. Overall Separation Check

Mode	Recording and playback
Signal	No signal: MIC jack <left> [right] 400Hz, -66dBs signal: MIC jack <right> [left]
Measurement Point	AUDIO/VIDEO jack <left> [right]
Measuring Instrument	Audio level meter
Specified Value	Below -40dBs

< >: Left channel check

[]: Right channel check

Checking Method:

- 1) Connect the <left> [right] terminal of MIC jack and its ground terminal with a jumper wire.
- 2) Input the 400Hz, -66dBs signal in the MIC jack <right> [left].
- 3) Record the signal.
- 4) Playback the recorded section.
- 5) Check that the signal level of the AUDIO/VIDEO jack <left> [right] is the specified value.
- 6) Remove the jumper wire.

5-4. SERVICE MODE

4-1. ADJUSTMENT REMOTE COMMANDER

The adjustment remote commander is used for changing the calculation coefficient in signal processing, EVR data, etc. The adjustment remote commander performs bi-directional communication with the unit using the remote commander signal line (LANC). The resultant data of this bi-directional communication is written in the non-volatile memory.

1. Using the Adjustment Remote Commander

- 1) Connect the adjustment remote commander to the LANC terminal.
- 2) Set the HOLD switch of the adjustment remote commander to "HOLD" (SERVICE position). If it has been properly connected, the LCD on the adjustment remote commander will display as shown in Fig. 5-4-1.



Fig. 5-4-1.

- 3) Operate the adjustment remote commander as follows.

- Changing the page

The page increases when the EDIT SEARCH+ button is pressed, and decreases when the EDIT SEARCH- button is pressed. There are altogether 20 pages, from 0 to F, 1B, 1C, 1E, 1F (Note1).

Hexadecimal notation	0 1 2 3 4 5 6 7 8 9 A B C D E F
LCD Display	0 1 2 3 4 5 6 7 8 9 A b c d E F
Decimal notation conversion value	0 1 2 3 4 5 6 7 8 9 10 11 12 13 14 15

- Changing the address

The address increases when the FF (▶▶) button is pressed, and decreases when the REW (◀◀) button is pressed. There are altogether 256 addresses, from 00 to FF.

- Changing the data (Data setting)

The data increases when the PLAY (▶) button is pressed, and decreases when the STOP (■) button is pressed. There are altogether 256 data, from 00 to FF.

- Writing the adjustment data

The PAUSE button must be pressed to write the adjustment data (8, A, B, C, D, E, F, 1B, 1C, 1E, 1F page) in the nonvolatile memory. (The new adjusting data will not be recorded in the nonvolatile memory if this step is not performed.)(Note2)

- 4) After completing all adjustments, turn off the main power supply (8.4 V) once.

Note: When reading or writing the 1B, 1C, 1E, 1F page data, select page: 0, address: 10, and set data: 01, then select B, C, E or F page. The 1B, 1C, 1E or 1F page can be chosen by this data setting. After reading or writing, reset the data of page: 0, address: 10 to "00".

2. Precautions Upon Using

the Adjustment Remote Commander

Mishandling of the adjustment remote commander may erase the correct adjustment data at times. To prevent this, it is recommended that all adjustment data be noted down before beginning adjustments and new adjustment data after each adjustment.

4-2. DATA PROCESS

The calculation of the DDS display and the adjustment remote commander display data (hexadecimal notation) are required for obtaining the adjustment data of some adjustment items. In this case, after converting the hexadecimal notation to decimal notation, calculate and convert the result to hexadecimal notation, and use it as the adjustment data. Indicates the hexadecimal-decimal conversion table.

Hexadecimal-decimal Conversion Table																②
Lower digit of hexadecimal Upper digit of hexadecimal	0	1	2	3	4	5	6	7	8	9	A (A)	B (B)	C (C)	D (D)	E (E)	F (F)
0	0	1	2	3	4	5	6	7	8	9	10	11	12	13	14	15
1	16	17	18	19	20	21	22	23	24	25	26	27	28	29	30	31
2	32	33	34	35	36	37	38	39	40	41	42	43	44	45	46	47
3	48	49	50	51	52	53	54	55	56	57	58	59	60	61	62	63
4	64	65	66	67	68	69	70	71	72	73	74	75	76	77	78	79
5	80	81	82	83	84	85	86	87	88	89	90	91	92	93	94	95
6	96	97	98	99	100	101	102	103	104	105	106	107	108	109	110	111
7	112	113	114	115	116	117	118	119	120	121	122	123	124	125	126	127
8	128	129	130	131	132	133	134	135	136	137	138	139	140	141	142	143
9	144	145	146	147	148	149	150	151	152	153	154	155	156	157	158	159
A (A)	160	161	162	163	164	165	166	167	168	169	170	171	172	173	174	175
① B (B)	176	177	178	179	180	181	182	183	184	185	186	187	188	189	190	191
C (C)	192	193	194	195	196	197	198	199	200	201	202	203	204	205	206	207
D (D)	208	209	210	211	212	213	214	215	216	217	218	219	220	221	222	223
E (E)	224	225	226	227	228	229	230	231	232	233	234	235	236	237	238	239
F (F)	240	241	242	243	244	245	246	247	248	249	250	251	252	253	254	255

Note: The characters shown in the parenthesis () shown the display on the adjustment remote commander.

(Example) If the DDS display or the adjustment remote commander shows BD (B D);
Because the upper digit of the adjustment number is B (B), and the lower digit is D (D), the meeting point “189” of ① and ② in the above table is the corresponding decimal number.

Table 5-4-1.

4-3. SERVICE MODE

Note: Before performing the adjustments, check the data of page : 0, address: 10 is "00". If not, set data: 00 to this address.

Additional note on adjustment

Note1: After the completion of the all adjustments, cancel the service mode by either of the following ways.

1) After data on page: C and D is restored, unplug the main power supply and remove the coin lithium battery. (In this case, date and time and menu setting have been set by users are canceled. Perform resetting.)

2) After data on page: C and D is restored, select page: 0, address: 01, and return the data to 00. And when data on page:2 and 3 are changed, return data to the original condition.

Note2: Before performing the adjustments, check the data of page: 0, address: 10 is "00". If not, set data: 00 to this address.

1. Setting the Test Mode

Page C	Address 3E
--------	------------

Data	Function
00	Normal
01	Test mode Various emergency prohibitions and releases Drum emergency, capstan emergency, loading motor emergency, reel emergency, tape top and end, DEW detection

Page D	Address 10
--------	------------

Data	Function
00	Normal
01	Forced camera power ON
02	Forced VTR power ON

- Before setting the data , select page: 0, address: 01, and set data: 01.
- For page C and D, the data set will be recorded in the non-volatile memory by pressing the PAUSE button of the adjustment remote commander. In this case, take note that the test mode will not be exited even when the main power is turned off (8.4Vdc).
- After completing adjustments/repairs, be sure to return the data of page: C address: 3E to 00, and the data of page: D address: 10 to 00, and press the PAUSE button of the adjustment remote commander. And select page: 0, address: 01, and set data: 00.

2. Emergence Memory Address

Page C	Address F4 to FF
--------	------------------

Address	Contents
F4	EMG code when first error occurs
F6	Upper: MSW code when shift starts when first error occurs Lower: MSW code when first error occurs
F7	Lower: MSW code to be moved when first error occurs
F8	EMG code when second error occurs
FA	Upper: MSW code when shift starts when second error occurs Lower: MSW code when second error occurs
FB	Lower: MSW code to be moved when second error occurs
FC	EMG code when last error occurs
FE	Upper: MSW code when shift starts when last error occurs Lower: MSW code when last error occurs
FF	Lower: MSW code to be moved when last error occurs

When no error occurs in this unit, data "00" is written in the above addresses (F4 to FF). when first error occurs in the unit, the data corresponding to the error is written in the first emergency address (F4 to F7). In the same way, when the second error occurs, the data corresponding to the error is written in the second emergency address (F8 to FB).

Finally, when the last error occurs, the data corresponding to the error is written in the last emergency address (FC to FF).

Note : After completing adjustments, be sure to initialize the data of addresses F4 to FF to "00".

Initializing method:

- 1) Select page: 0, address: 01, and set data: 01.
- 2) Select page: 3, address: 01, set data: 37, and press the PAUSE button.
- 3) Select page: 0, address: 01, and set data: 00.

2-1. EMG Code (Emergency Code)

Codes corresponding to the errors which occur are written in C page, addresses F4, F8 and FC. The type of error indicated by the code are shown in the following table.

Code	Emergency Type
00	No error
10	Loading motor emergency during loading
11	Loading motor emergency during unloading
22	T reel emergency during normal rotation
23	S reel emergency during normal rotation
24	T reel emergency (Short circuit between S reel terminal and T reel terminal)
30	FG emergency at the start up of the capstan
40	FG emergency at the start up of the drum
42	FG emergency during normal rotation of the drum

3. Bit Value Discrimination

Bit values must be discriminated using the display data of the adjustment remote commander for the following items. Use the table below to discriminate if the bit value is "1" or "0".

Display on the adjustment remote commander

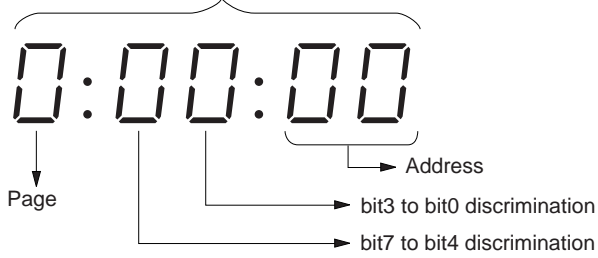

(Example) If the remote commander display is "8E", bit value from bit 7 to bit 4 can be discriminated from the column **(A)**, and those from bit 3 to bit 0 from column **(B)**.

Display on the adjustment remote commander	Bit values			
	bit3 or bit7	bit2 or bit6	bit1 or bit5	bit0 or bit4
0	0	0	0	0
1	0	0	0	1
2	0	0	1	0
3	0	0	1	1
4	0	1	0	0
5	0	1	0	1
6	0	1	1	0
7	0	1	1	1
(A) 8	1	0	0	0
9	1	0	0	1
A (<i>A</i>)	1	0	1	0
B (<i>B</i>)	1	0	1	1
C (<i>C</i>)	1	1	0	0
D (<i>D</i>)	1	1	0	1
(B) E (<i>E</i>)	1	1	1	0
F (<i>F</i>)	1	1	1	1

4. Switch check (1)

Page 7	Address 0E
--------	------------

Bit	Function	When bit value = 1	When bit value = 0
0	POWER SW (VTR MODE SW) (SS-1380 block S001)	ON (VCR/PLAYER)	OFF
1	POWER SW (CAM MODE SW) (SS-1380 block S001)	ON (CAMERA)	OFF
2	START/STOP SW (SS-1380 block S002)	ON	OFF
3	EJECT SW (SS-1380 block S003)	ON	OFF
4	CC DOWN SW (Mechanism chassis)	ON (DOWN)	OFF (UP)
5	PHOTO FREEZE SW (SS-1380 block S004)	ON	OFF
6	POWER SW (PHOTO STBY SW) (SS-1380 block S001)	ON (MEMORY)	OFF
7			

Using method:

- 1) Select page: 7, address: 0E.
- 2) By discriminating the bit value of display data, the state of the switch can be discriminated.

5. Switch check (2)

Page 7	Address 0C
--------	------------

Bit	Function	When bit value = 1	When bit value = 0
1	AUDIO/VIDEO jack (FP-410 flexible J201)	Used	Not used
2	S VIDEO jack (FP-410 flexible J201)	Used	Not used
3	MIC jack (FP-411 flexible J302)	Used	Not used

Using method:

- 1) Select page: 7, address: 0C.
- 2) By discriminating the bit value of display data, the state of the switch can be discriminated.

6. Switch check (3)

Page 3	Address 61
--------	------------

Bit	Function	When bit value = 1	When bit value = 0
6	HEADPHONS jack (FP-411 flexible J301)	Used	Not used

Using method:

- 1) Select page: 3, address: 61.
- 2) By discriminating the bit value of display data, the state of the switch can be discriminated.

7. Switch check (4)

Page 2	Address 60 to 65
--------	------------------

Using method:

- 1) Select page: 2, address: 60 to 65.
- 2) By discriminating the display data, the pressed key can be discriminated.

Address	Data							
	00 to 0C	0D to 24	25 to 3F	40 to 5D	5E to 81	82 to AA	AB to D7	D8 to FF
60 (KEY AD0) (IC5001 59)	SUPER NIGHT SHOT (FK-2500) (S401)	STOP (FK-2500) (S404)	FF (FK-2500) (S407)	REW (FK-2500) (S409)	PLAY (FK-2500) (S403)	REC (FK-2500) (S406,408)		No key input
61 (KEY AD1) (IC5001 60)	PAUSE (FK-2500) (S405)	FOCUS (CF-2500) (S004)	BACK LIGHT (CF-2500) (S016)	FADER (CF-2500) (S010)	EXPOSURE (CF-2500) (S027)	MENU EXECUTE (CF-2500) (S007)	PANEL CLOSE (CF-2500) (S001)	PANEL OPEN (CF-2500) (S001)
62 (KEY AD2) (IC5001 61)		EDIT SEARCH + (CF-2500) (S024)	EDIT SEARCH - (CF-2500) (S025)					No key input
63 (KEY AD3) (IC5001 65)	END SEARCH (CF-2500) (S003)	PB ZOOM (CF-2500) (S006)	TITLE (CF-2500) (S009)	MENU (CF-2500) (S012)	VOLUME + (CF-2500) (S015)	VOLUME - (CF-2500) (S022)	DISPLAY (CF-2500) (S019)	No key input
64 (KEY AD4) (IC5001 66)	MEMORY INDEX (CF-2500) (S026)	MPEG PLAY (CF-2500) (S005)	MEMORY MIX (CF-2500) (S029)	MEMORY DELETE (CF-2500) (S028)	MEMORY + (CF-2500) (S013)	MEMORY - (CF-2500) (S017)	MEMORY PLAY (CF-2500) (S018)	No key input
65 (KEY AD5) (IC5001 67)		PHOTO (PHOTO START) (SS-1380) (S004)	PANEL REVERSE (FP-412) (S601)					PANEL NORMAL (FP-412) (S601)

8. Record of Use check (1)

Page 7	Address C8 to CD
--------	------------------

Address	Function	Remarks
C8	User initial power	After setting the clock, set the date of power on next
C9	on date	
CA	(BCD code)	
CB	Final condensation	
CC	occurrence date	
CD	(BCD code)	

Using method:

- 1) The record of use data is displayed at addresses: A2 to AA.
Note: This data will be kept even if the lithium battery (CF-2500 block BT101) is removed.

9. Record of Use check (2)

Page 7	Address A7 to A9
--------	------------------

Address	Function	Remarks
A7	Drum rotation counted time	Hour (H) 100000 place digit and 10000 place digit (decimal digit)
A8	(BCD code)	Hour (M) 1000 place digit and 100 place digit (decimal digit)
A9		Hour (L) 10 place digit and 1 place digit (decimal digit)

Using method:

- 1) The record of use data is displayed at addresses: A7 to A9.

Note: This data will be kept even if the lithium battery (CF-2500 block BT101) is removed.

Initializing method:

- 1) Select page: 7, address: 00, set data: 71, and press PAUSE button.
- 2) Select page: 7, address: 01, set data: 71, and press PAUSE button.
- 3) Select page: 7, address: 02, and check the data is "01".

10. Record of Self-diagnosis check

Page 7	Address B0 to C6
--------	------------------

Address	Self-diagnosis code
B0	"Repaired by" code (Occurred 1st time) *1
B1	"Block function" code (Occurred 1st time)
B2	"Detailed" code (Occurred 1st time)
B4	"Repaired by" code (Occurred 2nd time) *1
B5	"Block function" code (Occurred 2nd time)
B6	"Detailed" code (Occurred 2nd time)
B8	"Repaired by" code (Occurred 3rd time) *1
B9	"Block function" code (Occurred 3rd time)
BA	"Detailed" code (Occurred 3rd time)
BC	"Repaired by" code (Occurred 4th time) *1
BD	"Block function" code (Occurred 4th time)
BE	"Detailed" code (Occurred 4th time)
C0	"Repaired by" code (Occurred 5th time) *1
C1	"Block function" code (Occurred 5th time)
C2	"Detailed" code (Occurred 5th time)
C4	"Repaired by" code (Occurred the last time) *1
C5	"Block function" code (Occurred the last time)
C6	"Detailed" code (Occurred the last time)

*1 : "01" → "C", "03" → "E"

Using method:

- 1) The past self-diagnosis codes are displayed at addresses: BC to C6. Refer to "SELF-DIAGNOSIS FUNCTION" for detail of the self-diagnosis code.

Note: This data will be kept even if the lithium battery (CF-2500 block BT101) is removed.



SECTION 6 REPAIR PARTS LIST

6-1. EXPLODED VIEWS

NOTE:

- -XX, -X mean standardized parts, so they may have some differences from the original one.
- Items marked "*" are not stocked since they are seldom required for routine service. Some delay should be anticipated when ordering these items.
- The mechanical parts with no reference number in the exploded views are not supplied.

- Abbreviation
- CND : Canadian model
- KR : Korea model
- JE : Tourist model
- AUS : Australian model
- HK : Hong Kong model
- CH : Chinese model
- EE : East European model
- NE : North European model
- RU : Russian model
- AR : Argentina model

The components identified by mark \triangle or dotted line with mark \triangle are critical for safety. Replace only with part number specified.

Les composants identifiés par une marque \triangle sont critiques pour la sécurité. Ne les remplacer que par une pièce portant le numéro spécifié.

6-1-1. OVERALL SECTION

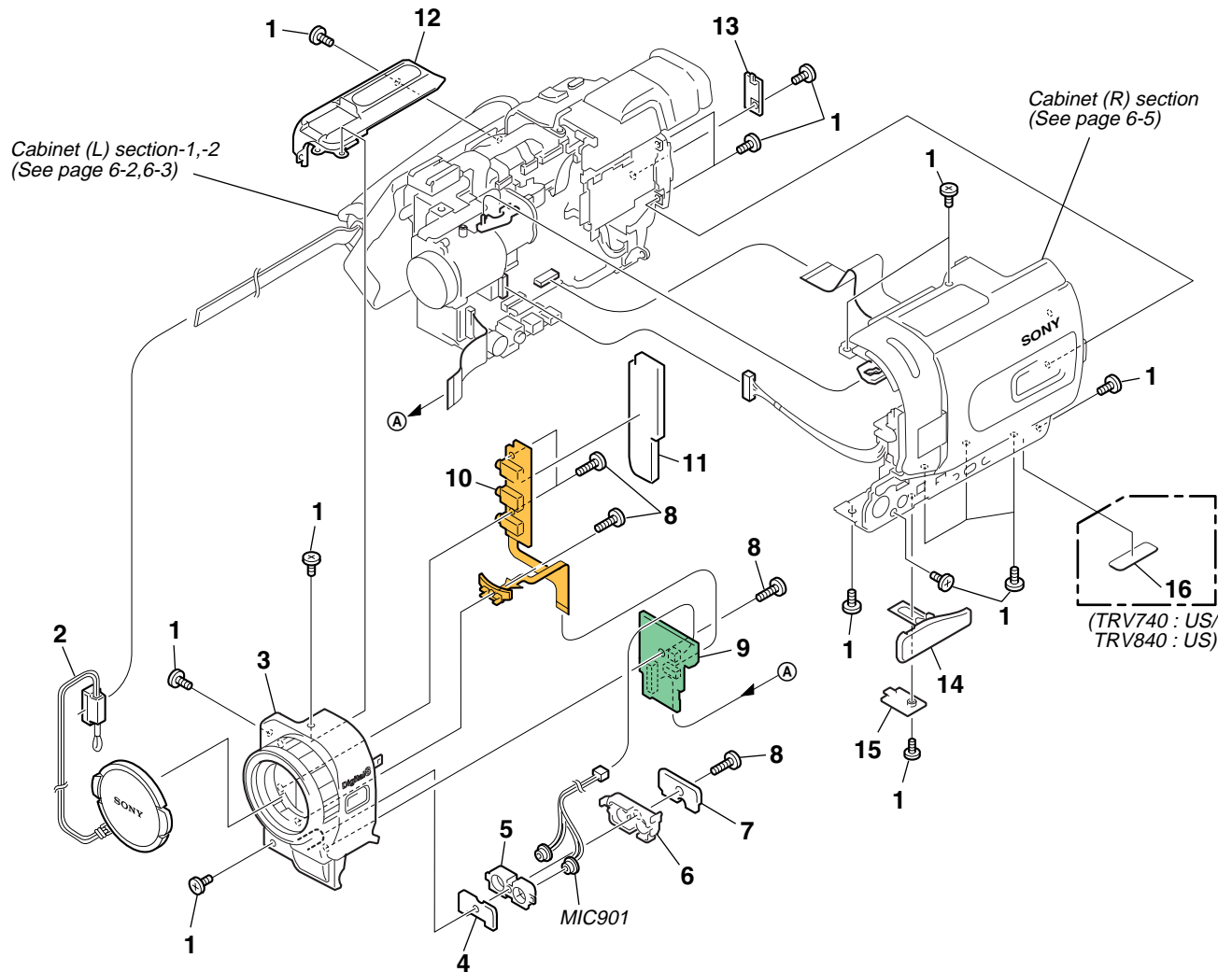

Ref. No.	Part No.	Description
1	3-067-347-01	MI SCREW M2 (H)
2	X-3949-376-1	CAP (N) ASSY, LENS
3	X-3952-247-1	PANEL ASSY (25), F
4	3-072-279-01	CUSHION (F), MICROPHONE
5	3-072-278-01	HOLDER, MICROPHONE
6	3-072-277-01	RETAINER, MICROPHONE
7	3-072-307-01	SHEET, MICROPHONE
8	3-065-567-01	TAPPING (M1.7)
9	A-7078-047-A	SI-032 BOARD, COMPLETE

Ref. No.	Part No.	Description
10	1-683-627-21	FP-411 FLEXIBLE BOARD
11	3-072-309-01	CUSHION (1), F
12	3-065-326-01	CABINET (UPPER)
13	3-072-271-01	LID (BT), CPC
14	3-072-343-01	COVER, JACK
15	3-072-344-01	RETAINER, JACK COVER
* 16	3-704-367-01	LABEL (TRV740:US/TRV840:US)
MIC901	1-542-477-11	MICROPHONE

6-1-2. CABINET (L) SECTION-1

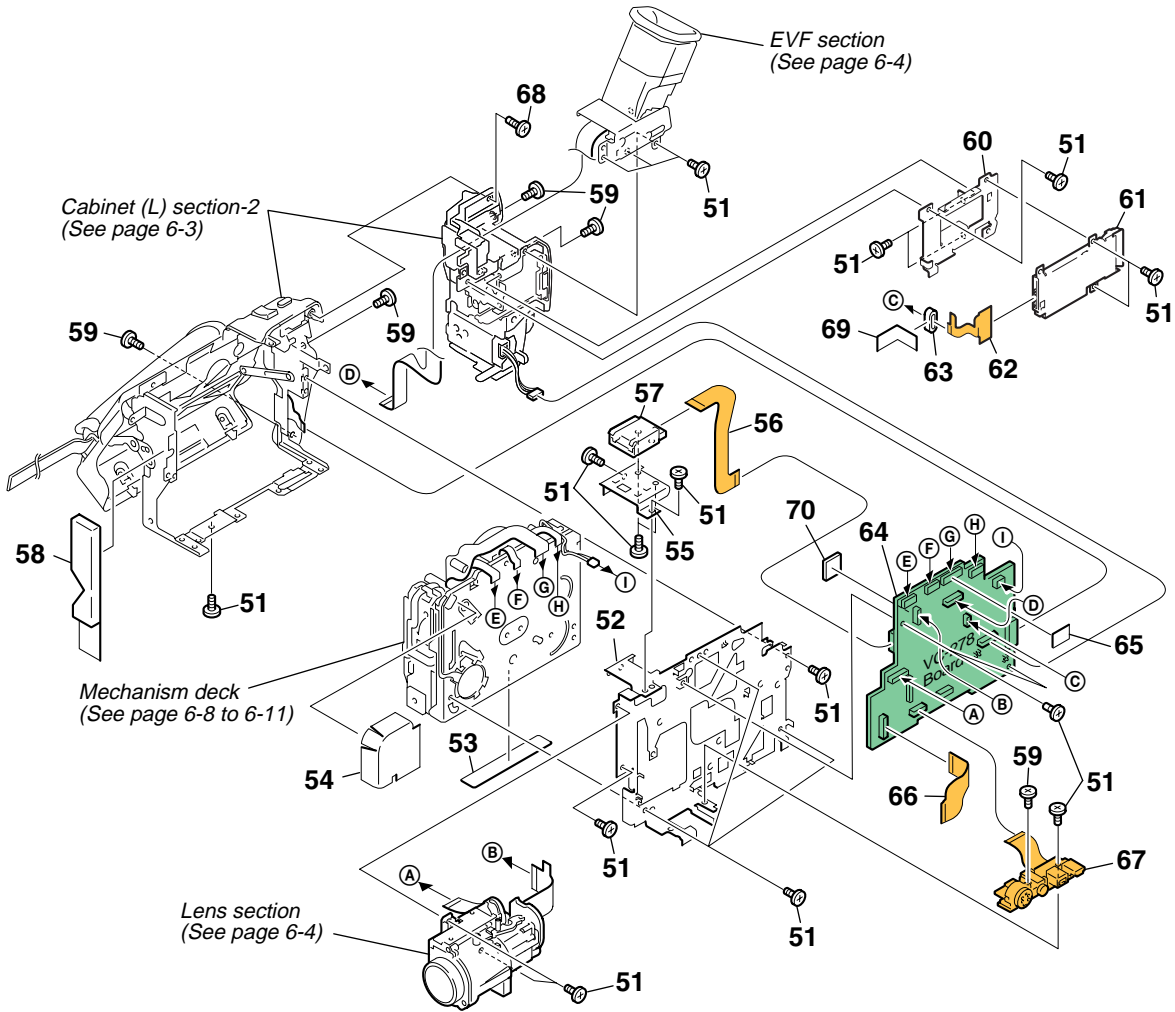

Ref. No.	Part No.	Description
51	4-974-725-01	SCREW (M1.7X2.5), P
52	3-072-267-01	FRAME, MD
53	3-065-662-01	LABEL, LS CAUTION
54	3-066-169-01	SHEET, MD
55	3-072-268-01	FRAME, SHOE
56	1-680-118-11	FP-264 FLEXIBLE BOARD
57	1-815-124-11	CONNECTOR, EXTERNAL (HOT SHOE)
58	3-072-308-01	COVER, MD
59	3-067-347-01	MI SCREW M2 (H)
60	3-072-273-01	HOLDER, MS
61	1-816-271-11	CONNECTOR, MEMORY STICK 10P
62	1-683-625-11	FP-409 FLEXIBLE BOARD
63	1-500-226-11	BEAD, FERRITE

Ref. No.	Part No.	Description
64	A-7012-212-A	VC-278 (GNA) BOARD, COMPLETE (SERVICE) (TRV740/TRV840)
64	A-7012-362-A	VC-278 (GPA0) BOARD, COMPLETE (SERVICE) (TRV738E)
64	A-7012-363-A	VC-278 (GPA) BOARD, COMPLETE (SERVICE) (TRV740E)
65	3-066-759-01	SHEET, VC
66	1-683-623-11	FP-406 FLEXIBLE BOARD
67	1-683-626-21	FP-410 FLEXIBLE BOARD
68	3-065-567-01	TAPPING (M1.7)
69	3-941-343-21	TAPE (A)
70	3-075-983-01	SHEET (25) 2, M

6-1-3. CABINET (L) SECTION-2

ns : not supplied

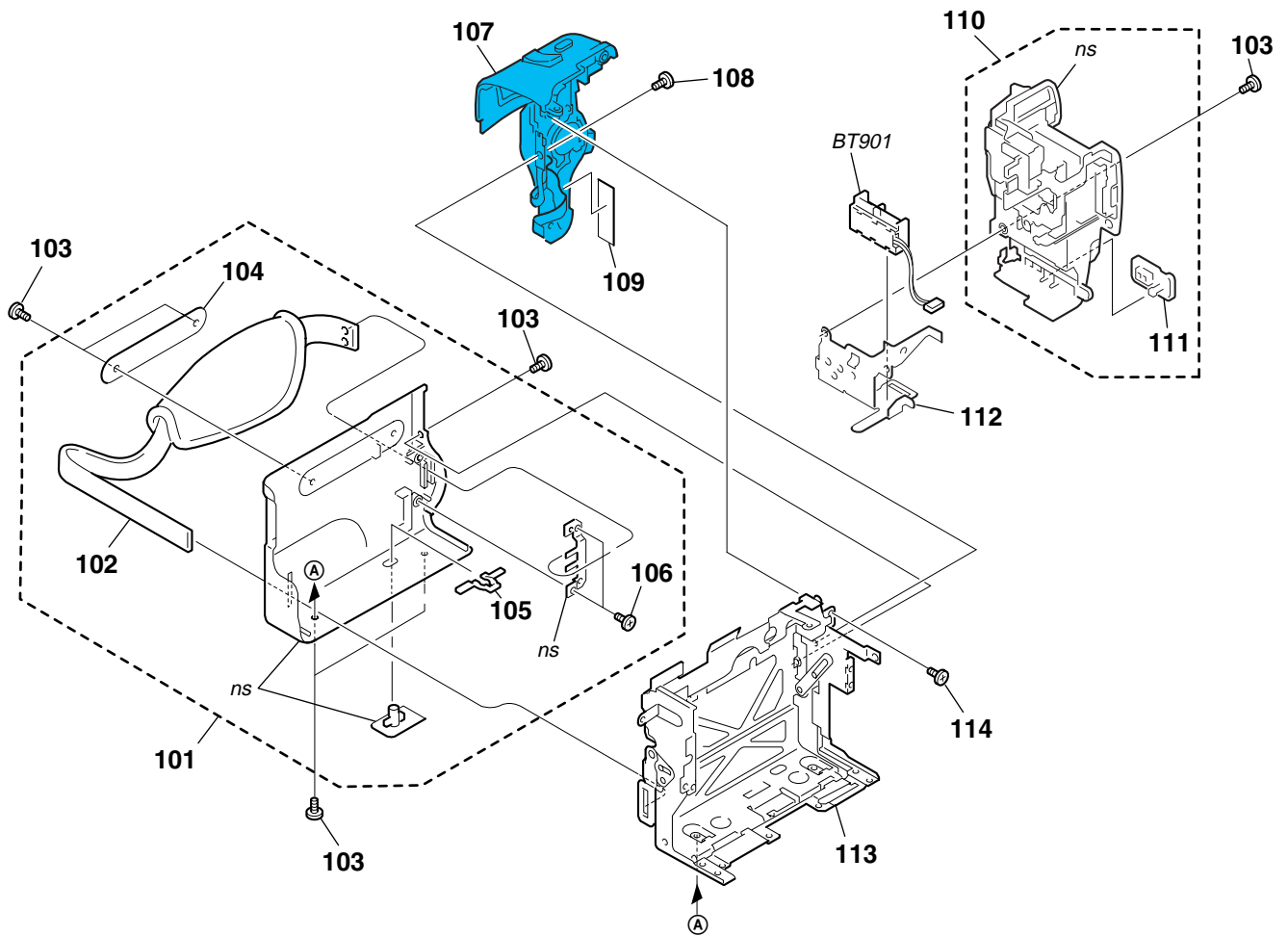

Ref. No.	Part No.	Description	Ref. No.	Part No.	Description
101	X-3951-159-1	CABINET (L) ASSY	108	4-974-725-01	SCREW (M1.7X2.5), P
102	3-052-815-01	BELT (ES), GRIP	109	3-941-343-21	TAPE (A)
103	3-067-347-01	MI SCREW M2 (H)	110	X-3952-148-1	PANEL ASSY (MS), BATTERY
104	3-065-308-01	LABEL (L)	111	3-072-305-01	LID (2500), JACK
105	3-978-765-01	SLIDER, G LOCK	112	3-072-274-01	SHEET METAL (LOWER), STRAP
106	3-713-791-01	SCREW (M1.7X4), TAPPING, P2	113	X-3952-136-1	FRAME ASSY (25), CS
107	1-476-415-11	SWITCH BLOCK, CONTROL (SS-1380)	114	3-065-567-01	TAPPING (M1.7)
		(TRV740/TRV740E/TRV840)	BT901	1-694-772-11	TERMINAL BOARD, BATTERY
107	1-476-415-31	SWITCH BLOCK, CONTROL (SS-1380)			
		(TRV738E)			

6-1-4. LENS, EVF SECTION

ns : not supplied

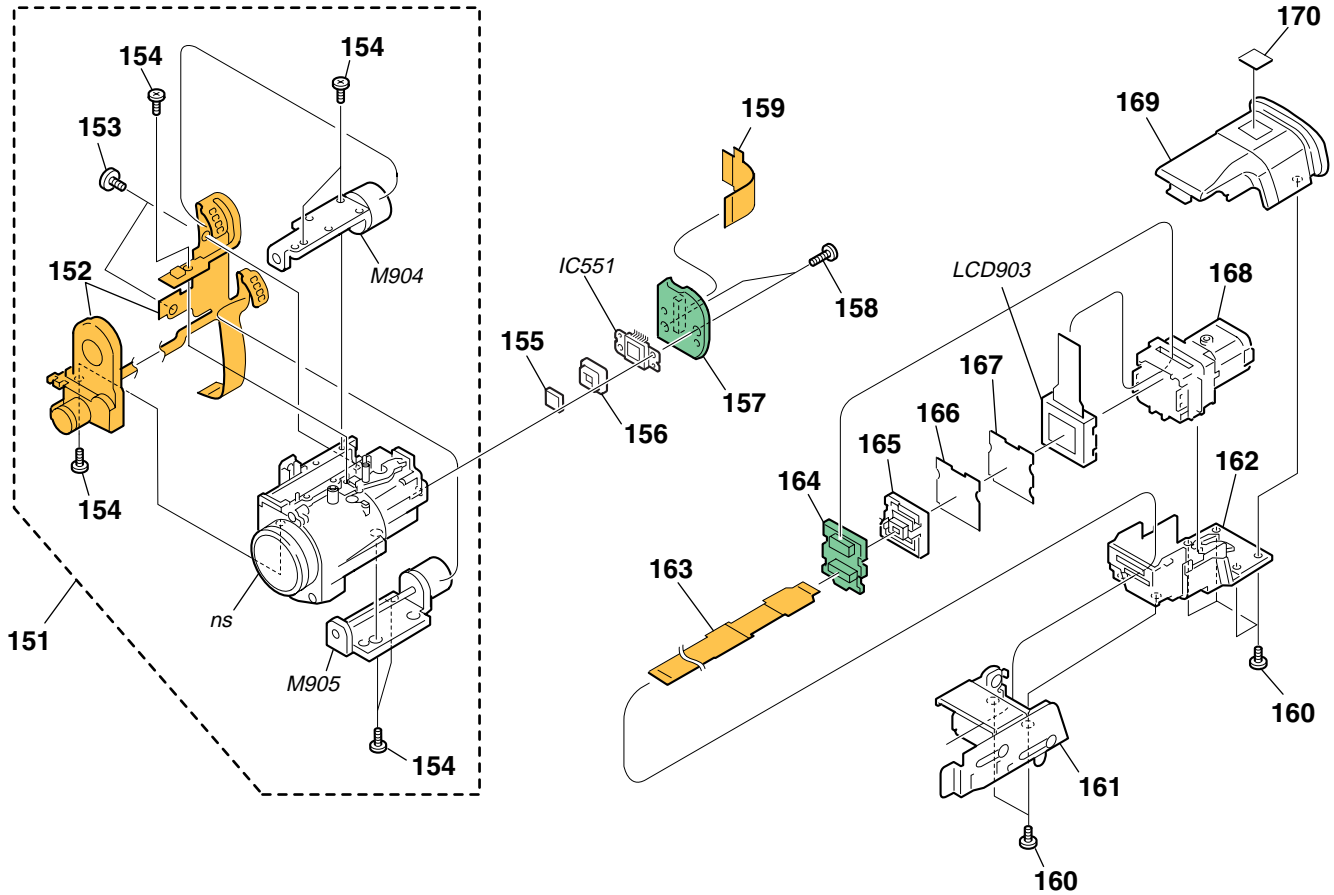

Be sure to read "Precautions upon replacing CCD imager" on page 4-7 when changing the CCD imager.

Ref. No.	Part No.	Description
151	8-848-754-01	DEVICE, LENS LSV-740A
152	1-758-743-11	IRIS (IR740)
153	3-056-022-01	TAPPING (B1.7X3.5), HEAD
154	3-713-791-35	SCREW (M1.7X5), TAPPING, P2
155	1-758-569-11	FILTER BLOCK, OPTICAL
156	3-053-973-01	RUBBER (W), SEAL
157	A-7078-109-A	CD-358 BOARD, COMPLETE
158	3-318-203-11	SCREW (B1.7X6), TAPPING
159	1-680-120-11	FP-317 FLEXIBLE BOARD
160	3-065-567-01	TAPPING (M1.7)
161	X-3951-165-1	HINGE ASSY, VF
162	X-3952-143-1	CABINET (LOWER) ASSY, EVF

Ref. No.	Part No.	Description
163	1-683-624-11	FP-407 FLEXIBLE BOARD
164	A-7078-049-A	LB-076 BOARD, COMPLETE
165	3-065-058-01	GUIDE, LAMP
166	3-072-211-01	ILLUMINATOR
167	3-072-210-01	SHEET, PRISM
168	X-3952-214-1	LENS (B) ASSY, VF
169	X-3952-142-1	CABINET (UPPER) ASSY, EVF
170	3-065-376-01	LABEL (138), B
IC551	A-7012-228-A	CCD BLOCK ASSY (CCD IMAGER)
LCD903	8-753-028-49	LCX032AP-5
M904	1-763-806-11	MOTOR, STEPPING Z740A (ZOOM)
M905	1-763-807-11	MOTOR, STEPPING F740A (FOCUS)

6-1-5. CABINET (R) SECTION

ns : not supplied

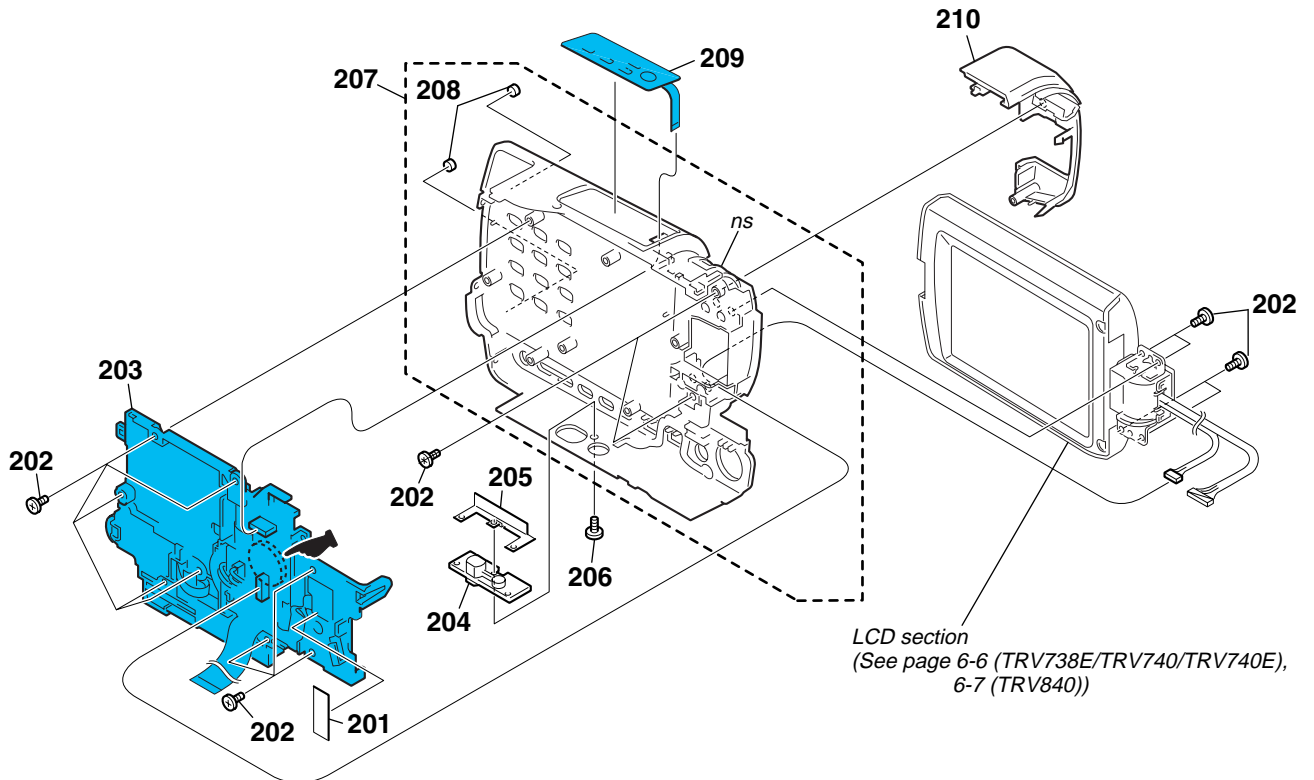

 : The printed wiring board of the Control switch block (CF-2500) on which BT001 (lithium battery) is mounted, is not shown.

CAUTION :

Danger of explosion if battery is incorrectly replaced.
Replace only with the same or equivalent type.

Ref. No.	Part No.	Description
201	3-941-343-21	TAPE (A)
202	3-948-339-61	TAPPING
203	1-477-085-21	SWITCH BLOCK, CONTROL (CF-2500)
204	3-065-373-01	SCREW (Y), TRIPOD
205	3-072-455-01	RETAINER, TRIPOD
206	3-067-347-01	MI SCREW M2 (H)
207	X-3952-140-1	CABINET R (2) ASSY (TRV740)
207	X-3952-146-1	CABINET R (2) ASSY (TRV738E)
207	X-3952-186-1	CABINET R (3) ASSY (TRV840)
207	X-3952-253-1	CABINET R (2) ASSY (TRV740E)

Ref. No.	Part No.	Description
208	3-959-978-02	CUSHION, PANEL
209	1-477-084-41	SWITCH BLOCK, CONTROL (FK-2500) (TRV738E)
209	1-477-084-51	SWITCH BLOCK, CONTROL (FK-2500) (TRV740/TRV740E/TRV840)
210	X-3952-141-1	RING (2) ASSY, ORNAMENTAL (TRV740)
210	X-3952-169-1	RING (2) ASSY, ORNAMENTAL (TRV738E/TRV740E)
210	X-3952-187-1	RING (3) ASSY, ORNAMENTAL (TRV840)

6-1-6. LCD SECTION (2.5 INCH LCD MODEL) (TRV738E/TRV740/TRV740E)

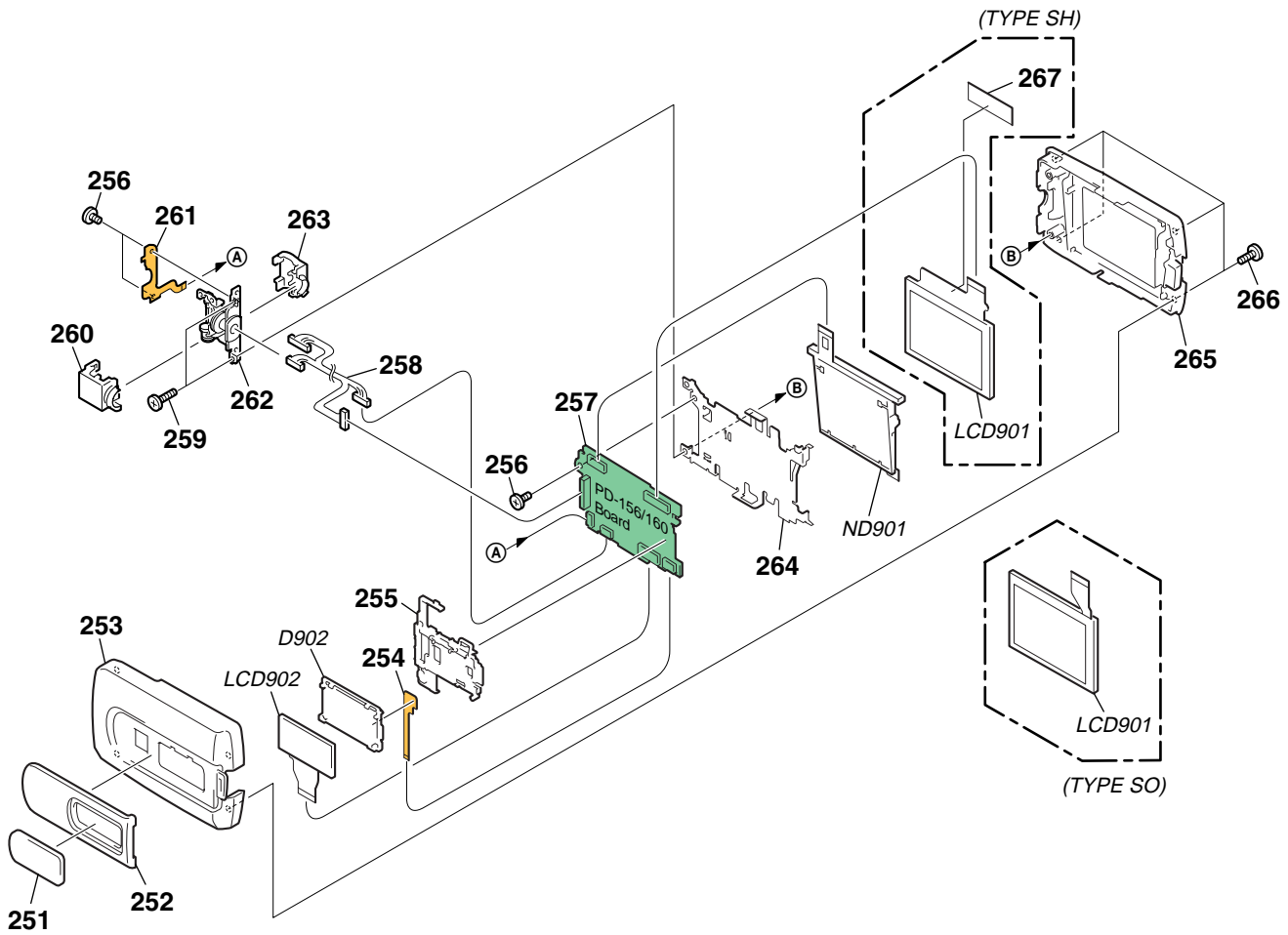

TYPE SH : TRV738E/TRV740E:AE,PEE,NE,RU
 TYPE SO : TRV740/TRV740E:E,HK,AUS,CH,JE

Ref. No.	Part No.	Description
251	3-072-272-11	WINDOW, LCD (TRV740)
251	3-072-272-21	WINDOW, LCD (TRV738E)
251	3-072-272-31	WINDOW, LCD (TRV740E)
252	X-3952-197-1	COVER (2) ASSY (M), CPC
253	3-072-341-11	CABINET (C (2)), P
254	1-683-629-11	FP-414 FLEXIBLE BOARD
255	3-072-286-01	HOLDER, LCD
256	4-974-725-01	SCREW (M1.7X2.5), P
257	A-7078-052-A	PD-160 (X6)(SO) BOARD, COMPLETE (TYPE SO MODEL)
257	A-7078-096-A	PD-156 (XC12)(SH) BOARD, COMPLETE (TYPE SH MODEL)
258	1-961-556-11	HARNESS (PD-117)
259	3-318-203-11	SCREW (B1.7X6), TAPPING
260	3-072-288-11	COVER (C), HINGE
261	1-683-628-21	FP-412 FLEXIBLE BOARD
262	X-3952-147-1	HINGE ASSY

Ref. No.	Part No.	Description
263	3-072-287-11	COVER (M), HINGE
264	3-072-403-01	FRAME (2), P
265	X-3952-151-1	P CABINET M (2) ASSY (M)
266	3-065-567-01	TAPPING (M1.7)
267	3-075-098-01	SHEET (SH), LCD INSULATING (TYPE SH MODEL)
△ D902	1-518-721-11	LIGHT, BACK
△ ND901	1-518-796-11	TUBE, FLUORESCENT,COLD CATHODE (TYPE SO MODEL)
△ ND901	1-518-798-21	TUBE, FLUORESCENT,COLD CATHODE (TYPE SH MODEL)
LCD901	1-803-853-21	INDICATOR MODULE LIQUID CRYST (TYPE SH MODEL)(Note)
LCD901	8-753-050-65	ACX308AK-1 (TYPE SO MODEL)(Note)
LCD902	A-7012-233-A	INDICATION LCD BLOCK ASSY

Note : LCD901 type check is refer to page 5-32 for "1-5-1. LCD Type Check" of this manual .

Note :
 The components identified by mark △ or dotted line with mark △ are critical for safety. Replace only with part number specified.

Note :
 Les composants identifiés par une marque △ sont critiques pour la sécurité. Ne les remplacer que par une pièce portant le numéro spécifié.

6-1-7. LCD SECTION (3.5 INCH LCD MODEL) (TRV840)

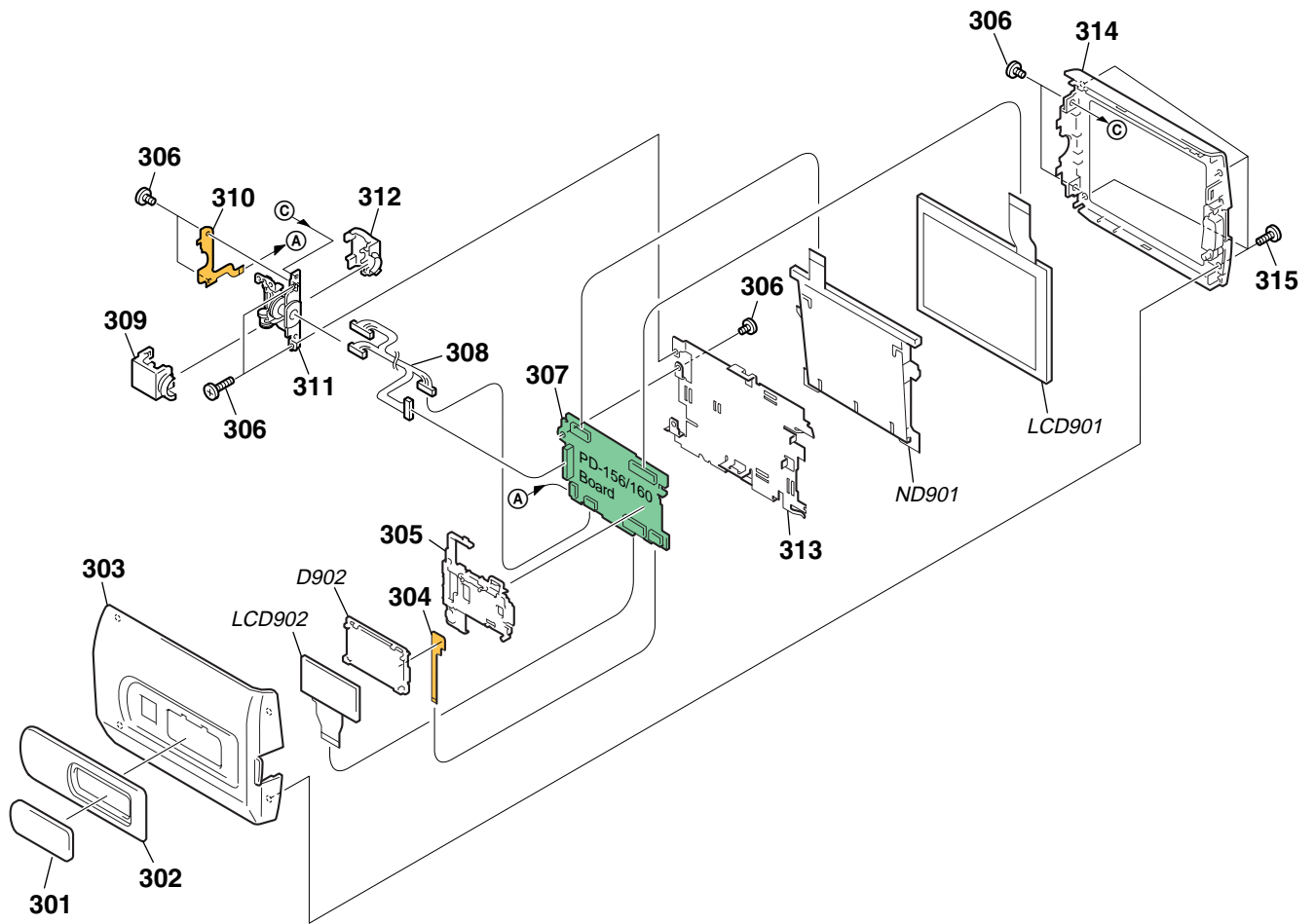

Ref. No.	Part No.	Description	Ref. No.	Part No.	Description
301	3-072-272-41	WINDOW, LCD	310	1-683-628-21	FP-412 FLEXIBLE BOARD
302	X-3952-198-1	COVER (3) ASSY (M), CPC	311	X-3952-147-1	HINGE ASSY
303	X-3952-153-1	CABINET (C) (3) ASSY (M), P	312	3-072-287-11	COVER (M), HINGE
304	1-683-629-11	FP-414 FLEXIBLE BOARD	313	3-072-289-01	FRAME (3), P
305	3-072-286-01	HOLDER, LCD	314	X-3952-152-1	CABINET (M) (3) ASSY (M), P
306	4-974-725-01	SCREW (M1.7X2.5), P	315	3-065-567-01	TAPPING (M1.7)
307	A-7078-145-A	PD-160 (ZS12)(SO) BOARD, COMPLETE (TYPE SO MODEL)	△ D902	1-518-721-11	LIGHT, BACK
307	A-7078-152-A	PD-156 (ZC12)(CA) BOARD, COMPLETE (TYPE CA MODEL)	△ ND901	1-517-855-31	TUBE, FLUORESCENT,COLD CATHODE
308	1-961-556-11	HARNESS (PD-117)	LCD901	1-803-861-31	INDICATOR MODULE LIQUID CRYST (TYPE CA MODEL)(Note)
309	3-072-288-11	COVER (C), HINGE	LCD901	8-753-051-00	ACX310AK-1 (TYPE SO MODEL)(Note)
			LCD902	A-7012-233-A	INDICATION LCD BLOCK ASSY

Note : LCD901 type check is refer to page 5-32 for "1-5-1. LCD Type Check" of this manual .

Note :
The components identified by mark \triangle or dotted line with mark \triangle are critical for safety. Replace only with part number specified.

Note :
Les composants identifiés par une marque \triangle sont critiques pour la sécurité. Ne les remplacer que par une pièce portant le numéro spécifié.

6-1-8. CASSETTE COMPARTMENT ASSY, DRUM ASSY

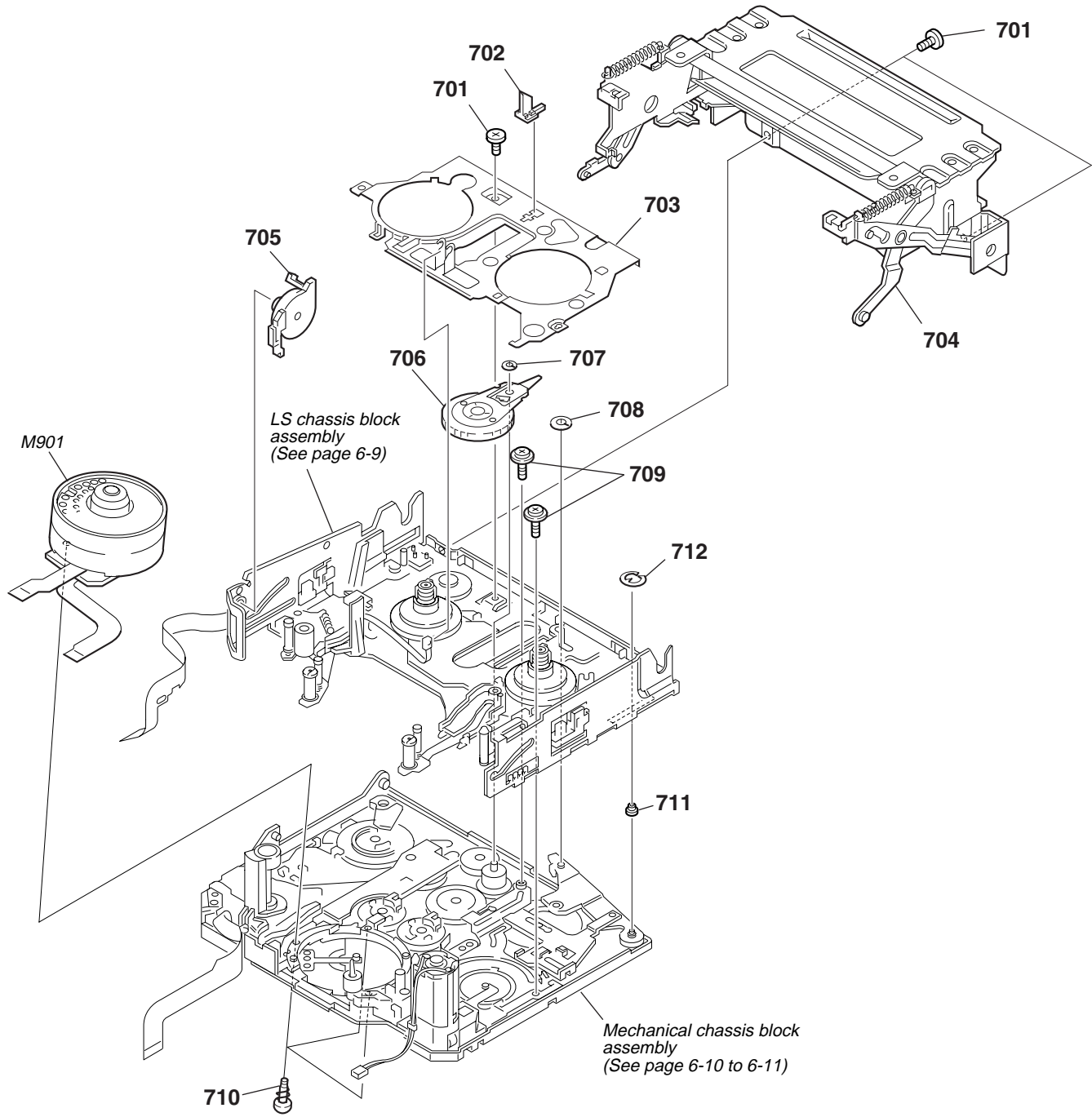

Ref. No.	Part No.	Description
701	3-065-932-01	PAN (2 MAIN M1.4X1.6), CAMERA
702	3-065-895-01	LEVER, REEL RELEASE
703	3-065-896-01	PLATE, BLIND
704	X-3951-298-1	CASSETTE COMPARTMENT ASSY
705	X-3951-302-1	DAMPER ASSY
706	X-3951-297-1	GEAR ASSY, R DRIVE
707	3-065-840-01	CUT (0.98X3X0.13), LUMILER (W)

Ref. No.	Part No.	Description
708	3-065-935-01	HLC CUT 1.8X4X0.5
709	3-947-503-01	SCREW (M1.4)
710	X-3951-299-1	SCREW ASSY, DRUM FITTING
711	3-074-309-01	ROLLER A, LS GUIDE
712	7-624-101-04	STOP RING 1.2 (E TYPE)
M901	A-7048-951-A	DRUM (DKH-04A-R) (SERVICE)

6-1-9. LS CHASSIS BLOCK ASSEMBLY

ns : not supplied

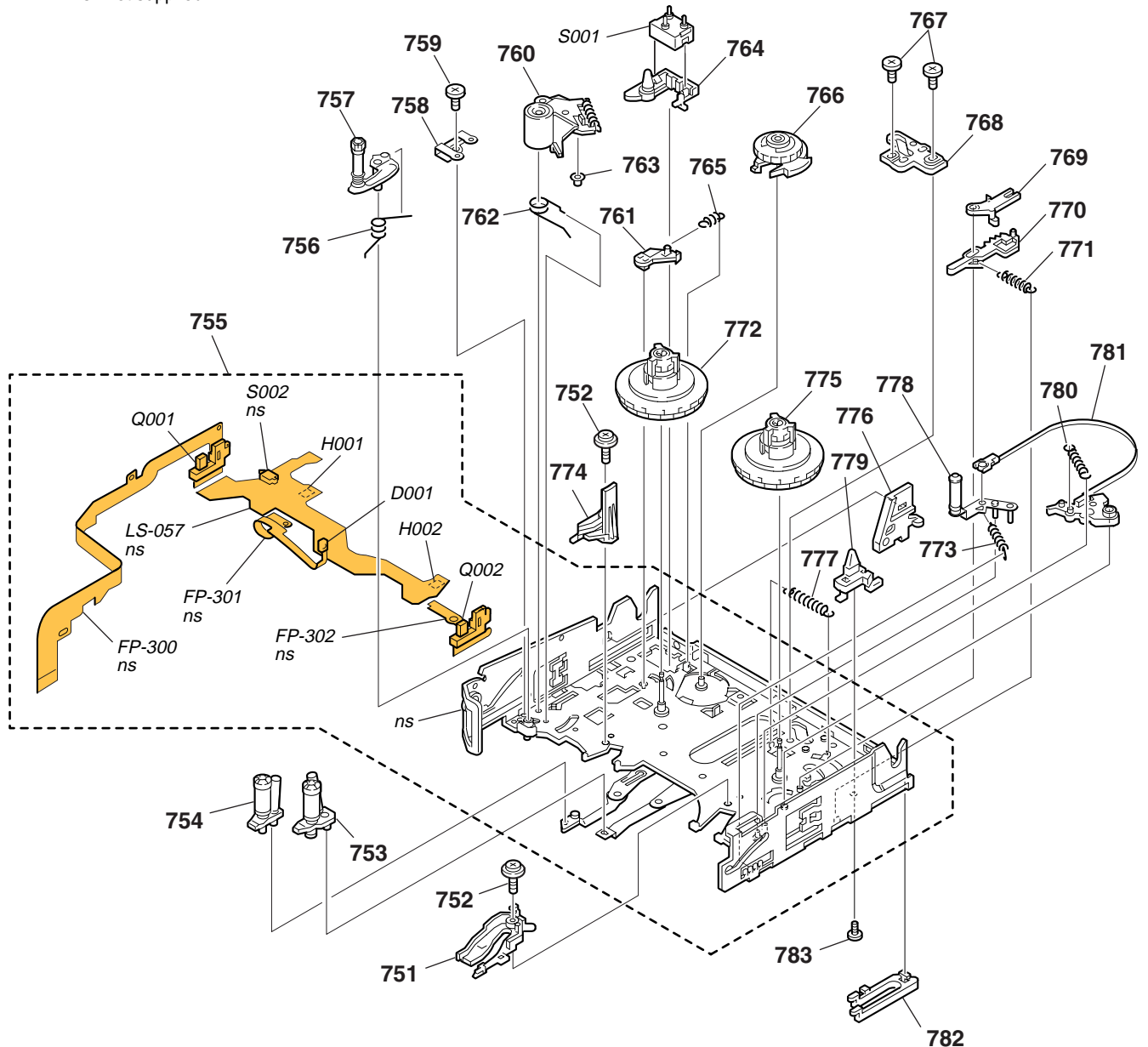

Ref. No.	Part No.	Description	Ref. No.	Part No.	Description
751	3-065-822-02	RAIL (S), GUIDE	771	3-065-830-01	SPRING, S RATCHET
752	3-947-503-01	SCREW (M1.4)	772	X-3951-288-1	TABLE (T) ASSY, REEL
753	A-7096-416-B	BASE (S) BLOCK ASSY, GUIDE	773	3-065-819-01	SPRING, TG1 ARM
754	A-7096-415-A	BASE (T) BLOCK ASSY, GUIDE	774	3-065-821-01	RAIL (T), GUIDE
755	A-7096-426-A	CHASSIS ASSY, LS	775	X-3951-289-1	TABLE (S) ASSY, REEL
756	3-065-802-01	SPRING, TG7 ARM	776	3-065-833-01	GUIDE, LOCK
757	A-7096-414-A	ARM BLOCK ASSY, TG7	777	3-065-831-01	PLATE (SPR), RE RETURN
758	3-065-801-01	RETAINER, TG7	778	X-3951-304-1	ARM ASSY, TG1
759	3-065-932-01	PAN (2 MAIN M1.4X1.6), CAMERA	779	3-065-835-01	GUIDE (S), CASSETTE
760	X-3951-303-1	ARM ASSY, PINCH	780	3-065-820-01	SPRING, RVS ARM
761	3-065-823-01	ARM, T RATCHET	781	X-3951-296-1	BAND (ASSY), BT
762	3-065-794-01	ROAD (SPR), PINCH ARM	782	3-065-836-01	COVER, LS GREASE
763	3-065-792-01	ROLLER, P LIM ARM	783	3-067-167-01	SCREW (M1.4X2), CAMERA TAPPING
764	3-065-834-01	GUIDE (T), CASSETTE	D001	8-719-988-42	DIODE GL453 (TAPE LED)
765	3-065-824-01	SPRING, T RATCHET	H001	8-719-033-37	ELEMENT, HALL HW-105C (T REEL)
766	A-7096-417-A	SOFT ASSY, T	H002	8-719-033-37	ELEMENT, HALL HW-105C (S REEL)
767	7-627-852-38	SCREW,PRECISION +P1.7X1.8TYPE3	Q001	8-729-907-25	PHOTO TRANSISTOR PT4850F (TAPE TOP)
768	3-065-832-01	PLATE, LS CAM	Q002	8-729-907-25	PHOTO TRANSISTOR PT4850F (TAPE END)
769	3-065-828-01	ARM, S RATCHET	S001	1-692-614-11	SWITCH, PUSH (3 KEY) (REC PROOF)
770	3-065-829-01	PLATE, S RATCHET (RE)			

6-1-10. MECHANICAL CHASSIS BLOCK ASSEMBLY-1

ns : not supplied

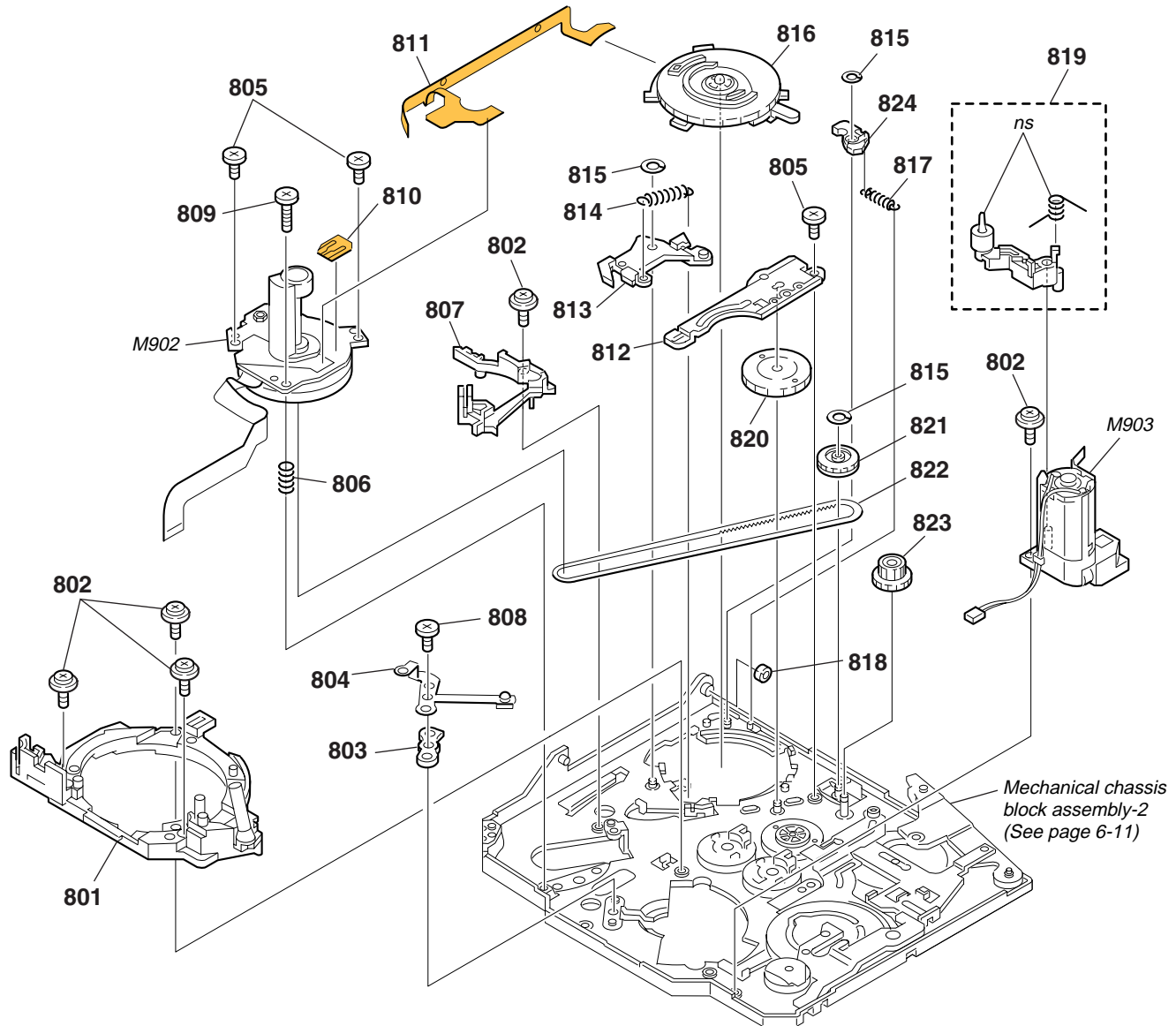

Ref. No.	Part No.	Description
801	A-7096-422-A	BASE ASSY, DRUM
802	3-947-503-01	SCREW (M1.4)
803	3-065-928-01	SPACER, GROUND
804	3-065-927-01	GROUND, DRUM
805	3-065-932-01	PAN (2 MAIN M1.4X1.6), CAMERA
806	3-067-154-01	SPRING, CAPSTAN
807	3-065-931-01	RAIL (T2), GUIDE
808	X-3947-398-1	SCREW ASSY, M1.7 PW
809	3-065-933-01	PAN (2 MAIN 1.4X4.5), CAMERA
810	1-677-049-11	FP-228 FLEXIBLE BOARD
811	1-680-434-11	FP-299 FLEXIBLE BOARD
812	3-065-877-01	PLATE (T), GUIDE LOCK
813	X-3951-301-1	PLATE ASSY, PINCH PRESSURE

Ref. No.	Part No.	Description
814	3-065-881-01	SPRING, P PRESSURE PLATE
815	3-065-934-01	HLW CUT 0.98X3X0.25
816	1-786-096-11	SWITCH, ROTARY
817	3-065-898-01	SPRING, EJECT ARM
818	3-065-870-01	ROLLER, LS GUIDE
819	A-7096-421-A	ARM ASSY, HCL
820	3-065-918-01	GEAR (2), CAM RELAY
821	A-7096-419-A	GEAR ASSY, CHANGE
822	3-065-902-01	BELT, TIMING
823	3-065-905-01	GEAR, RELAY
824	3-065-882-01	ARM, EJECT
M902	8-835-701-01	MOTOR, DC SCE13A/C-NP (CAPSTAN)
M903	A-7096-420-A	MOTOR ASSY, LD (LOADING)

6-1-11. MECHANICAL CHASSIS BLOCK ASSEMBLY-2

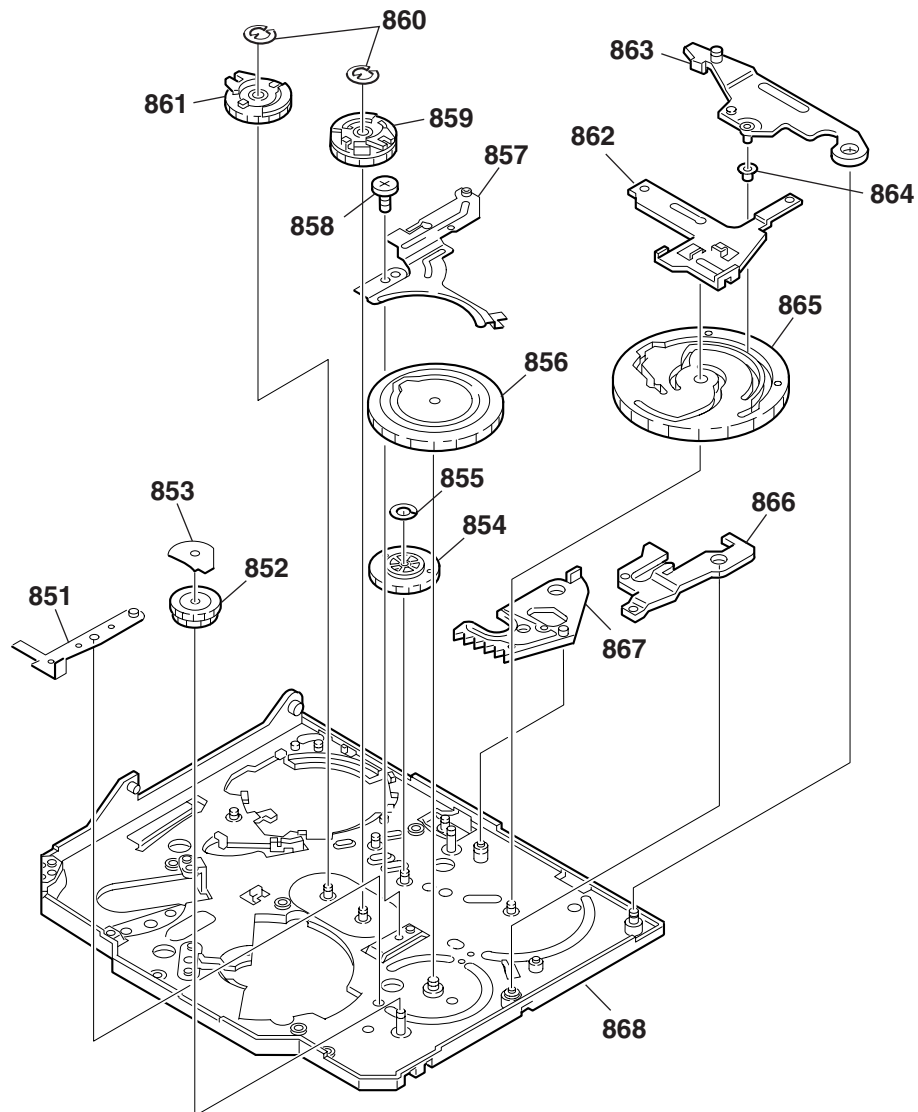

Ref. No.	Part No.	Description	Ref. No.	Part No.	Description
851	3-065-920-01	ARM, HC DRIVE	860	7-624-101-04	STOP RING 1.2 (E TYPE)
852	3-065-913-01	GEAR (4), LD	861	A-7096-412-A	GEAR (T) ASSY, GUIDE
853	3-065-914-01	SHEET, COVER	862	X-3951-307-1	PLATE ASSY, M SLIDE
854	3-065-917-01	GEAR (1), CAM RELAY	863	X-3951-305-1	ARM ASSY, LS
855	3-065-934-01	HLW CUT 0.98X3X0.25	864	3-065-901-01	ROLLER, LS ARM
856	3-065-915-01	GEAR (1), CAM	865	3-065-916-01	GEAR (2), CAM
857	3-065-878-01	PLATE (S), GUIDE LOCK	866	3-065-919-01	ARM, T1 LIMITTER
858	3-065-932-01	PAN (2 MAIN M1.4X1.6), CAMERA	867	X-3951-308-1	ARM ASSY, GL
859	A-7096-413-A	GEAR (S) ASSY, GUIDE	868	X-3951-300-2	CHASSIS ASSY, MECHANICAL

CD-358

LB-076

PD-156

6-2. ELECTRICAL PARTS LIST

NOTE:

- Due to standardization, replacements in the parts list may be different from the parts specified in the diagrams or the components used on the set.
- -XX, -X mean standardized parts, so they may have some difference from the original one.
- Items marked "*" are not stocked since they are seldom required for routine service. Some delay should be anticipated when ordering these items.
- CAPACITORS:
uF: μF
- COILS
uH: μH

- RESISTORS
All resistors are in ohms.
METAL: metal-film resistor
METAL OXIDE: Metal Oxide-film resistor
F: nonflammable
- SEMICONDUCTORS
In each case, u: μ, for example:
uA... : μA... , uPA... , μPA... ,
uPB... , μPB... , uPC... , μPC... ,
uPD... , μPD...
- Abbreviation
CND : Canadian model
KR : Korea model
JE : Tourist model
AUS : Australian model
HK : Hong Kong model

When indicating parts by reference number, please include the board name.

The components identified by mark Δ or dotted line with mark Δ are critical for safety. Replace only with part number specified.

Les composants identifiés par une marque Δ sont critiques pour la sécurité. Ne les remplacer que par une pièce portant le numéro spécifié.

CH : Chinese model
EE : East European model
NE : North European model
RU : Russian model
AR : Argentina model

Ref. No.	Part No.	Description
	A-7078-109-A	CD-358 BOARD, COMPLETE ***** (IC551 is not included in this complete board.) < CAPACITOR >
C551	1-164-004-11	CERAMIC CHIP 0.1uF 10% 25V
C553	1-107-826-11	CERAMIC CHIP 0.1uF 10% 16V
C554	1-125-777-11	CERAMIC CHIP 0.1uF 10% 10V
C556	1-125-777-11	CERAMIC CHIP 0.1uF 10% 10V
C557	1-125-777-11	CERAMIC CHIP 0.1uF 10% 10V
C559	1-125-777-11	CERAMIC CHIP 0.1uF 10% 10V
C561	1-113-992-11	TANTAL. CHIP 3.3uF 20% 35V
C562	1-104-851-11	TANTAL. CHIP 10uF 20% 10V
C563	1-107-826-11	CERAMIC CHIP 0.1uF 10% 16V
C564	1-107-826-11	CERAMIC CHIP 0.1uF 10% 16V
C565	1-135-259-11	TANTAL. CHIP 10uF 20% 6.3V
C567	1-107-826-11	CERAMIC CHIP 0.1uF 10% 16V
		< CONNECTOR >
CN551	1-779-336-11	CONNECTOR, FFC/FPC 24P
		< FERRITE BEAD >
FB551	1-414-445-11	FERRITE 0uH
		< IC >
IC551	A-7012-228-A	CCD BLOCK ASSY (CCD IMAGER)
IC552	6-701-755-01	IC AD80017AJRURL
		< COIL >
L551	1-469-528-91	INDUCTOR 100uH
L552	1-469-525-91	INDUCTOR 10uH
		< TRANSISTOR >
Q551	8-729-037-74	TRANSISTOR UN9213J-(TX).SO
		< RESISTOR >
R552	1-218-990-11	SHORT 0
R553	1-218-990-11	SHORT 0

Ref. No.	Part No.	Description
	A-7078-049-A	LB-076 BOARD, COMPLETE ***** < CAPACITOR >
C702	1-164-505-11	CERAMIC CHIP 2.2uF 16V
		< CONNECTOR >
CN701	1-779-334-11	CONNECTOR, FFC/FPC 20P
CN702	1-573-356-21	CONNECTOR, FFC/FPC 16P
		< DIODE >
D701	8-719-082-33	DIODE NSCW100-T38
D702	8-719-074-30	DIODE SML-310LTT86
		< IC >
IC701	8-759-581-11	IC NJM2125F(TE2)
		< TRANSISTOR >
Q701	8-759-054-48	TRANSISTOR UP04601008S0
Q702	8-729-054-45	TRANSISTOR UP04312008S0
		< RESISTOR >
R701	1-218-883-11	METAL CHIP 33K 0.5% 1/10W
R702	1-218-901-11	METAL CHIP 180K 0.5% 1/10W
R703	1-216-827-11	METAL CHIP 3.3K 5% 1/16W
R704	1-211-977-11	METAL CHIP 22 0.5% 1/10W
R706	1-216-839-11	METAL CHIP 33K 5% 1/16W
R707	1-218-867-11	RES-CHIP 6.8K 5% 1/10W
	A-7078-096-A	PD-156 (XC12)(SH) BOARD, COMPLETE (TRV738E/TRV740E:AEP,EE,NE,RU) *****
	A-7078-152-A	PD-156 (ZC12)(CA) BOARD, COMPLETE (TRV840) *****
		< CAPACITOR >
C5501	1-127-760-11	CERAMIC CHIP 4.7uF 10% 6.3V
C5504	1-164-943-11	CERAMIC CHIP 0.01uF 10% 16V
C5505	1-164-943-11	CERAMIC CHIP 0.01uF 10% 16V
C5506	1-164-943-11	CERAMIC CHIP 0.01uF 10% 16V
C5507	1-164-943-11	CERAMIC CHIP 0.01uF 10% 16V

Be sure to read "Precautions upon replacing CCD imager" on page 4-7 when changing the CCD imager.

Ref. No.	Part No.	Description	Ref. No.	Part No.	Description
C5509	1-110-457-11	ELECT CHIP 3.3uF 20% 25V	IC5602	8-759-075-70	IC TA75S393F-TE85R
C5510	1-164-943-11	CERAMIC CHIP 0.01uF 10% 16V	IC5701	8-759-573-02	IC BU9735K-E2
C5511	1-164-739-11	CERAMIC CHIP 560PF 5% 50V			< COIL >
C5512	1-125-777-11	CERAMIC CHIP 0.1uF 10% 10V			
C5513	1-164-943-11	CERAMIC CHIP 0.01uF 10% 16V			
C5514	1-135-259-11	TANTAL. CHIP 10uF 20% 6.3V	L5501	1-469-527-91	INDUCTOR 47uH
C5515	1-162-964-11	CERAMIC CHIP 0.001uF 10% 50V	L5502	1-469-525-91	INDUCTOR 10uH (TRV840)
C5516	1-164-870-11	CERAMIC CHIP 68PF 5% 50V	L5503	1-412-949-21	INDUCTOR 6.8uH
		(TRV738E/TRV740E:AEP,EE,NE,RU)			(TRV738E/TRV740E:AEP,EE,NE,RU)
C5516	1-164-872-11	CERAMIC CHIP 82PF 5% 50V	L5503	1-412-950-11	INDUCTOR 8.2uH (TRV840)
		(TRV840)	L5601	1-419-387-11	INDUCTOR 100uH
C5517	1-107-826-11	CERAMIC CHIP 0.1uF 10% 16V	L5602	1-412-056-11	INDUCTOR 4.7uH
C5518	1-107-826-11	CERAMIC CHIP 0.1uF 10% 16V			< TRANSISTOR >
C5519	1-107-826-11	CERAMIC CHIP 0.1uF 10% 16V	Q5502	8-729-041-23	TRANSISTOR MGSF1P02LT1
C5520	1-115-407-11	ELECT CHIP 10uF 20% 16V			(TRV738E/TRV740E:AEP,EE,NE,RU)
C5521	1-127-573-11	CERAMIC CHIP 1uF 10% 16V	Q5503	8-759-054-48	TRANSISTOR UP04601008S0
C5524	1-127-573-11	CERAMIC CHIP 1uF 10% 16V			(TRV738E/TRV740E:AEP,EE,NE,RU)
C5527	1-164-943-11	CERAMIC CHIP 0.01uF 10% 16V	Q5504	8-759-054-48	TRANSISTOR UP04601008S0
C5528	1-135-177-21	TANTALUM CHIP 1uF 20% 20V			(TRV738E/TRV740E:AEP,EE,NE,RU)
		(TRV738E/TRV740E:AEP,EE,NE,RU)	Q5505	8-729-052-64	TRANSISTOR DTC144EHT2L
C5530	1-164-943-11	CERAMIC CHIP 0.01uF 10% 16V			(TRV738E/TRV740E:AEP,EE,NE,RU)
		(TRV738E/TRV740E:AEP,EE,NE,RU)	Q5601	8-729-052-64	TRANSISTOR DTC144EHT2L
C5531	1-164-943-11	CERAMIC CHIP 0.01uF 10% 16V			(TRV738E/TRV740E:AEP,EE,NE,RU)
		(TRV738E/TRV740E:AEP,EE,NE,RU)	Q5604	6-550-065-01	TRANSISTOR CPH5504-TL-E
C5603	1-164-657-11	CERAMIC CHIP 0.015uF 10% 50V			< RESISTOR >
C5604	1-125-777-11	CERAMIC CHIP 0.1uF 10% 10V	R5501	1-218-985-11	RES-CHIP 470K 5% 1/16W
C5605	1-125-777-11	CERAMIC CHIP 0.1uF 10% 10V	R5503	1-208-933-11	METAL CHIP 82K 0.5% 1/16W
△ C5606	1-131-959-91	CERAMIC CHIP 12PF 10% 3KV	R5505	1-218-967-11	RES-CHIP 15K 5% 1/16W
C5607	1-115-566-11	CERAMIC CHIP 4.7uF 10% 10V	R5506	1-218-958-11	RES-CHIP 2.7K 5% 1/16W
C5701	1-125-777-11	CERAMIC CHIP 0.1uF 10% 10V	R5507	1-218-973-11	RES-CHIP 47K 5% 1/16W
		< CONNECTOR >	R5508	1-218-975-11	RES-CHIP 68K 5% 1/16W
CN5501	1-815-031-11	CONNECTOR, FFC/FPC (ZIF) 24P	R5509	1-218-969-11	RES-CHIP 22K 5% 1/16W
* CN5502	1-573-984-11	CONNECTOR, BOARD TO BOARD 10P	R5510	1-218-975-11	RES-CHIP 68K 5% 1/16W
CN5601	1-764-709-11	CONNECTOR, FFC/FPC 10P	R5511	1-218-989-11	RES-CHIP 1M 5% 1/16W
CN5701	1-794-998-31	PIN, CONNECTOR 20P	R5512	1-218-977-11	RES-CHIP 100K 5% 1/16W
CN5702	1-816-176-11	CONNECTOR, FFC/FPC (ZIF) 6P	R5513	1-218-989-11	RES-CHIP 1M 5% 1/16W
CN5703	1-816-178-11	CONNECTOR, FFC/FPC (ZIF) 20P			(TRV738E/TRV740E:AEP,EE,NE,RU)
CN5704	1-778-508-21	PIN, CONNECTOR (PC BOARD) 6P	R5514	1-218-990-11	SHORT 0 (TRV840)
CN5705	1-766-759-11	CONNECTOR, FFC/FPC 4P	R5515	1-218-990-11	SHORT 0
		< DIODE >			(TRV738E/TRV740E:AEP,EE,NE,RU)
D5502	8-719-084-47	DIODE 1SV290(TPL3)	R5516	1-218-962-11	RES-CHIP 5.6K 5% 1/16W
D5503	8-719-988-61	DIODE 1SS355TE-17			(TRV738E/TRV740E:AEP,EE,NE,RU)
		(TRV738E/TRV740E:AEP,EE,NE,RU)	R5516	1-218-965-11	RES-CHIP 10K 5% 1/16W
D5601	8-719-988-61	DIODE 1SS355TE-17			(TRV840)
		< FERRITE BEAD >	R5517	1-218-978-11	RES-CHIP 120K 5% 1/16W
FB5501	1-414-760-21	FERRITE 0uH			(TRV840)
FB5502	1-414-760-21	FERRITE 0uH	R5518	1-218-990-11	SHORT 0 (TRV840)
FB5503	1-414-760-21	FERRITE 0uH	R5519	1-218-990-11	SHORT 0
		(TRV738E/TRV740E:AEP,EE,NE,RU)			(TRV738E/TRV740E:AEP,EE,NE,RU)
		< IC >	R5520	1-218-990-11	SHORT 0 (TRV840)
IC5501	8-752-102-40	IC CXA3592R-T4	R5521	1-218-973-11	RES-CHIP 47K 5% 1/16W
		(TRV738E/TRV740E:AEP,EE,NE,RU)	R5522	1-218-963-11	RES-CHIP 6.8K 5% 1/16W
IC5501	8-759-660-92	IC RB5P003AM1 (TRV840)			(TRV840)
IC5502	8-759-714-77	IC LZ9FF474	R5522	1-218-957-11	RES-CHIP 2.2K 5% 1/16W
		(TRV738E/TRV740E:AEP,EE,NE,RU)			(TRV738E/TRV740E:AEP,EE,NE,RU)
IC5502	8-759-833-18	IC CM7021L3-E2 (TRV840)	R5523	1-218-990-11	SHORT 0
IC5601	8-759-564-49	IC TC7W53FU(TE12R)	R5525	1-218-990-11	SHORT 0 (TRV840)
			R5528	1-218-990-11	SHORT 0 (TRV840)

Note :

The components identified by mark △ or dotted line with mark △ are critical for safety. Replace only with part number specified.

Note :

Les composants identifiés par une marque △ sont critiques pour la sécurité. Ne les remplacer que par une pièce portant le numéro spécifié.

DCR-TRV738E/TRV740/TRV740E/TRV840

PD-156

PD-160

Ref. No.	Part No.	Description
R5529	1-218-990-11	SHORT 0 (TRV840)
R5530	1-218-990-11	SHORT 0 (TRV840)
R5531	1-218-980-11	RES-CHIP 180K 5% 1/16W (TRV738E/TRV740E:AEP,EE,NE,RU)
R5532	1-218-977-11	RES-CHIP 100K 5% 1/16W (TRV738E/TRV740E:AEP,EE,NE,RU)
R5533	1-218-989-11	RES-CHIP 1M 5% 1/16W (TRV738E/TRV740E:AEP,EE,NE,RU)
R5534	1-218-990-11	SHORT 0
R5540	1-218-977-11	RES-CHIP 100K 5% 1/16W (TRV738E/TRV740E:AEP,EE,NE,RU)
R5541	1-218-977-11	RES-CHIP 100K 5% 1/16W (TRV738E/TRV740E:AEP,EE,NE,RU)
R5601	1-216-055-00	METAL CHIP 1.8K 5% 1/10W
R5602	1-218-977-11	RES-CHIP 100K 5% 1/16W
R5603	1-218-966-11	RES-CHIP 12K 5% 1/16W
R5606	1-218-969-11	RES-CHIP 22K 5% 1/16W
R5607	1-218-949-11	RES-CHIP 470 5% 1/16W
R5612	1-218-965-11	RES-CHIP 10K 5% 1/16W
R5613	1-218-965-11	RES-CHIP 10K 5% 1/16W (TRV738E/TRV740E:AEP,EE,NE,RU)
R5613	1-218-968-11	RES-CHIP 18K 5% 1/16W (TRV840)
R5704	1-218-987-11	RES-CHIP 680K 5% 1/16W
< COMPOSITION CIRCUIT BLOCK >		
RB5501	1-234-372-21	RES, NETWORK 100X4 (1005)
RB5502	1-234-384-11	RES, NETWORK 1MX4 (1005) (TRV738E/TRV740E:AEP,EE,NE,RU)
RB5503	1-234-378-21	RES, NETWORK 10KX4 (1005) (TRV738E/TRV740E:AEP,EE,NE,RU)
< TRANSFORMER >		
△ T5601	1-435-785-11	TRANSFORMER, INVERTER (TRV840)
△ T5601	1-435-227-11	TRANSFORMER, INVERTER (TRV738E/TRV740E:AEP,EE,NE,RU)
A-7078-052-A	PD-160 (X6)(SO) BOARD, COMPLETE (TRV740/TRV740E:E,HK,AUS,CH,JE)	*****
A-7078-145-A	PD-160 (ZS12)(SO) BOARD, COMPLETE (TRV840)	*****
< CAPACITOR >		
C5501	1-127-760-11	CERAMIC CHIP 4.7uF 10% 6.3V
C5504	1-164-943-11	CERAMIC CHIP 0.01uF 10% 16V
C5505	1-164-943-11	CERAMIC CHIP 0.01uF 10% 16V
C5506	1-164-943-11	CERAMIC CHIP 0.01uF 10% 16V
C5507	1-164-943-11	CERAMIC CHIP 0.01uF 10% 16V
C5509	1-110-457-11	ELECT CHIP 3.3uF 20% 25V
C5510	1-164-943-11	CERAMIC CHIP 0.01uF 10% 16V
C5511	1-164-739-11	CERAMIC CHIP 560PF 5% 50V
C5512	1-125-777-11	CERAMIC CHIP 0.1uF 10% 10V
C5515	1-162-964-11	CERAMIC CHIP 0.001uF 10% 50V

Ref. No.	Part No.	Description
C5516	1-164-872-11	CERAMIC CHIP 82PF 5% 50V (TRV740/TRV740E:E,HK,AUS,CH,JE)
C5516	1-164-874-11	CERAMIC CHIP 100PF 5% 50V (TRV840)
C5517	1-109-982-11	CERAMIC CHIP 1uF 10% 10V
C5518	1-109-982-11	CERAMIC CHIP 1uF 10% 10V
C5519	1-109-982-11	CERAMIC CHIP 1uF 10% 10V
C5532	1-109-982-11	CERAMIC CHIP 1uF 10% 10V
C5533	1-115-566-11	CERAMIC CHIP 4.7uF 10% 10V
C5534	1-109-982-11	CERAMIC CHIP 1uF 10% 10V
C5536	1-125-777-11	CERAMIC CHIP 0.1uF 10% 10V
C5538	1-164-943-11	CERAMIC CHIP 0.01uF 10% 16V
C5540	1-107-826-11	CERAMIC CHIP 0.1uF 10% 16V
C5602	1-115-566-11	CERAMIC CHIP 4.7uF 10% 10V
C5604	1-164-657-11	CERAMIC CHIP 0.015uF 10% 50V
C5605	1-125-777-11	CERAMIC CHIP 0.1uF 10% 10V
C5606	1-125-777-11	CERAMIC CHIP 0.1uF 10% 10V
△ C5607	1-131-959-91	CERAMIC CHIP 12PF 10% 3KV
C5701	1-125-777-11	CERAMIC CHIP 0.1uF 10% 10V
< CONNECTOR >		
CN5501	1-815-031-11	CONNECTOR, FFC/FPC (ZIF) 24P
* CN5502	1-573-984-11	CONNECTOR, BOARD TO BOARD 10P
CN5601	1-764-709-11	CONNECTOR, FFC/FPC 10P
CN5701	1-794-998-31	PIN, CONNECTOR 20P
CN5702	1-816-176-11	CONNECTOR, FFC/FPC (ZIF) 6P
CN5703	1-816-178-11	CONNECTOR, FFC/FPC (ZIF) 20P
CN5704	1-778-508-21	PIN, CONNECTOR (PC BOARD) 6P
CN5705	1-766-759-11	CONNECTOR, FFC/FPC 4P
< DIODE >		
D5502	8-719-084-47	DIODE 1SV290(TPL3)
D5503	8-719-050-42	DIODE RD3.3UM-T1B
D5601	8-719-988-61	DIODE 1SS355TE-17
< FERRITE BEAD >		
FB5502	1-414-760-21	FERRITE 0uH
FB5504	1-414-760-21	FERRITE 0uH
< IC >		
IC5501	8-752-100-95	IC CXA3289AR-T4
IC5502	8-752-407-33	IC CXD3512R-T4 (TRV740/TRV740E:E,HK,AUS,CH,JE)
IC5502	8-752-409-15	IC CXD3516R-T4 (TRV840)
IC5601	8-759-564-49	IC TC7W53FU(TE12R)
IC5602	8-759-075-70	IC TA75S393F-TE85R
IC5701	8-759-573-02	IC BU9735K-E2
< COIL >		
L5501	1-469-527-91	INDUCTOR 47uH
L5505	1-412-949-21	INDUCTOR 6.8uH (TRV840)
L5505	1-412-956-21	INDUCTOR 27uH (TRV740/TRV740E:E,HK,AUS,CH,JE)
L5601	1-419-387-21	INDUCTOR 100uH
L5602	1-412-056-11	INDUCTOR 4.7uH

<p>Note : The components identified by mark △ or dotted line with mark △ are critical for safety. Replace only with part number specified.</p>	<p>Note : Les composants identifiés par une marque △ sont critiques pour la sécurité. Ne les remplacer que par une pièce portant le numéro spécifié.</p>
-----------------------------------------------------------------------------------------------------------------------------------------------------------	---------------------------------------------------------------------------------------------------------------------------------------------------------------------

Ref. No.	Part No.	Description
		< TRANSISTOR >
Q5503	8-759-054-48	TRANSISTOR UP04601008S0
Q5504	8-729-052-65	TRANSISTOR 2SA1774HT2L
Q5505	8-729-041-23	TRANSISTOR NDS356AP
Q5506	8-729-052-64	TRANSISTOR DTC144EHT2L
Q5508	8-759-054-48	TRANSISTOR UP04601008S0
Q5601	8-729-052-64	TRANSISTOR DTC144EHT2L
Q5602	6-550-083-01	TRANSISTOR TPC6C01(TE85R) (TRV740/TRV740E:E,HK,AUS,CH,JE)
Q5604	6-550-065-01	TRANSISTOR CPH5504-TL-E
		< RESISTOR >
R5501	1-218-985-11	RES-CHIP 470K 5% 1/16W
R5503	1-208-933-11	METAL CHIP 82K 0.5% 1/16W (TRV840)
R5503	1-208-935-11	METAL CHIP 100K 0.5% 1/16W (TRV740/TRV740E:E,HK,AUS,CH,JE)
R5506	1-218-958-11	RES-CHIP 2.7K 5% 1/16W
R5507	1-218-973-11	RES-CHIP 47K 5% 1/16W
R5508	1-218-975-11	RES-CHIP 68K 5% 1/16W
R5509	1-218-969-11	RES-CHIP 22K 5% 1/16W
R5510	1-218-975-11	RES-CHIP 68K 5% 1/16W
R5511	1-218-989-11	RES-CHIP 1M 5% 1/16W
R5512	1-218-977-11	RES-CHIP 100K 5% 1/16W
R5522	1-218-969-11	RES-CHIP 22K 5% 1/16W (TRV740/TRV740E:E,HK,AUS,CH,JE)
R5522	1-218-973-11	RES-CHIP 47K 5% 1/16W (TRV840)
R5551	1-218-973-11	RES-CHIP 47K 5% 1/16W
R5572	1-218-965-11	RES-CHIP 10K 5% 1/16W
R5573	1-218-965-11	RES-CHIP 10K 5% 1/16W
R5574	1-208-957-11	RES-CHIP 820K 5% 1/16W
R5575	1-218-975-11	RES-CHIP 68K 5% 1/16W
R5576	1-218-989-11	RES-CHIP 1M 5% 1/16W
R5577	1-218-985-11	RES-CHIP 470K 5% 1/16W
R5579	1-218-979-11	RES-CHIP 150K 5% 1/16W
R5590	1-218-990-11	SHORT 0
R5609	1-218-965-11	RES-CHIP 10K 5% 1/16W
R5610	1-216-055-00	METAL CHIP 1.8K 5% 1/10W
R5611	1-218-980-11	RES-CHIP 180K 5% 1/16W
R5612	1-218-969-11	RES-CHIP 22K 5% 1/16W
R5614	1-218-965-11	RES-CHIP 10K 5% 1/16W (TRV740/TRV740E:E,HK,AUS,CH,JE)
R5614	1-218-968-11	RES-CHIP 18K 5% 1/16W (TRV840)
R5617	1-218-969-11	RES-CHIP 22K 5% 1/16W
R5618	1-218-949-11	RES-CHIP 470 5% 1/16W
R5704	1-218-987-11	RES-CHIP 680K 5% 1/16W
		< COMPOSITION CIRCUIT BLOCK >
RB5501	1-234-372-21	RES, NETWORK 100X4 (1005)
		< TRANSFORMER >
△ T5601	1-435-227-11	TRANSFORMER, INVERTER (TRV740/TRV740E:E,HK,AUS,CH,JE)
△ T5601	1-435-785-11	TRANSFORMER, INVERTER (TRV840)

Ref. No.	Part No.	Description
	A-7078-047-A	SI-032 BOARD, COMPLETE *****
		< CAPACITOR >
C305	1-107-826-11	CERAMIC CHIP 0.1uF 10% 16V
C310	1-107-826-11	CERAMIC CHIP 0.1uF 10% 16V
C311	1-104-847-11	TANTAL. CHIP 22uF 20% 4V
C312	1-104-847-11	TANTAL. CHIP 22uF 20% 4V
C314	1-162-969-11	CERAMIC CHIP 0.0068uF 10% 25V
C315	1-162-969-11	CERAMIC CHIP 0.0068uF 10% 25V
		< CONNECTOR >
CN301	1-764-526-11	CONNECTOR, FFC/FPC 18P
CN302	1-816-232-11	PIN, CONNECTOR (PC BOARD) 4P
CN304	1-779-339-21	CONNECTOR, FFC/FPC 30P
		< DIODE >
D301	8-719-067-44	DIODE CL-310IRS-X-TU
D302	8-719-067-44	DIODE CL-310IRS-X-TU
D303	8-719-062-16	DIODE 01ZA8.2(TPL3)
D304	8-719-056-85	DIODE UJZSTE-178.2B
D306	8-719-074-30	DIODE SML-310LTT86
D309	8-719-062-16	DIODE 01ZA8.2(TPL3)
D313	8-719-062-16	DIODE 01ZA8.2(TPL3)
		< FERRITE BEAD >
FB301	1-414-760-21	FERRITE 0uH
FB302	1-414-760-21	FERRITE 0uH
		< IC >
IC301	6-701-681-01	IC NJL61H400A
		< TRANSISTOR >
Q301	8-729-141-73	TRANSISTOR 2SD1938(F)-S(TX).SO
		< RESISTOR >
R301	1-216-810-11	METAL CHIP 120 5% 1/16W
R307	1-216-864-11	METAL CHIP 0 5% 1/16W
R316	1-216-817-11	METAL CHIP 470 5% 1/16W
R319	1-216-019-00	METAL CHIP 56 5% 1/10W
R320	1-216-019-00	METAL CHIP 56 5% 1/10W
		< SENSOR >
SE301	1-803-042-31	SENSOR, ANGULAR VELOCITY (PITCH) (SERVICE)
SE302	1-803-042-41	SENSOR, ANGULAR VELOCITY (YAW) (SERVICE)
		< VARISTOR >
VDR301	1-801-923-11	VARISTOR, CHIP
VDR302	1-801-923-11	VARISTOR, CHIP
VDR303	1-801-923-11	VARISTOR, CHIP

Note :

The components identified by mark △ or dotted line with mark △ are critical for safety. Replace only with part number specified.

Note :

Les composants identifiés par une marque △ sont critiques pour la sécurité. Ne les remplacer que par une pièce portant le numéro spécifié.

DCR-TRV738E/TRV740/TRV740E/TRV840

VC-278

Ref. No.	Part No.	Description
A-7012-212-A	VC-278 (GNA)	BOARD, COMPLETE (SERVICE) (TRV740/TRV840) *****
A-7012-362-A	VC-278 (GPAO)	BOARD, COMPLETE (SERVICE) (TRV738E) *****
A-7012-363-A	VC-278 (GPA)	BOARD, COMPLETE (SERVICE) (TRV740E) *****

Ref. No. Part No. Description

**Electrical parts list of the VC-278 board are not shown.
Pages from 6-17 to 6-25 are not shown.**



Ref. No. Part No. Description

ACCESSORIES

	1-475-141-61	REMOTE COMMANDER (RMT-814)
△	1-475-599-11	ADAPTOR, AC (AC-L10) (TRV738E/TRV740:US,CND,E,JE/ TRV740E:AEP,EE,NE,RU,E,HK,AUS,JE/TRV840)
△	1-475-599-71	ADAPTOR, AC (AC-L10) (TRV740:KR)
△	1-475-599-81	ADAPTOR, AC (AC-L10) (TRV740E:CH)
△	1-569-007-11	ADAPTOR, CONVERSION 2P (TRV740:JE/TRV740E:JE)
△	1-569-008-21	ADAPTOR, CONVERSION 2P (TRV740:E/TRV740E:E,HK/TRV840:E)
	1-573-291-11	CONNECTOR, CONVERSION 21P (TRV738E/TRV740E:AEP,EE,NE,RU)
△	1-696-819-11	CORD, POWER (TRV740E:AUS)
	1-757-293-21	CORD, CONNECTION (USB 5P)
	1-765-080-11	CORD, CONNECTION (AV CABLE) (1.5m)

Note :

The components identified by mark △ or dotted line with mark △ are critical for safety. Replace only with part number specified.

Note :

Les composants identifiés par une marque △ sont critiques pour la sécurité. Ne les remplacer que par une pièce portant le numéro spécifié.

<u>Ref. No.</u>	<u>Part No.</u>	<u>Description</u>
△	1-769-608-11	CORD, POWER (TRV738E/TRV740:E/TRV740E:AEP,EE,NE,RU,E/TRV840:E,AR)
△	1-776-985-11	CORD, POWER (TRV740:KR)
△	1-782-476-11	CORD, POWER (TRV740E:CH)
△	1-783-374-11	CORD, POWER (TRV740E:HK)
△	1-790-107-22	CORD, POWER (TRV740:US,CND/TRV840:US,CND)
△	1-790-732-11	CORD, POWER (TRV740:JE/TRV740E:JE)
	3-072-414-01	SPVD-008 (CD-ROM USB DRIVER) (TRV738E/TRV740:E,JE,KR/TRV740E/TRV840:E,AR)
	3-072-650-11	MANUAL, INSTRUCTION (ENGLISH) (TRV740:US,CND,E,JE/TRV840)
	3-072-650-21	MANUAL, INSTRUCTION (FRENCH) (TRV740:CND/TRV840:CND)
	3-072-650-31	MANUAL, INSTRUCTION (SPANISH/PORTUGUESE) (TRV740:E,JE/TRV840:E,AR)
	3-072-650-41	MANUAL, INSTRUCTION (TRADITIONAL CHINESE) (TRV740:E)
	3-072-650-51	MANUAL, INSTRUCTION (SIMPLIFIED CHINESE) (TRV740:E)
	3-072-650-61	MANUAL, INSTRUCTION (KOREAN) (TRV740:JE,KR)
	3-072-651-11	MANUAL, INSTRUCTION (ENGLISH/RUSSIAN) (TRV740E:RU,E,HK,AUS,CH,JE)
	3-072-651-21	MANUAL, INSTRUCTION (FRENCH/GERMAN) (TRV740E:AEP,E,JE)
	3-072-651-31	MANUAL, INSTRUCTION (ARABIC/PERSIAN) (TRV740E:E)
	3-072-651-41	MANUAL, INSTRUCTION (TRADITIONAL CHINESE) (TRV740E:HK)
	3-072-651-51	MANUAL, INSTRUCTION (SIMPLIFIED CHINESE) (TRV740E:E,CH,JE)
	3-072-651-61	MANUAL, INSTRUCTION (ENGLISH DUTCH) (TRV740E:AEP)
	3-072-651-71	MANUAL, INSTRUCTION (SPANISH/PORTUGUESE) (TRV740E:AEP)
	3-072-651-81	MANUAL, INSTRUCTION (ITALIAN/GREEK) (TRV740E:AEP)
	3-072-651-91	MANUAL, INSTRUCTION (ENGLISH/SWEDISH) (TRV740E:NE)
	3-072-652-11	MANUAL, INSTRUCTION (DANISH/FINNISH) (TRV740E:NE)
	3-072-652-21	MANUAL, INSTRUCTION (POLISH/CZECH) (TRV740E:EE)
	3-072-652-31	MANUAL, INSTRUCTION (HUNGARIAN/SLOVAKIAN) (TRV740E:EE)
	3-072-653-21	MANUAL, INSTRUCTION (FRENCH/GERMAN) (TRV738E:AEP)
	3-072-653-31	MANUAL, INSTRUCTION (ENGLISH DUTCH) (TRV738E:AEP)
	3-072-653-41	MANUAL, INSTRUCTION (SPANISH/PORTUGUESE) (TRV738E:AEP)
	3-072-653-51	MANUAL, INSTRUCTION (ITALIAN/GREEK) (TRV738E:AEP)
	3-072-654-01	SPVD-008 (I) (TRV740:US,CND/TRV840:US,CND)
	3-742-854-01	LID, BATTERY CASE (FOR RMT-814)
	3-987-015-01	BELT (S), SHOULDER
	X-3949-376-1	CAP (N) ASSY, LENS NP-FM50 BATTERY PACK (NOT SUPPLIED)

Note :

The components identified by mark △ or dotted line with mark △ are critical for safety. Replace only with part number specified.

Note :

Les composants identifiés par une marque △ sont critiques pour la sécurité. Ne les remplacer que par une pièce portant le numéro spécifié.

〈FOR CAMERA COLOR REPRODUCTION ADJUSTMENT〉

For NTSC model

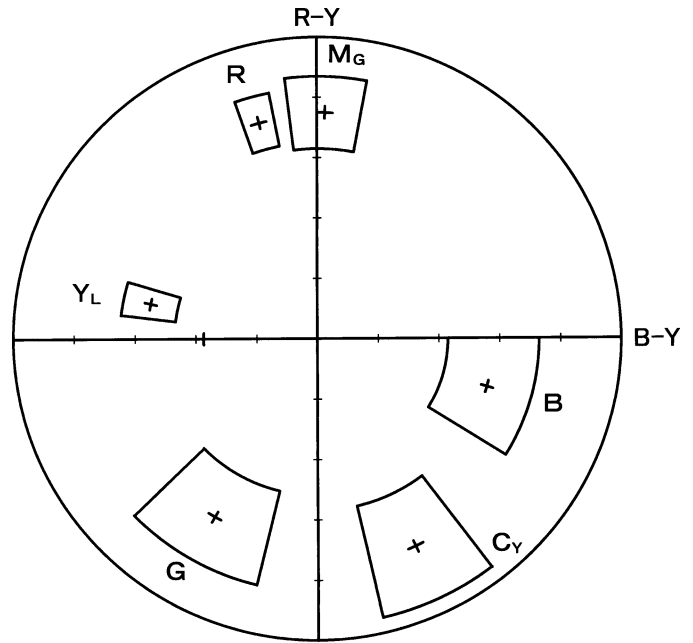

DCR-TRV740/TRV840

Take a copy of CAMERA COLOR REPRODUCTION FRAME with a clear sheet for use.



For PAL model

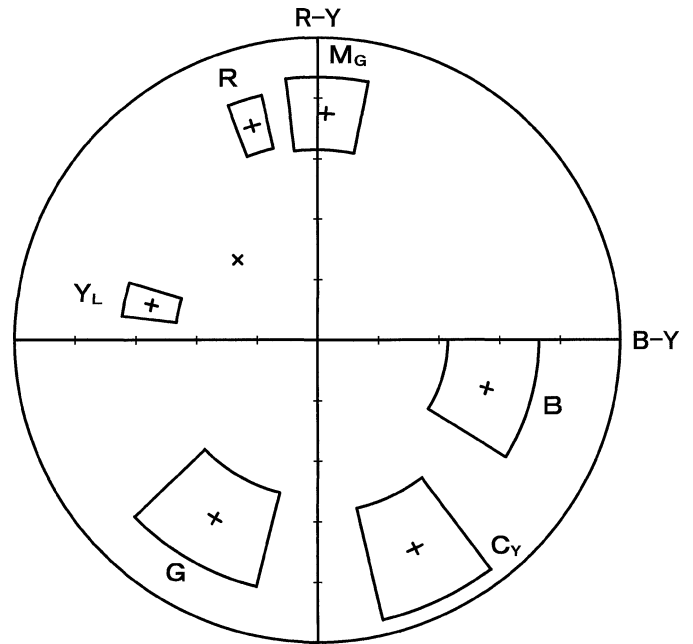

DCR-TRV738E/TRV740E



Revision History

Ver.	Date	History	Contents	S.M. Rev. issued
1.0	2002.03	Official Release	—	—